

collections

Catalogo Generale

2019

General Catalogue
Catalogue Général
Gesamtkatalog
Общий Каталог

A

202	alpi
228	alpi grip 2CM
10	artica
16	artica roc
230	artica roc 2CM

B

88	block
92	borgate fiorentine
20	boulevard
94	brera

C

172	cave+ TILE+ <small>PREMIUM SLABS</small>
190	cave
196	cave roc
100	concreta
26	cosmos
104	cottoantico
108	cottocemento
198	cremo

D

32	district
38	district roc

E

40	eternity
----	----------

F

116	ferrocemento+ TILE+ <small>PREMIUM SLABS</small>
116	ferrocemento

G

44	galapagos
128	global+ TILE+ <small>PREMIUM SLABS</small>
128	global

H

220	home5+ apuano 5mm
222	home5+ linfa 5mm
224	home5+ material 5mm

K

46	kaleido
60	kaleido roc

L

138	laredo
140	logica
64	luserna
68	luserna roc

M

208	majestic
144	metropolitan
72	morestone

N

210	natif light
148	neutra
232	neutra roc 2CM

P

214	painted
76	phoenix

S

156	salento
-----	---------

U

160	urbandeck
234	urbandeck grip 2CM

V

166	valencia
80	volcano

Look index

INDICE PER ASPETTO - INDEX PAR ASPECT - VERZEICHNIS NACH OPTIK - УКАЗАТЕЛЬ DESIGN

stone effect

EFFETTO PIETRA / IMITATION PIERRE
STEINEFFEKT / КАМЕНЬ

10	artica
16	artica roc
20	boulevard
26	cosmos
32	district
38	district roc
40	eternity
44	galapagos
46	kaleido
60	kaleido roc
64	luserna
68	luserna roc
72	morestone
76	phoenix
80	volcano

concrete/ terracotta effect

EFFETTO CEMENTO/COTTO IMITATION
CIMENTS/COTTO / COTTO UND
BETON-OPTIK / ЦЕМЕНТ И КОТТО

88	block
92	borgate fiorentine
94	brera
100	concreta
104	cottoantico
108	cottocemento
116	ferrocemento+ <small>TILE+ PREMIUM ISLANDS</small>
116	ferrocemento
128	global+ <small>TILE+ PREMIUM ISLANDS</small>
128	global
138	laredo
140	logica
144	metropolitan
148	neutra
156	salento
160	urbandeck
166	valencia

marble effect

EFFETTO MARMO / IMITATION MARBRE
MARMOR-OPTIK / МРАМОР

172	cave+ <small>TILE+ PREMIUM ISLANDS</small>
190	cave
196	cave roc
198	cremo

wood effect

EFFETTO LEGNO / IMITATION BOI
HOLZ-OPTIK / ДЕРЕВО

202	alpi
208	majestic
210	natif light
214	painted

5mm collection

220	home5+ apuano 5mm
222	home5+ linfa 5mm
224	home5+ material 5mm

2CM outdoor
paving
20 mm

228	alpi grip
230	artica roc
232	neutra roc
234	urbandeck grip

sezione tecnica

TECHNICAL SECTION / SECTION
TECHNIQUE / TECHNISCHER ABSHNITT
КТЕХНИЧЕСКИЙ РАЗДЕЛ

236

Outdoor paving index

INDICE GRIP - INDEX GRIP - VERZEICHNIS AUSSENBEREICH - УКАЗАТЕЛЬ «GRIP»

202	alpi grip
228	alpi grip 2CM - 20mm
16	artica roc
230	artica roc 2CM - 20mm
94	brera grip
196	cave roc
100	concreta corindonato
26	cosmos naturale
26	cosmos grip
104	cottoantico grip
108	cottocemento grip
38	district roc
116	ferrocemento grip
44	galapagos grip
128	global grip
60	kaleido roc
138	laredo grip
68	luserna roc
72	morestone grip
210	natif light grip
148	neutra grip
232	neutra roc 2CM - 20mm
214	painted grip
76	phoenix grip
160	urbandeck roc
234	urbandeck grip 2CM - 20mm
166	valencia corindonato

Indice per formato

INDEX BY FORMAT - INDEX SELON LE FORMAT - VERZEICHNIS NACH FORMAT - ИНДЕКС ПО ФОРМАТУ

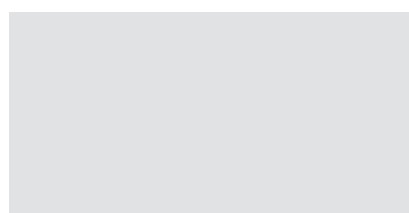

160x320

- 172 cave+
- 116 ferroemento+

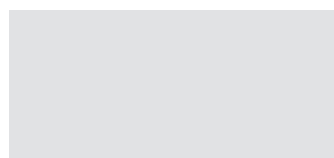

120x260 / 117,5x258,5

- 172 cave+
- 116 ferroemento+
- 128 global+

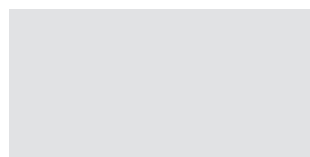

120x241 / 117,5x235

- 172 cave+
- 116 ferroemento+
- 128 global+

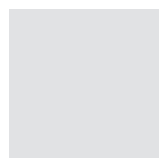

120x120 / 117,5x117,5

- 172 cave+
- 116 ferroemento+
- 128 global+
- 160 urbandeck

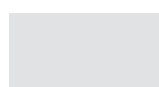

60x120 / 59x117,5

- 202 alpi
- 20 boulevard
- 190 cave
- 172 cave+
- 32 district
- 116 ferroemento
- 116 ferroemento+
- 128 global+
- 46 kaleido
- 72 morestone
- 148 neutra
- 160 urbandeck

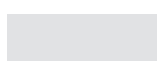

40x120

- 228 alpi grip 2cm
- 234 urbandeck grip 2cm

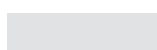

30x120 / 29,5x117,5

- 202 alpi
- 20 boulevard
- 190 cave
- 32 district
- 116 ferroemento

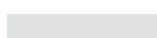

20x120

- 202 alpi
- 222 home5+ linfa 5mm

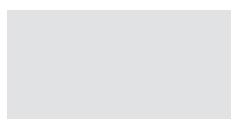

90,2x180,7 / 88x176

- 94 brera
- 190 cave

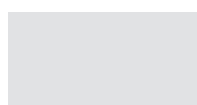

75,5x151,2

- 108 cottocemento

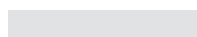

25x151,2

- 202 alpi



90,2x90,2 / 88x88

- 94 brera
- 190 cave

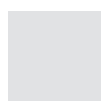

75,5x75,5

- 108 cottocemento
- 208 majestic
- 72 morestone

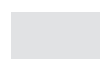

37,5x75,5

- 108 cottocemento



60x60 / 60,5x60,5 59,5x59,5 / 59x59

- 10 artica
- 16 artica roc
- 230 artica roc 2cm
- 88 block
- 20 boulevard
- 94 brera
- 190 cave
- 196 cave roc
- 100 concreta
- 108 cottocemento
- 32 district
- 38 district roc
- 116 ferroemento
- 128 global
- 220 home5+ apuano 5mm
- 224 home5+ material 5mm
- 46 kaleido
- 140 logica
- 144 metropolitan
- 72 morestone
- 148 neutra
- 232 neutra roc 2cm
- 156 salento
- 160 urbandeck
- 166 valencia

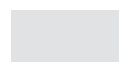

45x90

- 10 artica
- 94 brera
- 26 cosmos
- 46 kaleido
- 80 vulcano

45x45 / 44,5x44,5

10	artica
100	concreta
108	cottoceamento
40	eternity
46	kaleido
140	logica
144	metropolitan
148	neutra
166	valencia

30x60 / 29,7x59,5 / 29,5x59

10	artica
16	artica roc
88	block
20	boulevard
94	brera
190	cave
196	cave roc
100	concreta
26	cosmos
104	cottoantico
108	cottoceamento
198	cremo
32	district
38	district roc
40	eternity
116	ferrocemento
128	global
220	home5+ apuano 5mm
224	home5+ material 5mm
46	kaleido
60	kaleido roc
140	logica
64	luserna
68	luserna roc
144	metropolitan
72	morestone
210	natif light
148	neutra
76	phoenix
156	salento
160	urbandeck
80	volcano

22,5x90

10	artica
46	kaleido
80	volcano

15x90 / 11x90

202	alpi
214	painted
76	phoenix
80	volcano

15x60 / 14,8x59,5

100	concreta
46	kaleido
144	metropolitan
210	natif light
76	phoenix
80	volcano

9,8x59,5

210	natif light
-----	-------------

33,3x33,3

92	borgate fiorentine
138	laredo
140	logica
166	valencia

30x30 / 29,7x29,7

88	block
100	concreta
108	cottoceamento
32	district
40	eternity
44	galapagos
46	kaleido
60	kaleido roc
64	luserna
68	luserna roc
144	metropolitan
148	neutra

20x40

26	cosmos
104	cottoantico

16,5x33,3

92	borgate fiorentine
----	--------------------

15x30

26	cosmos grip
44	galapagos
64	luserna
68	luserna roc

20x20

26	cosmos
104	cottoantico

16,5x16,5 / 15x15 / 14,8x14,8

10	artica
92	borgate fiorentine
32	district
40	eternity
44	galapagos
46	kaleido
68	luserna roc
76	phoenix

Simbologia

SYMBOLICS - SYMBOLES - SYMBOLE - СИМВОЛЫ

GM

GRES PORCELLANATO CON COLORAZIONE IN MASSA
PORCELAINED STONEWARE WITH MASS COLOURING
GRES CERAME AVEC PATE COLOREE
DURCHGEFÄRBTES FEINSTEINZEUG
GRES PORCELLÁNICO CON COLORACIÓN EN MASA
ФАРФОРОВЫЙ КЕРАМОГРАНИТ, ОКРАШЕННЫЙ ПО

GRUPPO DI APPARTENENZA BIA GL
BELONGING TO BLA GL GROUP
GROUPE D'APPARTENANCE BLA GL
ZUGEHÖRIGKEITSGRUPPE BLA GL
GRUPO DE PERTENENCIA BLA GL
ВСЕЙ ТОЛЩИНЕ ГРУППА ПРИНАДЛЕЖНОСТИ BLA GL

GS

GRES PORCELLANATO SMALTATO
GLAZED GRES PORCELAIN
GRES CERAME EMAILLE
GLASIERTES FEINSTEINZEUG
GRES PORCELLÁNICO ESMALTATO
ГЛАЗУРОВАННЫЙ ФАРФОРОВЫЙ КЕРАМОГРАНИТ

GRUPPO DI APPARTENENZA BIA GL
BELONGING TO BLA GL GROUP
GROUPE D'APPARTENANCE BLA GL
ZUGEHÖRIGKEITSGRUPPE BLA GL
GRUPO DE PERTENENCIA BLA GL
ГРУППА ПРИНАДЛЕЖНОСТИ BLA GL



IN CASO DI POSA A CORRERE CON FORMATI RETTANGOLARI SI CONSIGLIA UNA POSA SFALSATA A 1/4.

WITH RUNNING INSTALLATIONS USING RECTANGULAR FORMATS WE RECOMMEND STAGGERING BY 1/4 OF TILE LENGTH.
EN CAS DE POSE DROITE AVEC DES FORMATS RECTANGULAIRES, UNE POSE DECALEE A 1/4 EST RECOMMANDEE.
BEI FORTLAUFENDER VERLEGUNG MIT RECHTECKIGEN FORMATEN EMPFIEHLT SICH EINE VERLEGUNG VERSETZT IM 1/4-VERBAND.
В СЛУЧАЕ УКЛАДКИ ПРЯМОУГОЛЬНЫХ ФОРМАТОВ В РАЗГОН РЕКОМЕНДУЕМ СМЕЩАТЬ ИХ НА.



FUGA MINIMA CONSIGLIATA

ADVISED MINIMUM JOINT
JOINT MINIMAL CONSEILLE
EMPFEHLTE FUGE
МИНИМАЛЬНЫЙ РЕКОМЕНДОВАННЫЙ ШОВ МЕЖДУ ПЛИТКАМИ



DIN 51130 R

CATEGORIE DI RESISTENZA ALLO SCIVOLAMENTO CON PIEDI CALZATI

SLIP RESISTANCE GROUPS WITH FOOTWEAR
CATEGORIES DE RESISTANCE AU GLISSEMENT LES PIEDS CHAUSSES
RUTSCHHEMMUNGSKATEGORIEN MIT SCHUHWERK
КАТЕГОРИИ СОПРОТИВЛЕНИЯ СКОЛЬЖЕНИЮ ПРИ ХОЖДЕНИИ В ОБУВИ

DIN 51097 A+B+C

CATEGORIE DI DESTINAZIONE D'USO PER SUPERFICI CALPESTABILI CON PRESENZA DI ACQUA A PIEDI NUDI

SLIP RESISTANCE GROUPS: BAREFOOT ON WET SURFACE
CATEGORIES DE DESTINATION D'UTILISATION POUR SURFACES PIETINABLES EN PRESENCE D'EAU LES PIEDS NUS
BEANSPRUCHUNGSKATEGORIEN FÜR BARFUSS BEGEBHARE OBERFLÄCHEN BEI NÄSSE
КАТЕГОРИИ НАЗНАЧЕНИЯ ПОВЕРХНОСТЕЙ ПРИ НАЛИЧИИ ВОДЫ И ХОЖДЕНИИ БОСИКОМ

LIVELLO DI STONALIZZAZIONE

COLOR SHADE VARIATIONS
VARIATION DES NUANCES DE COULEUR
CARIATION DER FARBNUANCEN

V1

ASPETTO UNIFORME
UNIFORM APPEARANCE
ASPECT UNIFORME
EINHEITLICHES AUSSEHEN

V2

LIEVE STONALIZZAZIONE
SLIGHT VARIATION
LEGERE VARIATION
GERINGE ABWEICHUNG

V3

MODERATA STONALIZZAZIONE
MODERATE VARIATION
VARIATION MODEREE
MASSIGE ABWEICHUNG

V4

INTENSA STONALIZZAZIONE
SUBSTANTIAL VARIATION
VARIATION INTENSE
INTENSIVE VARIATION

00 ●

FASCIA DI PREZZO ARTICOLI VENDUTI A MQ.

PRICE RANGE FOR ITEMS SOLD PER SQUARE METRE
FOURCHETTE DE PRIX DES ARTICLES VENDUS AU M²
PREISKLASSE PRO QM VERKAUFTE ARTIKEL
ЦЕНОВОЙ СЕГМЕНТ ИЗДЕЛИЙ, ПРОДАВАЕМЫХ ЗА КВ.М

00 ▲

FASCIA DI PREZZO ARTICOLI VENDUTI A PEZZO

PRICE RANGE FOR ITEMS SOLD PER UNIT
FOURCHETTE DE PRIX DES ARTICLES VENDUS A LA PIECE
PREISKLASSE PRO STÜCK VERKAUFTE ARTIKEL
ЦЕНОВОЙ СЕГМЕНТ ИЗДЕЛИЙ, ПРОДАВАЕМЫХ ПОШТУЧНО

00 ◻

PEZZI PER SCATOLA

PIECES PER BOX
PIECES PAR BOITE
STÜCK JE KARTON
ШТУК В КОРОБКЕ



DISPONIBILE SU RICHIESTA

AVAILABLE ON REQUEST
DISPONIBLES SUR DEMANDE
VERFÜGBAR AUF WÜNSCH
ПОСТАВЛЯЕТСЯ ПОЗАКАЗУ

Catalogo Generale
2019

General Catalogue
Catalogue Général
Gesamtkatalog
Общий Каталог

stone effect

effetto pietra

imitation pierre

Steineffekt

Камень

artica
pag. 10



artica roc
pag. 16

boulevard
pag. 20



cosmos
pag. 26

district
pag. 32



district roc
pag. 38

eternity
pag. 40



galapagos
pag. 44

kaleido
pag. 46



kaleido roc
pag. 60

luserna
pag. 64



luserna roc
pag. 68

morestone
pag. 72



phoenix
pag. 76

volcano
pag. 80





artica | stone effect

COLORI

colours - couleurs - farbe - ЦВЕТА

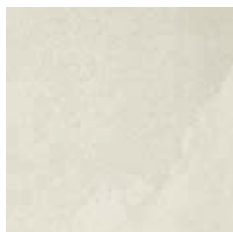

bianco

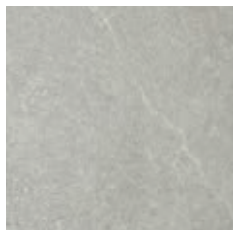

nube



grigio

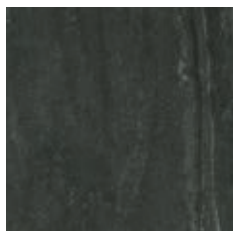

antracite

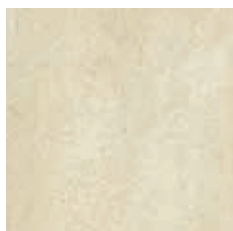

beige

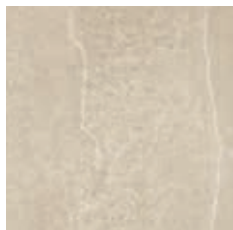

brandy

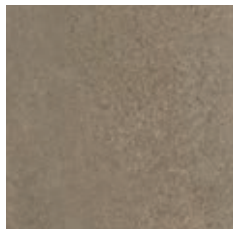

tabacco

FORMATI

sizes - formats - format - ФОРМАТЫ



45x90 (18"x36") RETTIFICATO



22,5x90 (9"x36") RETTIFICATO

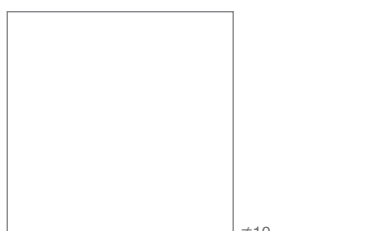

59,5x59,5 (24"x24") RETTIFICATO



30x60 (12"x24") NATURALE
29,7x59,5 (12"x24") RETTIFICATO

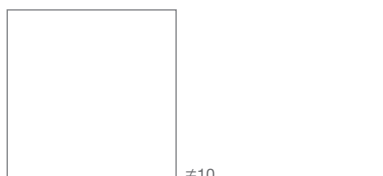

45x45 (18"x18") RETTIFICATO



14,8x14,8 (6"x6") RETTIFICATO

> pag. 16

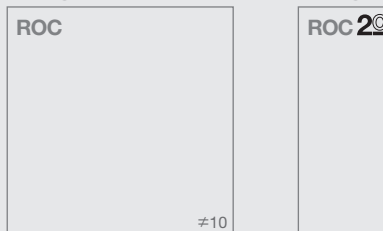

59,5x59,5 (24"x24") RETT.



30x60 (12"x24") NAT.

29,7x59,5 (12"x24") RETT.

> pag. 230



60,5x60,5 (24"x24") RETT.

SUPERFICI
SURFACE
SURFACE
OBERFLACHE
ПОВЕРХНОСТИ

Naturale

Natural
Naturelle
Matt
Натуральный

Lappato

Semi-Polished
Lappato
Halbpoliert
Полуполированный

GM

V3



POSA 1/4



FUGA 2 mm
PER RETTIFICATO



FUGA >3 mm
PER NATURALE

bianco

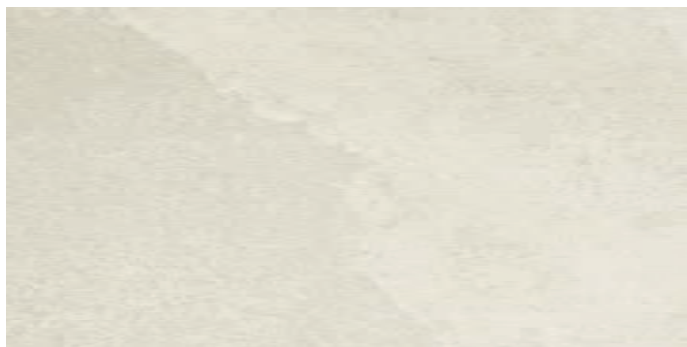

beige

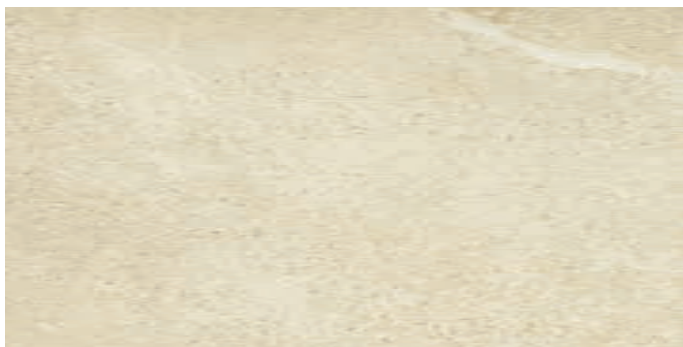

nube



brandy

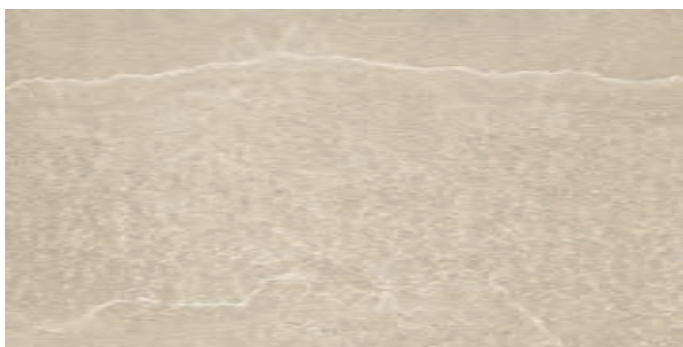

grigio



tabacco



antracite

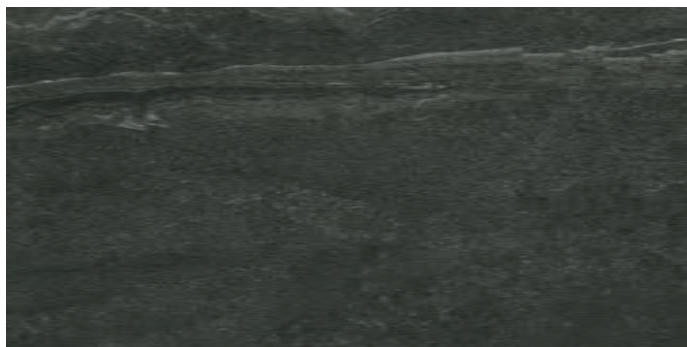



45x90 (18"x36")
rettificato 85 ●
7663815 bianco nat. rett.
7664635 nube nat. rett.
7663835 grigio nat. rett.
7663845 antracite nat. rett.
7663825 beige nat. rett.
7664625 brandy nat. rett.
7664615 tabacco nat. rett.

lappato rettificato 93 ●
7663855 bianco lapp. rett.
7664665 nube lapp. rett.
7663875 grigio lapp. rett.
7663885 antracite lapp. rett.
7663865 beige lapp. rett.
7664655 brandy lapp. rett.
7664645 tabacco lapp. rett.



22,5x90 (9"x36")
rettificato 85 ●
7665415 bianco nat. rett.
7665475 nube nat. rett.
7665435 grigio nat. rett.
7665445 antracite nat. rett.
7665425 beige nat. rett.
7665465 brandy nat. rett.
7665455 tabacco nat. rett.

lappato rettificato 93 ●
7665485 bianco lapp. rett.
7665545 nube lapp. rett.
7665505 grigio lapp. rett.
7665515 antracite lapp. rett.
7665495 beige lapp. rett.
7665535 brandy lapp. rett.
7665525 tabacco lapp. rett.



45x45 (18"x18")
rettificato 85 ●
7663895 bianco nat. rett.
7665195 nube nat. rett.
7663915 grigio nat. rett.
7663925 antracite nat. rett.
7663905 beige nat. rett.
7665185 brandy nat. rett.
7665175 tabacco nat. rett.

lappato rettificato 93 ●
7663935 bianco lapp. rett.
7665405 nube lapp. rett.
7663955 grigio lapp. rett.
7663965 antracite lapp. rett.
7663945 beige lapp. rett.
7665215 brandy lapp. rett.
7665205 tabacco lapp. rett.



59,5x59,5 (24"x24")
rettificato 81 ●
7686335 bianco nat. rett.
7687245 nube nat. rett.
7686355 grigio nat. rett.
7686365 antracite nat. rett.
7686345 beige nat. rett.
7687235 brandy nat. rett.
7687225 tabacco nat. rett.

lappato rettificato 88 ●
7686375 bianco lapp. rett.
7687275 nube lapp. rett.
7686395 grigio lapp. rett.
7686405 antracite lapp. rett.
7686385 beige lapp. rett.
7687265 brandy lapp. rett.
7687255 tabacco lapp. rett.



30x60 (12"x24")
naturale 68 ●
7677815 bianco nat.
7677875 nube nat.
7677835 grigio nat.
7677845 antracite nat.
7677825 beige nat.
7677865 brandy nat.
7677855 tabacco nat.

29,7x59,5 (12"x24")
rettificato 78 ●
7686415 bianco nat. rett.
7678005 nube nat. rett.
7686435 grigio nat. rett.
7686445 antracite nat. rett.
7686425 beige nat. rett.
7677995 brandy nat. rett.
7677985 tabacco nat. rett.

lappato rettificato 86 ●
7686455 bianco lapp. rett.
7678035 nube lapp. rett.
7686475 grigio lapp. rett.
7686485 antracite lapp. rett.
7686465 beige lapp. rett.
7678025 brandy lapp. rett.
7678015 tabacco lapp. rett.



14,8x14,8 (6"x6")
rettificato 99 ●
7661298 bianco nat. rett.
7661278 nube nat. rett.
7661288 grigio nat. rett.
7661268 antracite nat. rett.
7661276 brandy nat. rett.
7661289 tabacco nat. rett.

lappato rettificato 108 ●
7661274 bianco lapp. rett.
7661267 antracite lapp. rett.
7661277 brandy lapp. rett.

mosaico 5x5 (2"x2") 124 ●

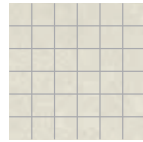

30x30 (12"x12")
7686495 bianco nat.
7686535 bianco lapp.

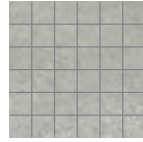

30x30 (12"x12")
7678065 nube nat.
7678095 nube lapp.

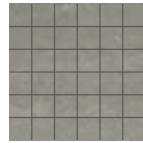

30x30 (12"x12")
7686515 grigio nat.
7686555 grigio lapp.

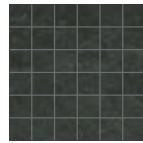

30x30 (12"x12")
7686525 antracite nat.
7686565 antracite lapp.



30x30 (12"x12")
7686505 beige nat.
7686545 beige lapp.



30x30 (12"x12")
7678055 brandy nat.
7678085 brandy lapp.



30x30 (12"x12")
7678045 tabacco nat.
7678075 tabacco lapp.

listellato 131 ●



30x60 (12"x24")
7678555 bianco nat.
7678625 bianco lapp.



30x60 (12"x24")
7678565 nube nat.
7678635 nube lapp.



30x60 (12"x24")
7678575 grigio nat.
7678645 grigio lapp.



30x60 (12"x24")
7678585 antracite nat.
7678655 antracite lapp.



30x60 (12"x24")
7678595 beige nat.
7678665 beige lapp.



30x60 (12"x24")
7678605 brandy nat.
7678675 brandy lapp.



30x60 (12"x24")
7678615 tabacco nat.
7678685 tabacco lapp.

artica

artica stone effect

FORMATI MODULARI Spessore 10 mm

modular sizes - formats modulaires - modulformate

COMPOSIZIONI composition - composition - kombination

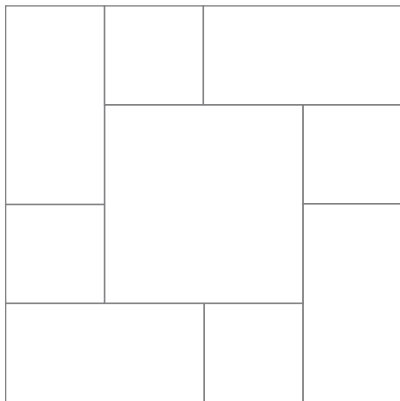

59,5x59,5 rett. 25%
 29,7x59,5 rett. 50%
 29,7x29,7 rett. 25%

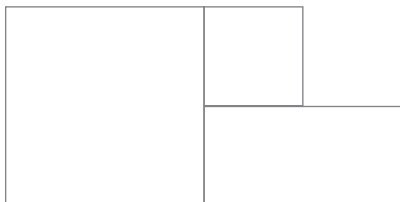

59,5x59,5 rett. 57,2%
 29,7x59,5 rett. 28,5%
 29,7x29,7 rett. 14,3%

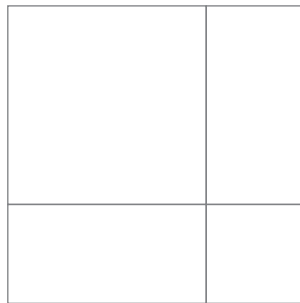

59,5x59,5 rett. 44,5%
 29,7x59,5 rett. 44,4%
 29,7x29,7 rett. 11,1%

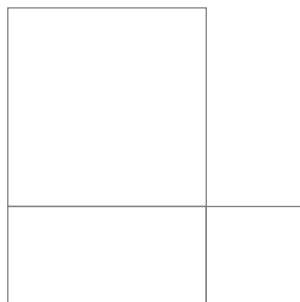

59,5x59,5 rett. 57,2%
 29,7x59,5 rett. 28,5%
 29,7x29,7 rett. 14,3%



59,5x59,5 (24"x24")
rettificato #10 81 ●
 7686365 antracite nat. rett. #10
 7686345 beige nat. rett. #10
 7686335 bianco nat.rett. #10
 7687235 brandy nat. rett. #10
 7686355 grigio nat.rett. #10
 7687245 nube nat.rett. #10
 7687225 tabacco nat. rett. #10



29,7x59,5 (12"x24")
rettificato #10 81 ●
 7690475 antracite nat. rett. #10
 7690425 beige nat. rett. #10
 7690445 bianco nat.rett. #10
 7690435 brandy nat. rett. #10
 7690465 grigio nat.rett. #10
 7690455 nube nat.rett. #10
 7690415 tabacco nat. rett. #10



29,7x29,7 (12"x12")
rettificato #10 81 ●
 7690405 antracite nat. rett. #10
 7690355 beige nat. rett. #10
 7690375 bianco nat.rett. #10
 7690365 brandy nat. rett. #10
 7690395 grigio nat.rett. #10
 7690385 nube nat.rett. #10
 7690345 tabacco nat. rett. #10

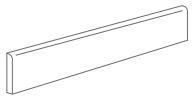

battiscopa naturale

7,5x60 (3"x24")

- 7678825 antracite nat.
- 7678795 beige nat.
- 7678855 bianco nat.
- 7678805 brandy nat.
- 7678835 grigio nat.
- 7678845 nube nat.
- 7678815 tabacco nat.

24 ▲ 14 📦

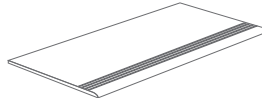

gradino step naturale

30x60 (12"x24")

- 7678874 antracite nat.
- 7678879 beige nat.
- 7678880 bianco nat.
- 7678877 brandy nat.
- 7678881 grigio nat.
- 7678882 nube nat.
- 7678878 tabacco nat.

48 ▲ 7 📦

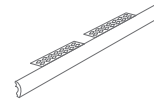

*** torelo gradino nat. rett.**

4x59,5 (1,5"x24")

- 7675090 antracite nat. rett.
- 7675068 beige nat. rett.
- 7675069 bianco nat. rett.
- 7675082 brandy nat. rett.
- 7675087 grigio nat. rett.
- 7675084 nube nat. rett.
- 7675092 tabacco nat. rett.

99 ▲ 4 📦

battiscopa naturale rett.

7,5x59,5 (3"x24")

- 7678365 antracite nat. rett.
- 7678375 beige nat. rett.
- 7678335 bianco nat. rett.
- 7678385 brandy nat. rett.
- 7678355 grigio nat. rett.
- 7678345 nube nat. rett.
- 7678395 tabacco nat. rett.

24 ▲ 14 📦

gradino step naturale rett.

29,7x59,5 (12"x24")

- 7686446 antracite nat. rett.
- 7686426 beige nat. rett.
- 7686416 bianco nat. rett.
- 7677996 brandy nat. rett.
- 7686436 grigio nat. rett.
- 7678006 nube nat. rett.
- 7677987 tabacco nat. rett.

48 ▲ 7 📦

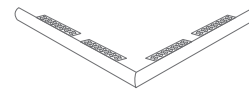

*** torelo set angolare nat. rett.**

4x59,5 (1,5"x24")

- 7675093 antracite nat. rett.
- 7675078 beige nat. rett.
- 7675079 bianco nat. rett.
- 7675080 brandy nat. rett.
- 7675086 grigio nat. rett.
- 7675083 nube nat. rett.
- 7675088 tabacco nat. rett.

126 ▲ 2 set 📦







battiscopa lappato rett.

7,5x59,5 (3"x24")

- 7678337 antracite lapp. rett.
- 7678338 beige lapp. rett.
- 7678336 bianco lapp. rett.
- 7678339 brandy lapp. rett.
- 7678340 grigio lapp. rett.
- 7678346 nube lapp. rett.
- 7678347 tabacco lapp. rett.

24 ▲ 14 📦

IMBALLI packing - emballages - verpackung - УПАКОВКА

F.TO NOMINALE / NOMINAL SIZE	 mm.	 PCS / BOX	 M2 / BOX	 BOX / PLT	 M2 / PLT	 KG. / PLT
45x90 rett.	10	3	1,215	30	36,45	840
22,5x90 rett.	10	6	1,215	36	43,74	972
59,5x59,5 rett.	10	3	1,062	40	42,48	960
45x45 rett.	10	6	1,22	26	31,72	655,20
30x60	9	7	1,26	40	50,40	989
29,7x59,5 rett.	9	7	1,24	40	49,60	973
30x30 mosaico	9	11	1	-	-	-
30x60 listellato	9	4	0,72	-	-	-
59,5x59,5 rett. sp.10	10	3	1,062	40	42,48	960
29,7x59,5 rett. sp.10	10	7	1,24	36	44,64	1008
29,7x29,7 rett. sp.10	10	11	0,97	46	44,62	1012



COLORI

colours - couleurs - farbe - ЦВѢТА



bianco



beige



brandy



tabacco



nube



grigio

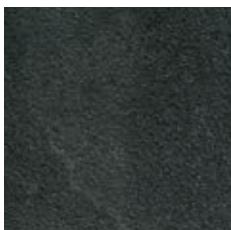

antracite

FORMATI

sizes - formats - format - ФОРМАТЫ



≠10

59,5x59,5 (24"x24") RETTIFICATO



≠9

30x60 (12"x24") NATURALE

29,7x59,5 (12"x24") RETTIFICATO

GM

V3



POSA 1/4



FUGA 2 mm
PER RETTIFICATO



FUGA >3 mm
PER NATURALE



DIN 51130
R11



DIN 51097
A+B+C

bianco roc



beige roc



59,5x59,5 (24" x 24")
rettificato #10 81 ●
 7688655 bianco roc rett.
 7688675 nube roc rett.
 7688695 grigio roc rett.
 7688665 beige roc rett.
 7688685 brandy roc rett.
 7688715 antracite roc rett.
 7688705 tabacco roc rett.

nube roc



brandy roc



30x60 (12" x 24")
naturale #9 68 ●
 7678925 bianco roc
 7678915 nube roc
 7678905 grigio roc
 7678895 antracite roc
 7678865 beige roc
 7678875 brandy roc
 7678885 tabacco roc

grigio roc

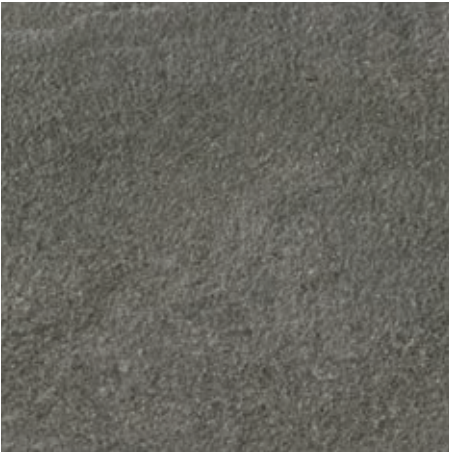

tabacco roc



29,7x59,5 (12" x 24")
rettificato #9 78 ●
 7678985 bianco roc rett.
 7678995 nube roc rett.
 7678975 grigio roc rett.
 7678965 antracite roc rett.
 7678935 beige roc rett.
 7678945 brandy roc rett.
 7678955 tabacco roc rett.

antracite roc



mosaico 5x5 (2" x 2") 124 ●



30x30 (12"x12")
 7679905 bianco roc

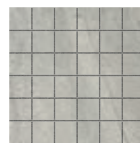

30x30 (12"x12")
 7679925 nube roc



30x30 (12"x12")
 7679915 grigio roc

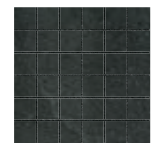

30x30 (12"x12")
 7679935 antracite roc



30x30 (12"x12")
 7679895 beige roc



30x30 (12"x12")
 7679955 brandy roc



30x30 (12"x12")
 7679945 tabacco roc

FORMATI MODULARI Spessore 10 mm

modular sizes - formats modulaires - modulformate

artica roc

COMPOSIZIONI composition - composition - kombination

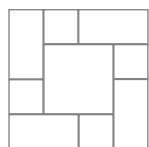

59,5x59,5 rett. 25%
29,7x59,5 rett. 50%
29,7x29,7 rett. 25%

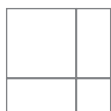

59,5x59,5 rett. 44,5%
29,7x59,5 rett. 44,4%
29,7x29,7 rett. 11,1%



59,5x59,5 rett. 57,2%
29,7x59,5 rett. 28,5%
29,7x29,7 rett. 14,3%

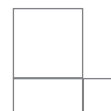

59,5x59,5 rett. 57,2%
29,7x59,5 rett. 28,5%
29,7x29,7 rett. 14,3%



59,5x59,5 (24"x24")
rettificato ±10 81 ●
7688715 antracite roc rett. ±10
7688665 beige roc rett. ±10
7688655 bianco rocret. ±10
7688685 brandy roc rett. ±10
7688695 grigio roc rett. ±10
7688675 nube roc rett. ±10
7688705 tabacco roc rett. ±10



29,7x59,5 (12"x24")
rettificato ±10 81 ●
7690615 antracite roc rett. ±10
7690565 beige roc rett. ±10
7690585 bianco rocret. ±10
7690575 brandy roc rett. ±10
7690605 grigio roc rett. ±10
7690595 nube roc rett. ±10
7690555 tabacco roc rett. ±10



29,7x29,7 (12"x12")
rettificato ±10 81 ●
7690545 antracite roc rett. ±10
7690495 beige roc rett. ±10
7690515 bianco rocret. ±10
7690505 brandy roc rett. ±10
7690535 grigio roc rett. ±10
7690525 nube roc rett. ±10
7690485 tabacco roc rett. ±10

PEZZI SPECIALI trims - pieces speciales - formstücke - СОБИЕЭЛЕМЕНТЫ

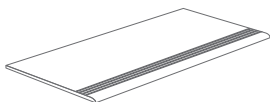

Gradino Step
30x60 (12"x24")
7678896 Antracite Roc
7678866 Beige Roc
7678926 Bianco Roc
7678876 Brandy Roc
7678906 Grigio Roc
7678916 Nube Roc
7678886 Tabacco Roc

48 ▲ 7 ☐



Elemento Elle Pressa Roc
15x30x3,5 (6"x12"x 1,4")
7686566 Antracite Roc
7686546 Beige Roc
7686496 Bianco Roc
7686086 Brandy Roc
7686556 Grigio Roc
7678096 Nube Roc
7678076 Tabacco Roc

44 ▲ 8 ☐

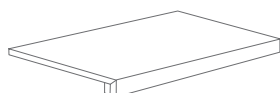

*** Gradone DP Rett.**
33,3x59,5 (13"x24")
7690184 Antracite Roc
7690194 Beige Roc
7690204 Bianco Roc
7690217 Brandy Roc
7690224 Grigio Roc
7690234 Nube Roc
7690244 Tabacco Roc

111 ▲ 4 ☐

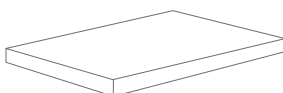

*** Angolare DP SX Rett.**
33,3x59,5 (13"x24")
7690187 Antracite Roc
7690197 Beige Roc
7690207 Bianco Roc
7690218 Brandy Roc
7690227 Grigio Roc
7690239 Nube Roc
7690247 Tabacco Roc

119 ▲ 2 ☐

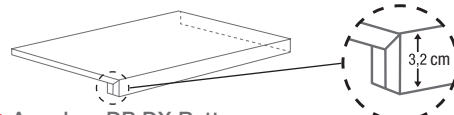

*** Angolare DP DX Rett.**
33,3x59,5 (13"x24")
7690188 Antracite Roc
7690198 Beige Roc
7690208 Bianco Roc
7690219 Brandy Roc
7690228 Grigio Roc
7690240 Nube Roc
7690248 Tabacco Roc

119 ▲ 2 ☐

IMBALLI packing - emballages - verpackung - УПАКОВКА

F.TO NOMINALE / NOMINAL SIZE	mm.	PCS / BOX	M2 / BOX	BOX / PLT	M2 / PLT	KG. / PLT
59,5x59,5 rett.	10	3	1,062	40	42,48	960
30x60	9	7	1,26	40	50,40	989
29,7x59,5 rett.	9	7	1,24	40	49,60	973
30x30 mosaico	9	11	1	-	-	-
59,5x59,5 rett. sp.10	10	3	1,062	40	42,48	960
29,7x59,5 rett. sp.10	10	7	1,24	36	44,64	1008
29,7x29,7 rett. sp.10	10	11	0,97	46	44,62	1012



boulevard | stone effect

COLORI

colours - couleurs - farbe - ЦВЕТА



white



grey



sand



taupe

FORMATI

sizes - formats - format - ФОРМАТЫ

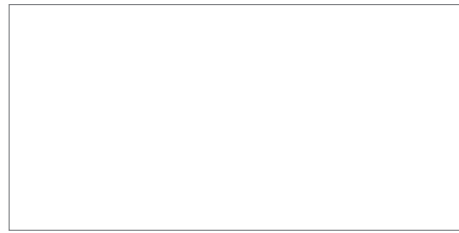

≠10

60x120 (24"x47") RETTIFICATO



≠10

30x120 (12"x47") RETTIFICATO



≠10

59,5x59,5 (24"x24") RETTIFICATO



≠9

30x60 (12"x24")

29,7x59,5 (12"x24") RETTIFICATO



POSA 1/4



FUGA 2 mm
PER RETTIFICATO



FUGA >3 mm
PER NATURALE

white



sand



grey



taupe





60x120 (24"x47")
rettificato 91 ●
 7648265 white rett.
 7648285 grey rett.
 7648275 sand rett.
 7648295 taupe rett.



30x120 (12"x47")
rettificato 91 ●
 7648305 white rett.
 7648325 grey rett.
 7648315 sand rett.
 7648335 taupe rett.



59,5x59,5 (24"x24")
rettificato 81 ●
 7648535 white rett.
 7648545 grey rett.
 7648555 sand rett.
 7648565 taupe rett.



30x60 (12"x24")
naturale 68 ●
 7681045 white nat.
 7681055 grey nat.
 7681065 sand nat.
 7681075 taupe nat.

29,7x59,5 (12"x24")
rettificato 78 ●
 7681085 white rett.
 7681095 grey rett.
 7681105 sand rett.
 7681115 taupe rett.

mosaico 5x5 (2"x2") 124 ●



30x30 (12"x12")
 7681125 white



30x30 (12"x12")
 7681145 sand



30x30 (12"x12")
 7681135 grey



30x30 (12"x12")
 7681155 taupe

listellato 131 ●



30x60 (12"x24")
 7681165 white



30x60 (12"x24")
 7681175 grey



30x60 (12"x24")
 7681185 sand



30x60 (12"x24")
 7681195 taupe

PEZZI SPECIALI trims - pieces speciales - formstücke - СОБИЕЭЛЕМЕНТЫ

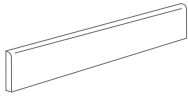

battiscopa naturale

7,5x60 (3"x24")
7681077 taupe nat.
7681107 sand nat.
7681046 white nat.
7681056 grey nat.

24 ▲ 14 ◻

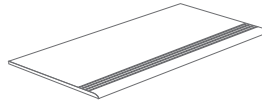

gradino step naturale

30x60 (12"x24")
7681121 taupe nat.
7681120 sand nat.
7681088 white nat.
7681098 grey nat.

48 ▲ 7 ◻

battiscopa rettificato

7,5x59,5 (3"x24")
7681078 taupe rett.
7681108 sand rett.
7681047 white rett.
7681057 grey rett.

24 ▲ 14 ◻

gradino step rettificato

29,7x59,5 (12"x24")
7681118 taupe rett.
7681117 sand rett.
7681087 white rett.
7681097 grey rett.

48 ▲ 7 ◻



*** gradone CR rett.**
33,3x59,5 (13"x24") 7648566 taupe rett.

7648556 sand rett.
7648536 white rett.
7648546 grey rett.

119 ▲ 2 ◻



*** angolare CR SX rett.**

33,3x59,5 (13"x24")
7648567 taupe rett.
7648557 sand rett.
7648537 white rett.
7648547 grey rett.

130 ▲ 2 ◻

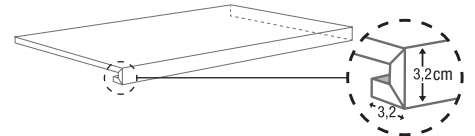

*** angolare CR DX rett.**

33,3x59,5 (13"x24")
7648568 taupe rett.
7648558 sand rett.
7648538 white rett.
7648548 grey rett.

130 ▲ 2 ◻

IMBALLI packing - emballages - verpackung - УПАКОВКА

F.TO NOMINALE / NOMINAL SIZE	mm.	PCS / BOX	M2 / BOX	BOX / PLT	M2 / PLT	KG. / PLT
60x120 rett.	10	2	1,44	36	51,84	1152
30x120 rett.	10	3	1,08	20	21,60	480
59,5x59,5 rett.	10	3	1,062	40	42,48	960
30x60	9	7	1,26	40	50,40	989
29,7x59,5 rett.	9	7	1,24	40	49,60	973
30x30 mosaico	9	11	1	-	-	-
30x60 listellato	9	4	0,72	-	-	-



boulevard | stone effect



cosmos | stone effect

COLORI

colours - couleurs - farbe - ЦВЕТА



gesso



calcare



cemento



ossido



grafite

FORMATI

sizes - formats - format - ФОРМАТЫ

naturale



45x90 (18"x36") RETTIFICATO



30x60 (12"x24") NATURALE
29,7x59,5 (12"x24") RETTIFICATO



20x40 (8"x16")



20x20 (8"x8")

grip



45x90 (18"x36") RETTIFICATO

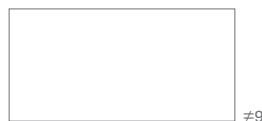

30x60 (12"x24") NATURALE
29,7x59,5 (12"x24") RETTIFICATO



15x30 (6"x12")

SUPERFICI
SURFACE
SURFACE
OBERFLACHE
ПОВЕРХНОСТИ

Naturale

Natural
Naturelle
Matt

Натуральный

Grip

Grip
Grip
Grip
Grip
Grip



POSA 1/4



FUGA 2 mm
PER RETTIFICATO



FUGA >3 mm
PER NATURALE



DIN 51130
R11
(GRIP)



DIN 51097
A+B+C
(GRIP)

gesso



calcare



cemento



ossido



grafite



naturale



45x90 (18"x36")
rettificato 85 ●
7600021 gesso rett.
7960081 calcare rett.
7600031 cemento rett.
7600041 ossido rett.
7600051 grafite rett.



30x60 (12"x24")
naturale 68 ●
7679271 gesso nat.
7679261 calcare nat.
7679291 cemento nat.
7679301 ossido nat.
7679281 grafite nat.

29,7x59,5 (12"x24")
rettificato 78 ●
7679311 gesso rett.
7679351 calcare rett.
7679321 cemento rett.
7679331 ossido rett.
7679341 grafite rett.



20x40 (8"x16")
naturale 68 ●
7603601 gesso nat.
7603591 calcare nat.
7603611 cemento nat.
7603621 ossido nat.
7603631 grafite nat.



20x20 (8"x8")
naturale 68 ●
7603291 gesso nat.
7603281 calcare nat.
7603301 cemento nat.
7603311 ossido nat.
7603321 grafite nat.

grip



45x90 (18"x36")
grip rettificato 85 ●
7600791 gesso grip rett.
7600781 calcare grip rett.
7600801 cemento grip rett.
7600761 ossido grip rett.
7600771 grafite grip rett.



30x60 (12"x24")
grip 68 ●
7679371 gesso grip
7679361 calcare grip
7679381 cemento grip
7679391 ossido grip
7679401 grafite grip

29,7x59,5 (12"x24")
grip rettificato 78 ●
7679421 gesso grip rett.
7679411 calcare grip rett.
7679431 cemento grip rett.
7679441 ossido grip rett.
7679451 grafite grip rett.



15x30 (6"x12")
grip 62 ●
7700371 gesso grip
7700411 calcare grip
7700381 cemento grip
7700391 ossido grip
7700401 grafite grip

mosaico 5x5 (2"x2") 124 ●



30x30 (12"x12")
7679531 gesso nat.



30x30 (12"x12")
7679571 calcare nat.

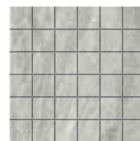

30x30 (12"x12")
7679541 cemento nat.



30x30 (12"x12")
7679551 ossido nat.

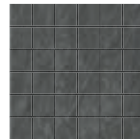

30x30 (12"x12")
7679561 grafite nat.

naturale

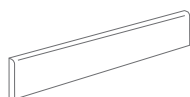

battiscopa naturale
7,5x60 (3"x24")
7676262 calcare nat.
7676292 cemento nat.
7676272 gesso nat.
7676282 grafite nat.
7676702 ossido nat.

24 ▲ 14 ☐

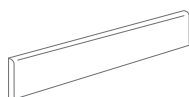

battiscopa rett.
7,5x59,5 (3"x24")
7676264 calcare rett.
7676294 cemento rett.
7676274 gesso rett.
7676284 grafite rett.
7676704 ossido rett.

24 ▲ 14 ☐

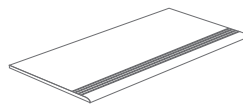

gradino step naturale
30x60 (12"x24")
7676263 calcare nat.
7676293 cemento nat.
7676273 gesso nat.
7679283 grafite nat.
7679703 ossido nat.

48 ▲ 7 ☐

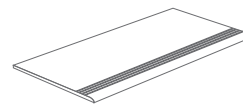

gradino step rett.
29,7x59,5 (12"x24")
7676265 calcare rett.
7676295 cemento rett.
7676275 gesso rett.
7676285 grafite rett.
7679705 ossido rett.

48 ▲ 7 ☐

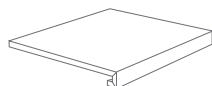

*** gradone CR rett.**
33,3x29,7 (13"x12")
7676266 calcare rett.
7676386 cemento rett.
7676276 gesso rett.
7676286 grafite rett.
7679706 ossido rett.

89 ▲ 4 ☐



*** angolare CR SX rett.**
33,3x29,7 (13"x12")
7676268 calcare rett.
7676387 cemento rett.
7676277 gesso rett.
7676287 grafite rett.
7679707 ossido rett.

118 ▲ 2 ☐

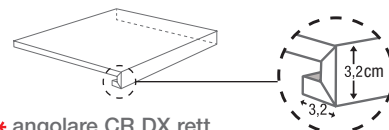

*** angolare CR DX rett.**
33,3x29,7 (13"x12")
7676267 calcare rett.
7676388 cemento rett.
7676278 gesso rett.
7676288 grafite rett.
7679708 ossido rett.

118 ▲ 2 ☐

grip

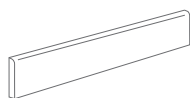

battiscopa grip
7,5x60 (3"x24")
7679362 calcare grip
7679382 cemento grip
7679372 gesso grip
7679402 grafite grip
7679392 ossido grip

24 ▲ 14 ☐

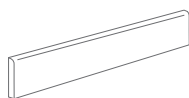

battiscopa grip rett.
7,5x59,5 (3"x24")
7679364 calcare grip rett.
7676384 cemento grip rett.
7679374 gesso grip rett.
7679404 grafite grip rett.
7676394 ossido grip rett.

24 ▲ 14 ☐

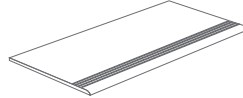

gradino step grip
30x60 (12"x24")
7679363 calcare grip
7679383 cemento grip
7679373 gesso grip
7679403 grafite grip
7679393 ossido grip

48 ▲ 7 ☐

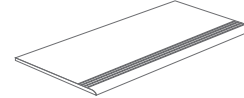

gradino step grip rett.
29,7x59,5 (12"x24")
7676364 calcare grip rett.
7676383 cemento grip rett.
7676375 gesso grip rett.
7676405 grafite grip rett.
7679793 ossido grip rett.

48 ▲ 7 ☐

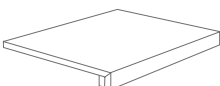

*** gradone DP grip rett.**
33,3x29,7 (13"x12")
7676269 calcare grip rett.
7676389 cemento grip rett.
7676279 gesso grip rett.
7679287 grafite grip rett.
7679709 ossido grip rett.

78 ▲ 4 ☐



*** angolare DP SX grip rett.**
33,3x29,7 (13"x12")
7676270 calcare grip rett.
7679390 cemento grip rett.
7679280 gesso grip rett.
7679288 grafite grip rett.
7679710 ossido grip rett.

102 ▲ 2 ☐

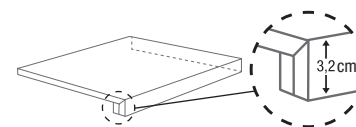

*** angolare DP DX grip rett.**
33,3x29,7 (13"x12")
7679270 calcare grip rett.
7676390 cemento grip rett.
7676280 gesso grip rett.
7679289 grafite grip rett.
7679711 ossido grip rett.

102 ▲ 2 ☐



elemento elle pressa grip
15x30x3,5 (6"x12"x1,4")
7679365 calcare grip
7679367 cemento grip
7679366 gesso grip
7679368 grafite grip
7679369 ossido grip

44 ▲ 8 ☐

IMBALLI packing - emballages - verpackung - УПАКОВКА

F.TO NOMINALE / NOMINAL SIZE	mm.	PCS / BOX	M2 / BOX	BOX / PLT	M2 / PLT	KG. / PLT
45x90 rett.	10	3	1,215	30	36,45	840
30x60	9	7	1,26	40	50,40	989
29,7x59,5 rett.	9	7	1,24	40	49,60	973
20x40	8,3	18	1,44	56	80,64	1359
20x20	8,3	30	1,20	68	81,60	1346,40
15x30	8	23	1,04	75	78,00	1239
30x30 mosaico 5x5	9	11	1,00	-	-	-



cosmos | stone effect



district | stone effect

COLORI

colours - couleurs - farbe - ЦВЕТА



bianco



beige



tortora



grigio



nero

FORMATI

sizes - formats - format - ФОРМАТЫ

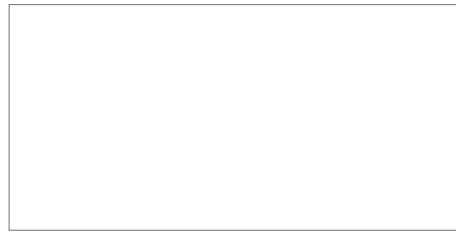

60x120 (24"x47") RETTIFICATO

≠10



30x120 (12"x47") RETTIFICATO

≠10



59,5x59,5 (24"x24") RETTIFICATO

≠10



29,7x59,5 (12"x24") RETTIFICATO

≠10



29,7x29,7 (12"x12") RETTIFICATO

≠10



15x15 (6"x6") NATURALE

≠8

SUPERFICI
SURFACE
SURFACE
OBERFLACHE
ПОВЕРХНОСТИ

Naturale

Natural

Naturelle

Matt

Натуральный

Lappato

Semi-Polished

Lappato

Halbpoliert

Полуполированный



POSA 1/4



FUGA 2 mm
PER RETTIFICATO



FUGA >3 mm
PER NATURALE

> pag. 38

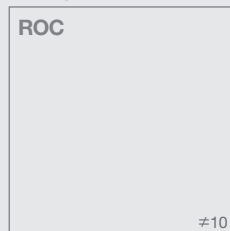

59,5x59,5 (24"x24") RETT.

≠10

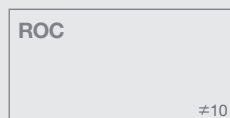

29,7x59,5 (12"x24") RETT.

≠10

bianco



beige



tortora



grigio



nero





60x120 (24"x47")
naturale rettificato 91 ●
 7648075 bianco nat. rett.
 7648085 grigio nat. rett.
 7648095 nero nat. rett.
 7648065 beige nat. rett.
 7648105 tortora nat. rett.

lappato rettificato 99 ●
 7648125 bianco lapp. rett.
 7648135 grigio lapp. rett.
 7648145 nero lapp. rett.
 7648115 beige lapp. rett.
 7648155 tortora lapp. rett.

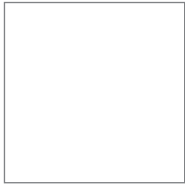

59,5x59,5 (24"x24")
naturale rettificato 81 ●
 7688905 bianco nat. rett.
 7688915 grigio nat. rett.
 7688925 nero nat. rett.
 7688895 beige nat. rett.
 7688935 tortora nat. rett.

lappato rettificato 88 ●
 7688955 bianco lapp. rett.
 7688965 grigio lapp. rett.
 7688975 nero lapp. rett.
 7688945 beige lapp. rett.
 7688985 tortora lapp. rett.



29,7x29,7 (12"x12")
naturale rettificato 81 ●
 7689105 bianco nat. rett.
 7689125 grigio nat. rett.
 7689145 nero nat. rett.
 7689095 beige nat. rett.
 7689155 tortora nat. rett.

lappato rettificato 88 ●
 7689195 bianco lapp. rett.
 7689205 grigio lapp. rett.
 7689215 nero lapp. rett.
 7689185 beige lapp. rett.
 7689225 tortora lapp. rett.



30x120 (12"x47")
naturale rettificato 91 ●
 7649175 bianco nat. rett.
 7649185 grigio nat. rett.
 7649195 nero nat. rett.
 7649215 beige nat. rett.
 7649205 tortora nat. rett.

lappato rettificato 99 ●
 7649225 bianco lapp. rett.
 7649235 grigio lapp. rett.
 7649245 nero lapp. rett.
 7649265 beige lapp. rett.
 7649255 tortora lapp. rett.



29,7x59,5 (12"x24")
naturale rettificato 81 ●
 7689005 bianco nat. rett.
 7689015 grigio nat. rett.
 7689025 nero nat. rett.
 7688995 beige nat. rett.
 7689035 tortora nat. rett.

lappato rettificato 88 ●
 7689055 bianco lapp. rett.
 7689065 grigio lapp. rett.
 7689075 nero lapp. rett.
 7689045 beige lapp. rett.
 7689085 tortora lapp. rett.



15x15 (6"x6")
naturale 62 ●
 7697401 bianco nat.
 7697391 grigio nat.
 7697421 nero nat.
 7697411 beige nat.
 7697431 tortora nat.

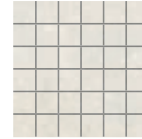

30x30 (12"x12")
 7689245 bianco nat.

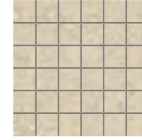

30x30 (12"x12")
 7689235 beige nat.

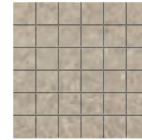

30x30 (12"x12")
 7690305 tortora nat.

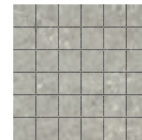

30x30 (12"x12")
 7689255 grigio nat.

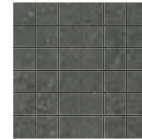

30x30 (12"x12")
 7689265 nero nat.

PEZZI SPECIALI trims - pieces speciales - formstücke - СОБЫЕЭЛЕМЕНТЫ



battiscopa naturale rett.

7,5x59,5 (3"x24")

7688896 beige nat. rett.
7688906 bianco nat. rett.
7688916 grigio nat. rett.
7688826 nero nat. rett.
7688936 tortora nat. rett.

24 ▲ 14 ◻

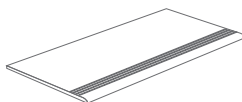

gradino step naturale rett.

29,7x59,5 (12"x24")

7688897 beige nat. rett.
7688907 bianco nat. rett.
7688917 grigio nat. rett.
7688927 nero nat. rett.
7688837 tortora nat. rett.

48 ▲ 7 ◻

battiscopa lappato rett.

7,5x59,5 (3"x24")

7688946 beige lapp. rett.
7688956 bianco lapp. rett.
7688966 grigio lapp. rett.
7688976 nero lapp. rett.
7688986 tortora lapp. rett.

24 ▲ 14 ◻

gradino step lappato rett.

29,7x59,5 (12"x24")

7688947 beige lapp. rett.
7688957 bianco lapp. rett.
7688967 grigio lapp. rett.
7688977 nero lapp. rett.
7688987 tortora lapp. rett.

53 ▲ 7 ◻



*** gradone CR rett.**

33,3x59,5 (13"x24")

7688898 beige nat.
7688908 bianco nat.
7688918 grigio nat.
7688828 nero nat.
7688938 tortora nat.

119 ▲ 4 ◻



*** angolare CR SX rett.**

33,3x59,5 (13"x24")

7688900 beige nat.
7688910 bianco nat.
7688920 grigio nat.
7688930 nero nat.
7688940 tortora nat.

130 ▲ 2 ◻

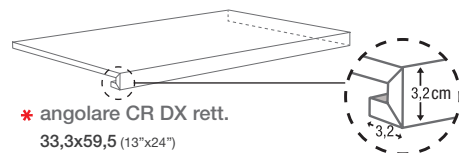

*** angolare CR DX rett.**

33,3x59,5 (13"x24")

7688899 beige nat.
7688909 bianco nat.
7688919 grigio nat.
7688929 nero nat.
7688939 tortora nat.

130 ▲ 2 ◻

district | stone effect

IMBALLI packing - emballages - verpackung - УПАКОВКА

F.TO NOMINALE / NOMINAL SIZE	mm.	PCS / BOX	M2 / BOX	BOX / PLT	M2 / PLT	KG. / PLT
60x120 rett.	10	2	1,44	36	51,84	1152
30x120 rett.	10	3	1,08	20	21,60	480
59,5x59,5 rett.	10	3	1,062	40	42,48	960
29,7x59,5 rett.	10	7	1,24	36	44,64	972
29,7x29,7 rett.	10	11	0,97	48	46,56	1056
15x15	8	46	1,04	75	78	1200
30x30 mosaico	10	11	1,00	-	-	-

district

district | stone effect



bianco roc



grigio roc



59,5x59,5 (24"x24")
rettificato 81 ●
 7694135 bianco roc rett.
 7694155 grigio roc rett.
 7694165 nero roc rett.
 7694145 tortora roc rett.



29,7x59,5 (12"x24")
rettificato 81 ●
 7694175 bianco roc rett.
 7694195 grigio roc rett.
 7694205 nero roc rett.
 7694185 tortora roc rett.

tortora roc



nero roc

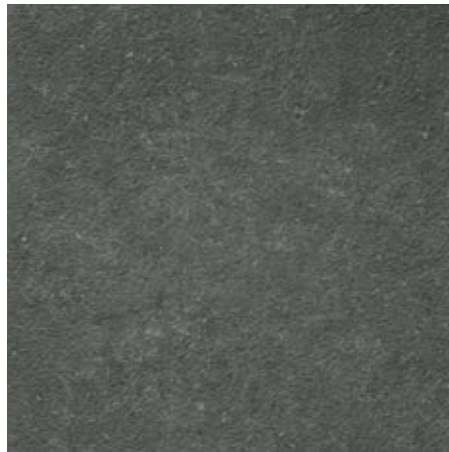

POSA 1/4



FUGA >3 mm

PEZZI SPECIALI trims - pieces speciales - formstücke - СОБЫЕЭЛЕМЕНТЫ

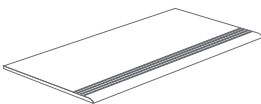

gradino step rettificato
 29,7x59,5 (12"x24")
 7694176 bianco roc rett.
 7694196 grigio roc rett.
 7694206 nero roc rett.
 7694186 tortora roc rett.

48 ▲ 7 ◻



DIN 51130
 R11



DIN 51097
 A+B+C

IMBALLI packing - emballages - verpackung - УПАКОВКА

F.TO NOMINALE / NOMINAL SIZE	mm.	PCS / BOX	M2 / BOX	BOX / PLT	M2 / PLT	KG. / PLT
59,5x59,5 rett.	10	3	1,062	40	42,48	890
29,7x59,5 rett.	10	7	1,24	40	49,60	1100



eternity _ stone effect

COLORI

colours - couleurs - farbe - ЦВЕТА

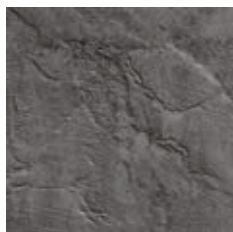

black



grey



almond



gold



forest

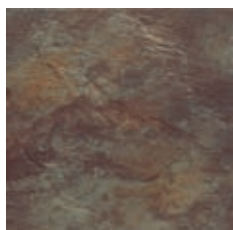

multicolor

FORMATI

sizes - formats - format - ФОРМАТЫ



≠9

30x60 (12"x24") NATURALE

29,7x59,5 (12"x24") RETTIFICATO



≠9

45x45 (18"x18") NATURALE

44,5x44,5 (18"x18") RETTIFICATO



≠8

30x30 (12"x12") NATURALE

29,7x29,7 (12"x12") RETTIFICATO



15x15 (6"x6") NATURALE ≠8

14,8x14,8 (6"x6") RETTIFICATO ≠9

GM

V2

BLACK
GREY
ALMOND
GOLD

V3

FOREST
MULTICOLOR



POSA 1/4



FUGA 2 mm
PER RETTIFICATO



FUGA >3 mm
PER NATURALE



DIN 51130
R10



DIN 51097
A+B

almond



30x60 (12"x24")
naturale 68 ●
 6500371 almond nat.
 6500391 gold nat.
 6500381 forest nat.
 6500401 multicolor nat.
 7670965 grey nat.
 7670975 black nat.

gold



29,7x59,5 (12"x24")
rettificato 78 ●
 6500411 almond rett.
 6500481 gold rett.
 6500421 forest rett.
 6500491 multicolor rett.
 7670985 grey rett.
 7670995 black rett.

forest



45x45 (18"x18")
naturale 62 ●
 6411351 almond nat.
 6411371 gold nat.
 6411361 forest nat.
 6411381 multicolor nat.
 7671025 grey nat.
 7671031 black nat.

multicolor

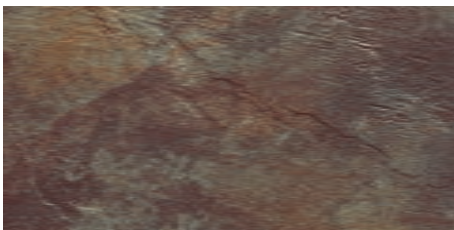

44,5x44,5 (18"x18")
rettificato 76 ●
 6411391 almond rett.
 6411411 gold rett.
 6411401 forest rett.
 6411421 multicolor rett.
 7671041 grey rett.
 7671051 black rett.

grey



30x30 (12"x12")
naturale 62 ●
 6434451 almond nat.
 6434471 gold nat.
 6434461 forest nat.
 6434481 multicolor nat.
 7671141 grey nat.
 7671151 black nat.



15x15 (6"x6")
naturale 78 ●
 6434531 almond nat.
 6434551 gold nat.
 6434541 forest nat.
 6434561 multicolor nat.
 7671101 grey nat.
 7671111 black nat.

black

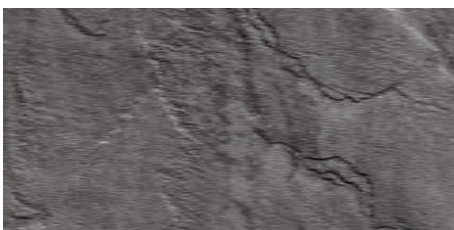

29,7x29,7 (12"x12")
rettificato 78 ●
 6434851 almond rett.
 6434871 gold rett.
 6434861 forest rett.
 6434881 multicolor rett.
 7671161 grey rett.
 7671171 black rett.

14,8x14,8 (6"x6")
rettificato 87 ●
 6434891 almond rett.
 6434911 gold rett.
 6434901 forest rett.
 6434921 multicolor rett.
 7671121 grey rett.
 7671131 black rett.

mosaico 3x3 (1,2"x1,2") 147 ●



30x30 (12"x12")
7668871 mix caldo

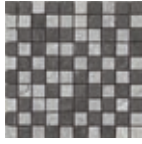

30x30 (12"x12")
7673201 mix freddo

muretto 2,5x5 (1"x2") 139 ●



30x30 (12"x12")
7668861 mix caldo



30x30 (12"x12")
7673191 mix freddo

listello metal



2,5x20 (1"x8")
6434849

6 ▲
38 ▲

PEZZI SPECIALI trims - pieces speciales - formstücke - СОБИЕЭЛЕМЕНТЫ

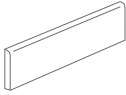

battiscopa
7,5x30 (3"x12")
6434771 almond
6434761 forest
6434781 multicolor
6434751 gold
7671181 grey
7671191 black

12 ▲ 32 ☐

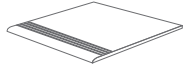

gradino step
30x30 (12"x12")
6434731 almond
6434721 forest
6434741 multicolor
6434711 gold
7671201 grey
7671211 black

30 ▲ 11 ☐

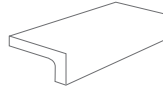

elemento elle pressa
15x30x3,5 (6"x12"x1,4")
7671155 almond
7671156 forest
7671157 multicolor
7671154 gold
7671153 grey
7671152 black

44 ▲ 8 ☐

IMBALLI packing - emballages - verpackung - УПАКОВКА

F.TO NOMINALE / NOMINAL SIZE	mm.	PCS / BOX	M2 / BOX	BOX / PLT	M2 / PLT	KG. / PLT
30x60	9	7	1,26	40	50,4	989
29,7x59,5 rett.	9	7	1,24	40	49,6	973
45x45	9	7	1,42	26	36,92	709
44,5x44,5 rett.	9	7	1,39	26	36,14	694
30x30	8	13	1,17	48	56,16	960
29,7x29,7 rett.	8	11	0,97	48	46,56	912
15x15	8	32	0,72	56	40,32	840
14,8x14,8 rett.	9	32	0,70	56	39,2	728
30x30 muretto	9	11	1	30	30	570
30x30 mosaico	9	11	1	30	30	570



galapagos | stone effect

avorio



dorato



terra

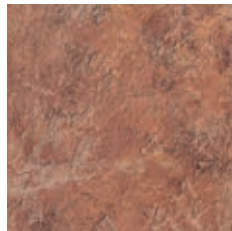

verde

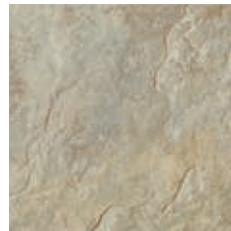

SUPERFICI
SURFACE
SURFACE
OBERFLÄCHE
ПОВЕРХНОСТИ

Naturale
Natural
Naturelle
Matt
Натуральный

antracite

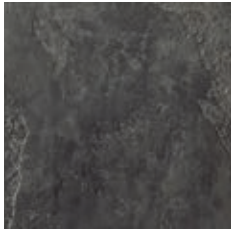

30x30 (12"x12") 62 ●
7634190 avorio
7634230 dorato
7634200 terra
7634210 verde
7634220 antracite



15x30 (6"x12") 62 ●
7615001 avorio
7615011 dorato
7615021 terra
7615081 verde
7615091 antracite

Grip
Grip
Grip
Grip
Grip

mosaico 5x5 (2"x2") 124 ●



30x30 (12"x12")
7634241



grip 62 ●
7666971 avorio grip
7667011 dorato grip
7667021 terra grip
7666981 verde grip
7666991 antracite grip



15x15 (6"x6") 62 ●
7697000 avorio
7697010 dorato
7697020 terra
7697030 verde
7695990 antracite



FUGA >3 mm



DIN 51130
R9
PER NATURALE



DIN 51130
R11
PER GRIP



DIN 51097
A+B
PER GRIP

PEZZI SPECIALI trims - pieces speciales - formstücke - СОБЫЕЭЛЕМЕНТЫ



battiscopa
7,5x30 (3"x12")
7634500 antracite
7634530 avorio
7634540 dorato
7634510 terra
7634520 verde

12 ▲ 32 ☐

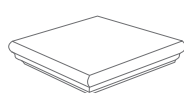

*** gradone angolare**
30x30 (12"x12")
7658820 antracite
7658790 avorio
7658830 dorato
7658800 terra
7658810 verde

93 ▲ 2 ☐



*** gradone**
30x30 (12"x12")
7658770 antracite
7658740 avorio
7658780 dorato
7658750 terra
7658760 verde

66 ▲ 6 ☐

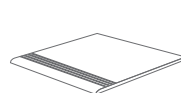

step
30x30 (12"x12")
7634440 antracite
7634450 avorio
7634460 dorato
7634470 terra
7634480 verde

30 ▲ 15 ☐

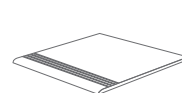

step grip
30x30 (12"x12")
7634442 antracite grip
7634452 avorio grip
7634462 dorato grip
7634472 terra grip
7634482 verde grip

30 ▲ 15 ☐

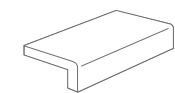

! elemento elle
15x30x4 (6"x12"x1,6")
7634580 antracite
7634570 verde

42 ▲ 8 ☐

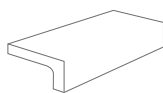

! elemento elle pressa
15x30x3,5 (6"x12"x1,4")
7637679 avorio
7637689 dorato
7637699 terra

44 ▲ 8 ☐

! AVVERTENZA: SE ABBINATO AL FORMATO 15x15 UTILIZZARE SEMPRE UNA POSA DIAGONALE
CAUTION: IF INSTALLED WITH SIZE 15x15, ALWAYS INSTALL DIAGONALLY
AVERTISSEMENT: SI EN COMBINAISON AVEC LE 15x15 UTILISER TOUJOURS UNE POSE EN DIAGONAL
ACHTUNG: WENN DER SCHENKEL MIT DEM FORMAT 15x15 KOMBINIERT WIRD, WIRD EINE DIAGONALVERLEGUNG NOTWENDIG
ВНИМАНИЕ! ПРЕДУПРЕЖДЕНИЕ: В СОЧЕТАНИИ С РАЗМЕРОМ 15x15 ВСЕГДА ИСПОЛЬЗОВАТЬ ДИАГОНАЛЬНЫЙ ТИП УКЛАДКИ

IMBALLI packing - emballages - verpackung - УПАКОВКА

F.TO NOMINALE / NOMINAL SIZE	mm.	PCS / BOX	M2 / BOX	BOX / PLT	M2 / PLT	KG. / PLT
30x30	8	13	1,17	48	56,16	960
15x30	8	23	1,04	75	78	1239
15x15	8	46	1,04	75	78	1239
30x30 Mosaico	8	11	1	-	-	-



kaleido | stone effect

COLORI

colours - couleurs - farbe - ЦВѢТА



avorio



bianco



beige



cenere

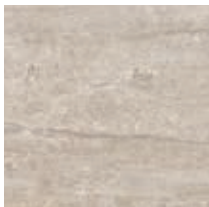

mandorla



grigio

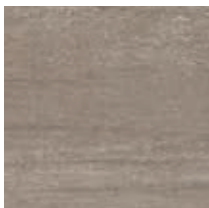

cappuccino

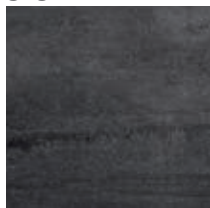

nero

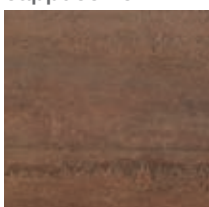

marrone

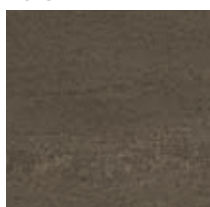

mokka

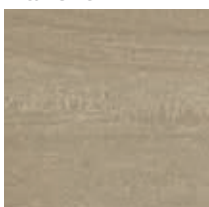

fango

> pag. 60

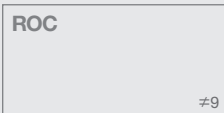

30x60 (12"x24") NAT.
29,7x59,5 (12"x24") RETT.



30x30 (12"x12") NAT. $\neq 8$
29,7x29,7 (12"x12") RETT. $\neq 9$

FORMATI

sizes - formats - format - ФОРМАТЫ

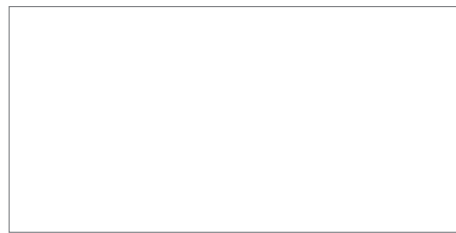

60x120 (24"x47") RETTIFICATO

$\neq 10$

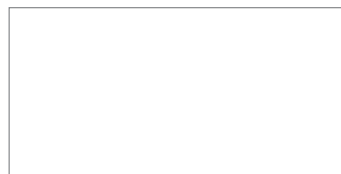

45x90 (18"x36") RETTIFICATO

$\neq 10$



22,5x90 (9"x36") RETTIFICATO

$\neq 10$



59,5x59,5 (24"x24") RETTIFICATO

$\neq 10$



14,8x59,5 (6"x24") RETTIFICATO

$\neq 9$



30x60 (12"x24") NATURALE
29,7x59,5 (12"x24") RETTIFICATO

$\neq 9$



45x45 (18"x18") NATURALE
44,5x44,5 (18"x18") RETTIFICATO

$\neq 9$



30x30 (12"x12") NATURALE $\neq 8$
29,7x29,7 (12"x12") RETTIFICATO $\neq 9$



15x15 (6"x6") NATURALE

$\neq 8$

SUPERFICI
SURFACE
SURFACE
OBERFLACHE
ПОВЕРХНОСТИ

Naturale

Natural
Naturelle
Matt

Натуральный

Lappato

Semi-Polished

Lappato

Halbpoliert

Полуполированный



POSA 1/4



FUGA 2 mm
PER RETTIFICATO



FUGA >3 mm
PER NATURALE

kaleido | stone effect

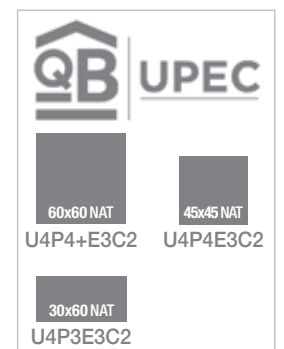

grigio



kaleido | stone effect



60x120 (24"x48")

7663039 nat. rett.
7663079 lapp. rett.

91 ●
99 ●



45x90 (18"x36")

7655495 nat. rett.
7655525 lapp. rett.

85 ●
93 ●



22,5x90 (9"x36")

7659395 nat. rett.
7659325 lapp. rett.

85 ●
93 ●



30x60 (12"x24")

7665351 nat.
29,7x59,5 (12"x24")
7665411 nat. rett.
7665471 lapp. rett.

68 ●
78 ●
86 ●

mosaico 5x5 (2"x2") 124 ●



30x30 (12"x12")
7665821 nat.
7673161 lapp.

muretto 2,5x5 (1"x2") 139 ●



29,7x29,7 (12"x12")
7666081 ce/gr/ne



14,8x59,5 (6"x24")

7669513 nat. rett.
7669531 lapp. rett.

87 ●
95 ●

listellato 131 ●



30x60 (12"x24")
7670441 nat.
7670451 lapp.



59,5x59,5 (24"x24")

7683315 nat. rett.
7683345 lapp. rett.

81 ●
88 ●



45x45 (18"x18")

7653245 nat.
44,5x44,5 (18"x18")
7663355 nat. rett.
7653265 lapp. rett.

62 ●
76 ●
85 ●

fascia joint 21 ▲



7,5x30 (3"x12")
7679251 joint cold (ce/gr/ne/bi)



30x30 (12"x12")

7666041 nat.
29,7x29,7 (12"x12")
7665531 nat. rett.
7665611 lapp. rett.

62 ●
78 ●
86 ●



15x15 (6"x6")

7670721 nat. 62 ●

cenere



kaleido



60x120 (24"x48")
 7663059 nat. rett. 91 ●
 7663099 lapp. rett. 99 ●



45x90 (18"x36")
 7656505 nat. rett. 85 ●
 7656515 lapp. rett. 93 ●



22,5x90 (9"x36")
 7659385 nat. rett. 85 ●
 7659315 lapp. rett. 93 ●



30x60 (12"x24")
 7665341 nat. 68 ●
 29,7x59,5 (12"x24")
 7665401 nat. rett. 78 ●
 7665461 lapp. rett. 86 ●



14,8x59,5 (6"x24")
 7669503 nat. rett. 87 ●
 7669521 lapp. rett. 95 ●

mosaico 5x5 (2"x2") 124 ●



30x30 (12"x12")
 7665841 nat.
 7673151 lapp.

muretto 2,5x5 (1"x2") 139 ●



29,7x29,7 (12"x12")
 7666081 ce/gr/ne

listellato 131 ●



30x60 (12"x24")
 7670461 nat.
 7670471 lapp.

fascia joint 21 ▲



7,5x30 (3"x12")
 7679251 joint cold (ce/gr/ne/bi)



59,5x59,5 (24"x24")
 7683555 nat. rett. 81 ●
 7683585 lapp. rett. 88 ●



45x45 (18"x18")
 7653065 nat. 62 ●
 44,5x44,5 (18"x18")
 7653275 nat. rett. 76 ●
 7661806 lapp. rett. 85 ●



30x30 (12"x12")
 7666031 nat. 62 ●
 29,7x29,7 (12"x12")
 7665521 nat. rett. 78 ●
 7665601 lapp. rett. 86 ●



15x15 (6"x6")
 7670711 nat. 62 ●

kaleido | stone effect

bianco



kaleido | stone effect



60x120 (24"x47")

7663069 nat. rett.
7663109 lapp. rett.

91 ●
99 ●



45x90 (18"x36")

7656535 nat. rett.
7657245 lapp. rett.

85 ●
93 ●



22,5x90 (9"x36")

7659425 nat. rett.
7659355 lapp. rett.

85 ●
93 ●



30x60 (12"x24")

7667421 nat.
29,7x59,5 (12"x24")
7667431 nat. rett.
7667441 lapp. rett.

68 ●
78 ●
86 ●

mosaico 5x5 (2"x2") 124 ●

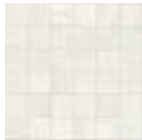

30x30 (12"x12")
7667451 nat.
7673141 lapp.

muretto 2,5x5 (1"x2") 139 ●



29,7x29,7 (12"x12")
7666081 ce/gr/ne



14,8x59,5 (6"x24")

7669562 nat. rett.
7669561 lapp. rett.

87 ●
95 ●

listellato 131 ●



30x60 (12"x24")
7670561 nat.
7670571 lapp.



59,5x59,5 (24"x24")

7683565 nat. rett.
7683595 lapp. rett.

81 ●
88 ●



45x45 (18"x18")

7653115 nat.
44,5x44,5 (18"x18")
7663325 nat. rett.
7661825 lapp. rett.

62 ●
76 ●
85 ●

fascia joint 21 ▲



7,5x30 (3"x12")
7679251 joint cold (ce/gr/ne/bi)



30x30 (12"x12")

7666091 nat.
29,7x29,7 (12"x12")
7669491 nat. rett.
7666101 lapp. rett.

62 ●
78 ●
86 ●



15x15 (6"x6")

7671371 nat. 62 ●

nero



kaleido

kaleido | stone effect

mosaico 5x5 (2"x2") 124 ●



30x30 (12"x12")
7665851 nat.
7673181 lapp.

muretto 2,5x5 (1"x2") 139 ●



29,7x29,7 (12"x12")
7666081 ce/gr/ne

listellato 131 ●



30x60 (12"x24")
7670481 nat.
7670491 lapp.

fascia joint 21 ▲



7,5x30 (3"x12")
7679251 joint cold (ce/gr/ne/bi)

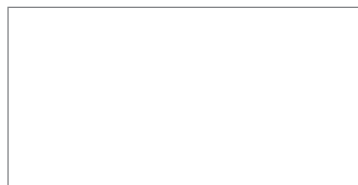

60x120 (24"x47")
7663049 nat. rett. 91 ●
7663089 lapp. rett. 99 ●



45x90 (18"x36")
7655505 nat. rett. 85 ●
7655535 lapp. rett. 93 ●



22,5x90 (9"x36")
7659415 nat. rett. 85 ●
7659345 lapp. rett. 93 ●



30x60 (12"x24")
7665361 nat. 68 ●
29,7x59,5 (12"x24")
7665421 nat. rett. 78 ●
7665481 lapp. rett. 86 ●



14,8x59,5 (6"x24")
7671411 nat. rett. 87 ●
7669551 lapp. rett. 95 ●



59,5x59,5 (24"x24")
7683325 nat. rett. 81 ●
7683355 lapp. rett. 88 ●



45x45 (18"x18")
7653235 nat. 62 ●
44,5x44,5 (18"x18")
7663345 nat. rett. 76 ●
7653255 lapp. rett. 85 ●



30x30 (12"x12")
7666061 nat. 62 ●
29,7x29,7 (12"x12")
7665541 nat. rett. 78 ●
7665621 lapp. rett. 86 ●



15x15 (6"x6")
7670701 nat. 62 ●

cappuccino



kaleido | stone effect

mosaico 5x5 (2"x2") 124 ●



30x30 (12"x12")
7674811 nat.
7674821 lapp.

muretto 2,5x5 (1"x2") 139 ●



29,7x29,7 (12"x12")
7678541 av/ma/ca

listellato 131 ●



30x60 (12"x24")
7674831 nat.
7674841 lapp.

fascia joint 21 ▲



7,5x30 (3"x12")
7679241 joint warn (mo/ca/ma/av)

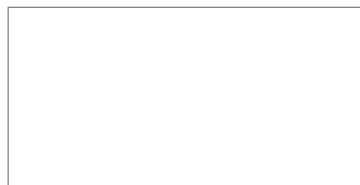

60x120 (24"x47")
7664439 nat. rett.
7664569 lapp. rett.

91 ●
99 ●



45x90 (18"x36")
7661645 nat. rett.
7661675 lapp. rett.

85 ●
93 ●



22,5x90 (9"x36")
7661735 nat. rett.
7661755 lapp. rett.

85 ●
93 ●



30x60 (12"x24")
7674701 nat.
29,7x59,5 (12"x24")
7674711 nat. rett.
7674721 lapp. rett.

68 ●
78 ●
86 ●



14,8x59,5 (6"x24")
7674731 nat. rett.
7674741 lapp. rett.

87 ●
95 ●



59,5x59,5 (24"x24")
7685355 nat. rett.
7685375 lapp. rett.

81 ●
88 ●



45x45 (18"x18")
7653095 nat.
44,5x44,5 (18"x18")
7653305 nat. rett.
7661785 lapp. rett.

62 ●
76 ●
85 ●



30x30 (12"x12")
7666631 nat.
29,7x29,7 (12"x12")
7674751 nat. rett.
7674761 lapp. rett.

62 ●
78 ●
86 ●



15x15 (6"x6")
7697361 nat. 62 ●

marrone



kaleido



60x120 (24"x47")
 7663119 nat. rett. 91 ●
 7663129 lapp. rett. 99 ●



45x90 (18"x36")
 7657265 nat. rett. 85 ●
 7657275 lapp. rett. 93 ●



22,5x90 (9"x36")
 7659405 nat. rett. 85 ●
 7659335 lapp. rett. 93 ●



30x60 (12"x24")
 7665381 nat. 68 ●
 29,7x59,5 (12"x24")
 7665441 nat. rett. 78 ●
 7665501 lapp. rett. 86 ●

mosaico 5x5 (2"x2") 124 ●

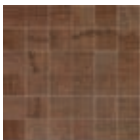

30x30 (12"x12")
 7665811 nat.
 7673171 lapp.

muretto 2,5x5 (1"x2") 139 ●



29,7x29,7 (12"x12")
 7666071 av/bg/ma



14,8x59,5 (6"x24")
 7671431 nat. rett. 87 ●
 7669541 lapp. rett. 95 ●

listellato 131 ●



30x60 (12"x24")
 7670541 nat.
 7670551 lapp.



59,5x59,5 (24"x24")
 7683575 nat. rett. 81 ●
 7683605 lapp. rett. 88 ●



45x45 (18"x18")
 7653225 nat. 62 ●
 44,5x44,5 (18"x18")
 7663335 nat. rett. 76 ●
 7661815 lapp. rett. 85 ●

fascia joint 21 ▲



7,5x30 (3"x12")
 7679241 joint warn (mo/ca/ma/av)



30x30 (12"x12")
 7666051 nat. 62 ●
 29,7x29,7 (12"x12")
 7665571 nat. rett. 78 ●
 7665641 lapp. rett. 86 ●



15x15 (6"x6")
 7671401 nat. 62 ●

kaleido | stone effect

mandorla



kaleido | stone effect

mosaico 5x5 (2"x2") 124 ●



30x30 (12"x12")
7674931 nat.
7674941 lapp.

muretto 2,5x5 (1"x2") 139 ●



29,7x29,7 (12"x12")
7678541 av/ma/ca

listellato 131 ●



30x60 (12"x24")
7674951 nat.
7674961 lapp.

fascia joint 21 ▲



7,5x30 (3"x12")
7679241 joint warn (mo/ca/ma/av)



60x120 (24"x47")

7681409 nat. rett.
7681419 lapp. rett.

91 ●
99 ●



45x90 (18"x36")

7661665 nat. rett.
7661685 lapp. rett.

85 ●
93 ●



22,5x90 (9"x36")

7661745 nat. rett.
7661765 lapp. rett.

85 ●
93 ●



30x60 (12"x24")

7674861 nat.
29,7x59,5 (12"x24")
7674871 nat. rett.
7674881 lapp. rett.

68 ●
78 ●
86 ●



14,8x59,5 (6"x24")

7674891 nat. rett.
7674901 lapp. rett.

87 ●
95 ●



59,5x59,5 (24"x24")

7685365 nat. rett.
7685385 lapp. rett.

81 ●
88 ●



45x45 (18"x18")

7653085 nat.
44,5x44,5 (18"x18")
7653295 nat. rett.
7661795 lapp. rett.

62 ●
76 ●
85 ●



30x30 (12"x12")

7666641 nat.
30x30 (12"x12")
7674911 nat. rett.
7674921 lapp. rett.

62 ●
78 ●
86 ●



15x15 (6"x6")

7697371 nat. 62 ●

avorio



kaleido



60x120 (24"x47")
 7683214 nat. rett. 91 ●
 7683213 lapp. rett. 99 ●



45x90 (18"x36")
 7655565 nat. rett. 85 ●
 7655575 lapp. rett. 93 ●



22,5x90 (9"x36")
 7659365 nat. rett. 85 ●
 7659295 lapp. rett. 93 ●



30x60 (12"x24")
 7665331 nat. 68 ●
 29,7x59,5 (12"x24")
 7665391 nat. rett. 78 ●
 7665451 lapp. rett. 86 ●



14,8x59,5 (6"x24")
 7669502 nat. rett. 87 ●
 7669501 lapp. rett. 95 ●



59,5x59,5 (24"x24")
 7683385 nat. rett. 81 ●
 7683395 lapp. rett. 88 ●



45x45 (18"x18")
 7653105 nat. 62 ●
 44,5x44,5 (18"x18")
 7653315 nat. rett. 76 ●
 7661805 lapp. rett. 85 ●



30x30 (12"x12")
 7666011 nat. 62 ●
 29,7x29,7 (12"x12")
 7665511 nat. rett. 78 ●
 7665591 lapp. rett. 86 ●



15x15 (6"x6")
 7671381 nat. 62 ●

mosaico 5x5 (2"x2") 124 ●

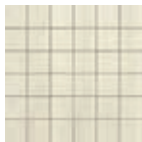

30x30 (12"x12")
 7665801 nat.
 7673121 lapp.

muretto 2,5x5 (1"x2") 139 ●



29,7x29,7 (12"x12")
 7666071 av/bg/ma



29,7x29,7 (12"x12")
 7678541 av/ma/ca

listellato 131 ●



30x60 (12"x24")
 7670501 nat.
 7670511 lapp.

fascia joint 21 ▲



7,5x30 (3"x12")
 7679241 joint warn (mo/ca/ma/av)

beige



kaleido | stone effect

mosaico 5x5 (2"x2") 124 ●

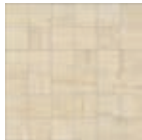

30x30 (12"x12")
7665831 nat.
7673131 lapp.

muretto 2,5x5 (1"x2") 139 ●



29,7x29,7 (12"x12")
7666071 av/bg/ma

listellato 131 ●



30x60 (12"x24")
7670521 nat.
7670531 lapp.

fascia joint 21 ▲



7,5x30 (3"x12")
7679241 joint warn (mo/ca/ma/av)



60x120 (24"x47")
7683215 nat. rett.
7683225 lapp. rett.

91 ●
99 ●



45x90 (18"x36")
7655515 nat. rett.
7655545 lapp. rett.

85 ●
93 ●



22,5x90 (9"x36")
7659375 nat. rett.
7659305 lapp. rett.

85 ●
93 ●



30x60 (12"x24")
7665371 nat.
29,7x59,5 (12"x24")
7665431 nat. rett.
7665491 lapp. rett.

68 ●
78 ●
86 ●



14,8x59,5 (6"x24")
7671421 nat. rett.
7669511 lapp. rett.

87 ●
95 ●



59,5x59,5 (24"x24")
7683335 nat. rett.
7683365 lapp. rett.

81 ●
88 ●



45x45 (18"x18")
7653075 nat.
44,5x44,5 (18"x18")
7653285 nat. rett.
7661775 lapp. rett.

62 ●
76 ●
85 ●



30x30 (12"x12")
7666021 nat.
29,7x29,7 (12"x12")
7665561 nat. rett.
7665631 lapp. rett.

62 ●
78 ●
86 ●



15x15 (6"x6")
7671391 nat.

62 ●

mokka



mosaico 5x5 (2"x2") 124 ● listellato 131 ●

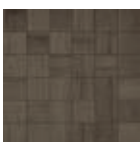

30x30 (12"x12")
7679071 nat.
7673122 lapp.

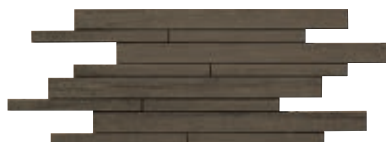

30x60 (12"x24")
7679201 nat.
7679221 lapp.

fascia joint

21 ▲



7,5x30 (3"x12")
7679241 joint warn (mo/ca/ma/av)

kaleido



45x90 (18"x36")
7600675 nat. rett. 85 ●
7600685 lapp. rett. 93 ●



22,5x90 (9"x36")
7600695 nat. rett. 85 ●
7600705 lapp. rett. 93 ●



30x60 (12"x24")
7679011 nat. 68 ●
29,7x59,5 (12"x24")
7679031 nat. rett. 78 ●
7679051 lapp. rett. 86 ●



14,8x59,5 (6"x24")
7674732 nat. rett. 87 ●



15x15 (6"x6")
7666941 nat. 62 ●



59,5x59,5 (24"x24")
7690675 nat. rett. 81 ●
7690685 lapp. rett. 88 ●



30x30 (12"x12")
7666931 nat. 62 ●
29,7x29,7 (12"x12")
7644912 nat. rett. 78 ●

kaleido | stone effect

fango



mosaico 5x5 (2"x2") 124 ●



30x30 (12"x12")
7679061 nat.

listellato 131 ●



30x60 (12"x24")
7679211 nat.
7679231 lapp.



30x60 (12"x24")
7679001 nat. 68 ●
29,7x59,5 (12"x24")
7679021 nat. rett. 78 ●
7679041 lapp. rett. 86 ●



30x30 (12"x12")
7666951 nat. 62 ●



15x15 (6"x6")
7666961 nat. 62 ●

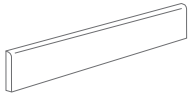

battiscopa naturale

- 7,5x60** (3"x24")
 7669431 bianco nat.
 7669321 cenere nat.
 7669331 grigio nat.
 7669421 nero nat.
 7669301 avorio nat.
 7669311 beige nat.
 7669411 marrone nat.
 7674851 mandorla nat.
 7674571 cappuccino nat.
 7679101 mokka nat.
 7679111 fango nat.

24 ▲ 14 ◻

battiscopa naturale rett.

- 7,5x59,5** (3"x24")
 7669291 bianco nat. rett.
 7669171 cenere nat. rett.
 7669181 grigio nat. rett.
 7669191 nero nat. rett.
 7669201 avorio nat. rett.
 7665864 beige nat. rett.
 7669211 marrone nat. rett.
 7675011 mandorla nat. rett.
 7675001 cappuccino nat. rett.
 7679081 mokka nat. rett.
 7679091 fango nat. rett.

24 ▲ 14 ◻

battiscopa lappato rett.

- 7,5x59,5** (3"x24")
 7675061 bianco lapp. rett.
 7675071 cenere lapp. rett.
 7675081 grigio lapp. rett.
 7675091 nero lapp. rett.
 7675101 avorio lapp. rett.
 7675111 beige lapp. rett.
 7675121 marrone lapp. rett.
 7675141 mandorla lapp. rett.
 7675131 cappuccino lapp. rett.

24 ▲ 14 ◻

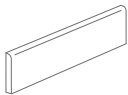

battiscopa naturale

- 7,5x30** (3"x12")
 7667491 bianco nat.
 7665881 cenere nat.
 7665891 grigio nat.
 7666001 nero nat.
 7665861 avorio nat.
 7665871 beige nat.
 7665991 marrone nat.
 7674541 mandorla nat.
 7674531 cappuccino nat.

12 ▲ 32 ◻

battiscopa naturale rett.

- 7,5x29,7** (3"x12")
 7667501 bianco nat. rett.
 7665721 cenere nat. rett.
 7665731 grigio nat. rett.
 7665741 nero nat. rett.
 7665711 avorio nat. rett.
 7665751 beige nat. rett.
 7665761 marrone nat. rett.
 7674561 mandorla nat. rett.
 7674551 cappuccino nat. rett.

12 ▲ 32 ◻

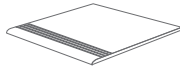

gradino step naturale

- 30x30** (12"x12")
 7669461 bianco nat.
 7637511 cenere nat.
 7637521 grigio nat.
 7637531 nero nat.
 7637501 avorio nat.
 7638001 beige nat.
 7637541 marrone nat.
 7674171 mandorla nat.
 7674161 cappuccino nat.

30 ▲ 11 ◻

gradino step naturale rett.

- 29,7x29,7** (12"x12")
 7669471 bianco nat. rett.
 7637571 cenere nat. rett.
 7637581 grigio nat. rett.
 7637591 nero nat. rett.
 7637561 avorio nat. rett.
 7637551 beige nat. rett.
 7637601 marrone nat. rett.
 7674191 mandorla nat. rett.
 7674181 cappuccino nat. rett.

30 ▲ 11 ◻

gradino step lappato rett.

- 29,7x29,7** (12"x12")
 7669481 bianco lapp. rett.
 7637631 cenere lapp. rett.
 7637641 grigio lapp. rett.
 7637651 nero lapp. rett.
 7637621 avorio lapp. rett.
 7637611 beige lapp. rett.
 7637661 marrone lapp. rett.
 7674461 mandorla lapp. rett.
 7674451 cappuccino lapp. rett.

35 ▲ 11 ◻

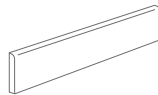

battiscopa naturale

- 9x45** (3,5"x18")
 7664525 bianco nat.
 7664545 cenere nat.
 7664555 grigio nat.
 7664685 nero nat.
 7664505 avorio nat.
 7664515 beige nat.
 7664605 marrone nat.
 7664565 mandorla nat.
 7664535 cappuccino nat.

18 ▲ 12 ◻

battiscopa naturale rett.

- 9x44,5** (3,5"x18")
 7664526 bianco nat. rett.
 7664536 cappuccino nat. rett.

18 ▲ 12 ◻

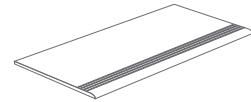

gradino step naturale

- 30x60** (12"x24")
 7667461 bianco nat.
 7666769 cenere nat.
 7666789 grigio nat.
 7666799 nero nat.
 7666779 avorio nat.
 7666809 beige nat.
 7666819 marrone nat.
 7674481 mandorla nat.
 7674471 cappuccino nat.
 7667463 mokka nat.

48 ▲ 7 ◻

gradino step naturale rett.

- 29,7x59,5** (12"x24")
 7667471 bianco nat. rett.
 7666649 cenere nat. rett.
 7666669 grigio nat. rett.
 7666679 nero nat. rett.
 7666659 avorio nat. rett.
 7666689 beige nat. rett.
 7666699 marrone nat. rett.
 7674451 mandorla nat. rett.
 7674491 cappuccino nat. rett.

48 ▲ 7 ◻

gradino step lappato rett.

- 29,7x59,5** (12"x24")
 7667481 bianco lapp. rett.
 7666709 cenere lapp. rett.
 7666729 grigio lapp. rett.
 7666739 nero lapp. rett.
 7666719 avorio lapp. rett.
 7666749 beige lapp. rett.
 7666759 marrone lapp. rett.
 7674521 mandorla lapp. rett.
 7674511 cappuccino lapp. rett.

53 ▲ 7 ◻

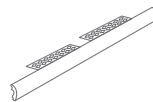

*** toreello gradino nat. rett.**

- 4x59,5** (1,5"x24")
 7667519 bianco rett.
 7666899 cenere rett.
 7666909 grigio rett.
 7666919 nero rett.
 7666889 avorio rett.
 7666929 beige rett.
 7666939 marrone rett.
 7675039 mandorla rett.
 7675029 cappuccino rett.

99 ▲ 4 ◻

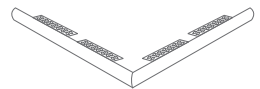

*** toreello set angolare nat. rett.**

- 4x59,5** (1,5"x24")
 7667529 bianco rett.
 7666959 cenere rett.
 7666969 grigio rett.
 7666979 nero rett.
 7666949 avorio rett.
 7666989 beige rett.
 7666999 marrone rett.
 7675059 mandorla rett.
 7675049 cappuccino rett.

126 ▲ 2 set ◻

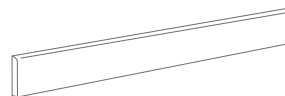

battiscopa rett.

- 10x120** (4"x47")
 7683221 bianco rett.
 7683222 cenere rett.
 7683223 grigio rett.
 7683228 nero rett.
 7683217 avorio rett.







48 ▲ 4 ◻

- 7683218 beige rett.
 7683227 marrone rett.
 7683224 mandorla rett.
 7683220 cappuccino rett.



bianco, cenere grigio 22,5x90 (9"x36")

IMBALLI packing - emballages - verpackung - УПАКОВКА

F.TO NOMINALE / NOMINAL SIZE	 mm.	 PCS / BOX	 M2 / BOX	 BOX / PLT	 M2 / PLT	 KG. / PLT
60x120 rett.	10	2	1,44	36	51,84	1152
45x90 rett.	10	3	1,215	30	36,45	840
22,5x90 rett.	10	6	1,215	36	43,74	972
59,5x59,5 rett.	10	3	1,062	40	42,48	960
30x60	9	7	1,26	40	50,4	989
29,7x59,5 rett.	9	7	1,24	40	49,6	973
14,8x59,5 rett.	9	14	1,23	40	49,2	965
45x45	9	7	1,42	26	36,92	709
44,5x44,5 rett.	9	7	1,39	26	36,14	694
30x30	8	13	1,17	48	56,16	960
29,7x29,7 rett.	9	11	0,97	48	46,56	912
15x15	8	46	1,04	75	78	1239
30x30 mosaico	9	11	1	-	-	-
29,7x29,7 muretto	9	11	1	-	-	-
30x60 listellato	9	4	0,72	-	-	-



kaleido roc | stone effect

kaleido roc

COLORI

colours - couleurs - farbe - ЦВЕТА



bianco roc



cenere roc

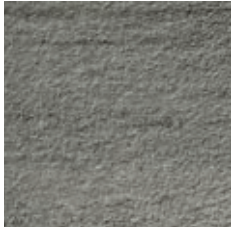

grigio roc



nero roc

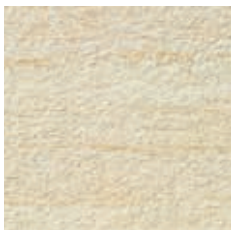

beige roc



cappuccino roc



marrone roc

FORMATI

sizes - formats - format - ФОРМАТЫ



≠9

30x60 (12"x24") NATURALE

29,7x59,5 (12"x24") RETTIFICATO



30x30 (12"x12") NATURALE ≠8

29,7x29,7 (12"x12") RETTIFICATO ≠9

GM

V3



POSA 1/4



FUGA >3 mm



DIN 51130
R11



DIN 51097
A+B+C

kaleido roc | stone effect

bianco roc



beige roc



30x60 (12"x24")

naturale 68 ●

7672275 bianco roc

7672265 cenere roc

7672245 grigio roc

7677735 nero roc

7672255 beige roc

7677885 cappuccino roc

cenere roc



cappuccino roc



29,7x59,5 (12"x24")

rettificato 78 ●

7672315 bianco roc rett.

7672305 cenere roc rett.

7672285 grigio roc rett.

7672295 beige roc rett.

7672296 cappuccino roc rett.



30x30 (12"x12")

naturale 62 ●

7666691 bianco roc

7666681 cenere roc

7666671 grigio roc

7666661 nero roc

7666701 marrone roc

grigio roc

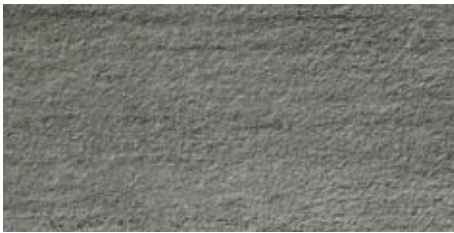

marrone roc

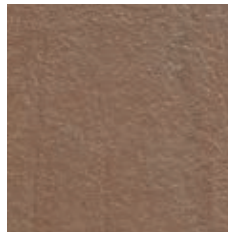

29,7x29,7 (12"x12")

rettificato 78 ●

7665512 bianco roc rett.

7665522 cenere roc rett.

7672286 grigio roc rett.

nero roc



mosaico 5x5 (2"x2") 124 ●



30x30 (12"x12")
7666077 bianco roc

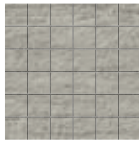

30x30 (12"x12")
7665878 cenere roc

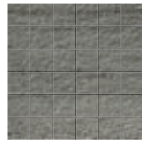

30x30 (12"x12")
7665823 grigio roc



30x30 (12"x12")
7665879 nero roc



30x30 (12"x12")
7666076 cappuccino roc



30x30 (12"x12")
7666075 beige roc

muretto 2,5x5 (1"x2") 139 ●



30x30 (12"x12")
7666073 Bi/Bg/Ma roc

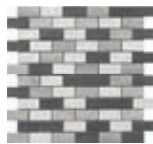

30x30 (12"x12")
7666074 Ce/Gr/Ne roc

PEZZI SPECIALI trims - pieces speciales - formstücke - СОБИЕЭЛЕМЕНТЫ



battiscopa
7,5x30 (3"x12")
7672325 grigio roc
7672335 beige roc
7672345 cenere roc
7672355 bianco roc
7672326 cappuccino roc
7672327 nero roc
12 ▲ 32 ◻

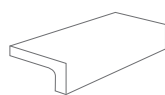

elemento elle pressa
15x30x3,5 (6"x12"x1,4")
7675009 grigio roc
7674979 beige roc
7674999 cenere roc
7674989 bianco roc
7675089 cappuccino roc
7675019 marrone roc
7655030 nero roc
44 ▲ 8 ◻

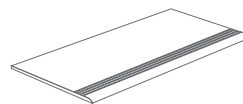

gradino step
30x60 (12"x24")
7672365 grigio roc
7672375 beige roc
7672385 cenere roc
7672395 bianco roc
7672396 cappuccino roc
7677736 nero roc
48 ▲ 7 ◻

IMBALLI packing - emballages - verpackung - УПАКОВКА

F.TO NOMINALE / NOMINAL SIZE	mm.	PCS / BOX	M2 / BOX	BOX / PLT	M2 / PLT	KG. / PLT
30x60	9	7	1,26	40	50,4	989
29,7x59,5 rett.	9	7	1,24	40	49,6	973
30x30	8	13	1,17	48	56,16	1020
29,7x29,7 rett.	9	11	0,97	48	46,56	964,80
30x30 mosaico-muretto	9	11	1	-	-	-



COLORI

colours - couleurs - farbe - ЦВЕТА



beige

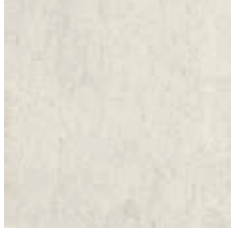

bianco

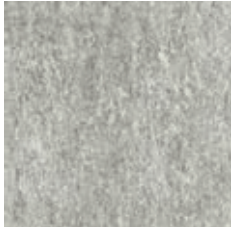

grigio

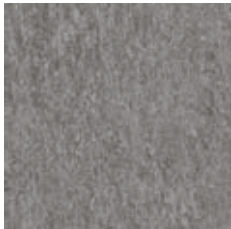

fumo



nero

FORMATI

sizes - formats - format - ФОРМАТЫ



≠9

30x60 (12"x24") NATURALE

29,7x59,5 (12"x24") RETTIFICATO



30x30 (12"x12") NATURALE ≠8

29,7x29,7 (12"x12") RETTIFICATO ≠9



15x30 (6"x12") NATURALE ≠8

14,8x29,7 (6"x12") RETTIFICATO ≠9

> pag. 68

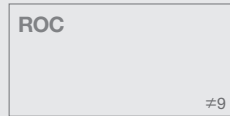

≠9

30x60 (12"x24") NAT.

29,7x59,5 (12"x24") RETT.

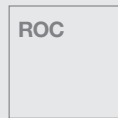

30x30 (12"x12") NAT. ≠8

29,7x29,7 (12"x12") RETT. ≠9



15x30 (6"x12") NAT. ≠8

14,8x29,7 (6"x12") RETT. ≠9



15x15 (6"x6") NAT. ≠8

14,8x14,8 (6"x6") RETT. ≠9

SUPERFICI

SURFACE

SURFACE

OBERFLACHE

ПОВЕРХНОСТИ

Naturale

Natural

Naturelle

Matt

Натуральный

Lappato

Semi-Polished

Lappato

Halbpoliert

Полуполированный



POSA 1/4



FUGA 2 mm
PER RETTIFICATO



FUGA >3 mm
PER NATURALE



DIN 51130

R10

PER NATURALE



DIN 51130

R9

PER LAPPATO

bianco



30x60 (12"x24")

naturale

- 7667581 bianco
- 7667621 beige
- 7667591 grigio
- 7667601 fumo
- 7667611 nero

68 ●



15x30 (6"x12")

naturale

- 7666111 bianco
- 7666151 beige
- 7666121 grigio
- 7666131 fumo
- 7666141 nero

62 ●

beige



29,7x59,5 (12"x24")

rettificato

- 7667631 bianco nat. rett.
- 7667681 beige nat. rett.
- 7667651 grigio nat. rett.
- 7667661 fumo nat. rett.
- 7667671 nero nat. rett.

78 ●

14,8x29,7 (6"x12")

rettificato

- 7667741 bianco nat. rett.
- 7667781 beige nat. rett.
- 7667751 grigio nat. rett.
- 7667761 fumo nat. rett.
- 7667771 nero nat. rett.

83 ●

lappato rettificato

86 ●

- 7667791 bianco lapp. rett.
- 7667831 beige lapp. rett.
- 7667801 grigio lapp. rett.
- 7667811 fumo lapp. rett.
- 7667821 nero lapp. rett.

lappato rettificato

91 ●

- 7667891 bianco lapp. rett.
- 7667931 beige lapp. rett.
- 7667901 grigio lapp. rett.
- 7667911 fumo lapp. rett.
- 7667921 nero lapp. rett.

grigio

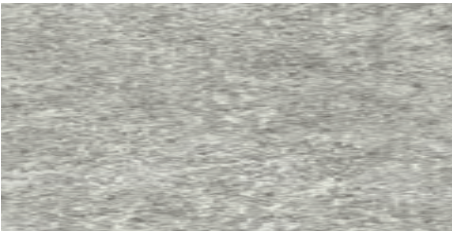

30x30 (12"x12")

naturale

- 7666891 bianco
- 7666881 beige
- 7666821 grigio
- 7666901 fumo
- 7666911 nero

62 ●

29,7x29,7 (12"x12")

rettificato

- 7667691 bianco nat. rett.
- 7667731 beige nat. rett.
- 7667701 grigio nat. rett.
- 7667711 fumo nat. rett.
- 7667721 nero nat. rett.

78 ●

lappato rettificato

86 ●

- 7667841 bianco lapp. rett.
- 7667881 beige lapp. rett.
- 7667851 grigio lapp. rett.
- 7667861 fumo lapp. rett.
- 7667871 nero lapp. rett.

fumo

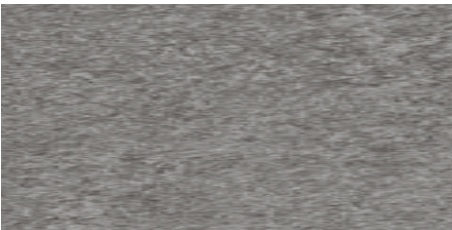

nero

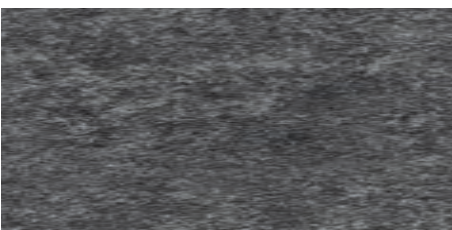

mosaico 5x5 (2"x2") 124 ●

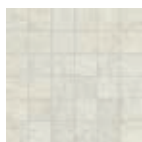

30x30 (12"x12")
7669031 bianco



30x30 (12"x12")
7669011 beige



30x30 (12"x12")
7669071 grigio

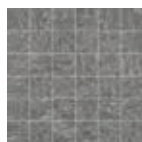

30x30 (12"x12")
7669051 fumo

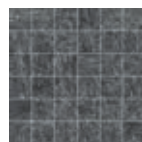

30x30 (12"x12")
7669091 nero

grid 1,5x10 (0,6"x3,75") 135 ●

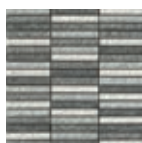

30x30 (12"x12")
7669222 mosaico mix

PEZZI SPECIALI trims - pieces speciales - formstücke - собьезлементы



battiscopa lappato rett.
7,5x29,7 (3"x12")
7669252 bianco lapp. rett.
7669272 grigio lapp. rett.
7669262 fumo lapp. rett.
7669282 nero lapp. rett.
7669242 beige lapp. rett.

12 ▲ 32 ☐

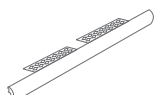

*** torello gradino nat. rett.**
4x59,5 (1,5"x24")
7671249 bianco rett.
7671259 grigio rett.
7671269 fumo rett.
7671279 nero rett.
7671289 beige rett.

99 ▲ 4 ☐

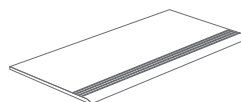

gradino step naturale
30x60 (12"x24")
7668191 bianco nat.
7668211 grigio nat.
7668201 fumo nat.
7668221 nero nat.
7668181 beige nat.

48 ▲ 7 ☐

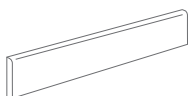

battiscopa naturale
7,5x60 (3"x24")
7668141 bianco nat.
7668161 grigio nat.
7668151 fumo nat.
7668171 nero nat.
7668131 beige nat.

24 ▲ 14 ☐

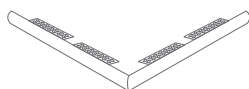

*** torello set angolare nat. rett.**
4x59,5 (1,5"x24")
7671299 bianco rett.
7671309 grigio rett.
7671319 fumo rett.
7671329 nero rett.
7671339 beige rett.

126 ▲ 2 set ☐

IMBALLI packing - emballages - verpackung - УПАКОВКА

F.TO NOMINALE / NOMINAL SIZE	mm.	PCS / BOX	M2 / BOX	BOX / PLT	M2 / PLT	KG. / PLT
30x60	9	7	1,26	40	50,40	989
29,7x59,5 rett.	9	7	1,24	40	49,60	973
30x30	8	13	1,17	48	56,16	960
29,7x29,7 rett.	9	11	0,97	48	46,56	912
15x30	8	23	1,04	75	78,00	1239
14,8x29,7 rett.	9	16	0,70	56	39,20	728
30x30 mosaico	9	11	1,00	30	30,00	570



luserna roc | stone effect

COLORI

colours - couleurs - farbe - ЦВѢТА

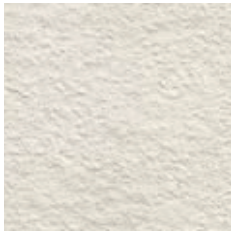

bianco

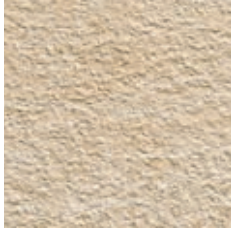

beige



mattone

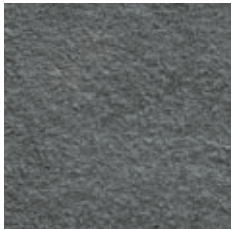

nero

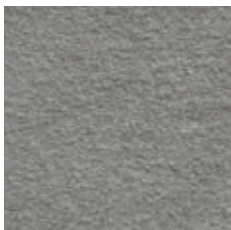

fumo



grigio

FORMATI

sizes - formats - format - ФОРМАТЫ



≠9

30x60 (12"x24") NATURALE

29,7x59,5 (12"x24") RETTIFICATO



30x30 (12"x12") NATURALE ≠8

29,7x29,7 (12"x12") RETTIFICATO ≠9



15x30 (6"x12") NATURALE ≠8

14,8x29,7 (6"x12") RETTIFICATO ≠9



15x15 (6"x6") NATURALE ≠8

14,8x14,8 (6"x6") RETTIFICATO ≠9



POSA 1/4



FUGA >3 mm



DIN 51130
R11



DIN 51097
A+B+C

bianco roc



30x60 (12"x24")
naturale 68 ●
 7666871 bianco roc
 7666861 beige roc
 7666831 grigio roc
 7666841 fumo roc
 7666851 nero roc
 7675921 mattone roc



30x30 (12"x12")
naturale 62 ●
 7637391 bianco roc
 7637381 beige roc
 7637351 grigio roc
 7637361 fumo roc
 7637371 nero roc
 7666651 mattone roc

beige roc



29,7x59,5 (12"x24")
rettificato 78 ●
 7667201 bianco roc rett.
 7667281 beige roc rett.
 7667211 grigio roc rett.
 7667221 fumo roc rett.
 7667271 nero roc rett.
 7675991 mattone roc rett.

29,7x29,7 (12"x12")
rettificato 78 ●
 7667291 bianco roc rett.
 7667331 beige roc rett.
 7667301 grigio roc rett.
 7667311 fumo roc rett.
 7667321 nero roc rett.

grigio roc

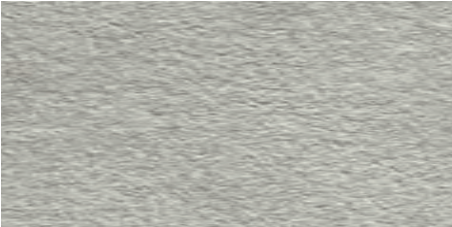

15x30 (6"x12")
naturale 62 ●
 7615041 bianco roc
 7615031 beige roc
 7615061 grigio roc
 7615051 fumo roc
 7615071 nero roc
 7615032 mattone roc



15x15 (6"x6")
naturale 62 ●
 7697311 bianco roc
 7697351 beige roc
 7697321 grigio roc
 7697331 fumo roc
 7697341 nero roc
 7697381 mattone roc

fumo roc

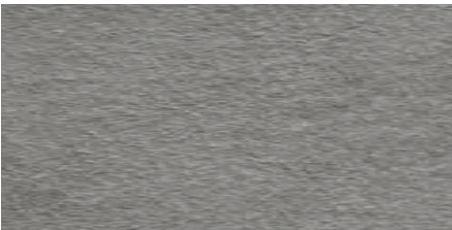

14,8x29,7 (6"x12")
rettificato 83 ●
 7667341 bianco roc rett.
 7667381 beige roc rett.
 7667351 grigio roc rett.
 7667361 fumo roc rett.
 7667371 nero roc rett.

14,8x14,8 (6"x6")
rettificato 87 ●
 7666581 bianco roc rett.
 7666621 beige roc rett.
 7666591 grigio roc rett.
 7666601 fumo roc rett.
 7666611 nero roc rett.
 7675992 mattone roc rett.

nero roc

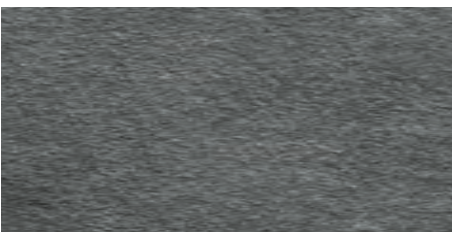

mattone roc



mosaico 5x5 (2"x2") 124 ●



30x30 (12"x12")
7669041 bianco roc

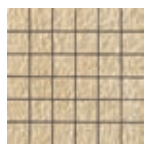

30x30 (12"x12")
7669021 beige roc



30x30 (12"x12")
7669081 grigio roc

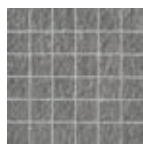

30x30 (12"x12")
7669061 fumo roc

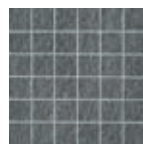

30x30 (12"x12")
7669101 nero roc

grid 1,5x10 (0,6"x3,75") 135 ●

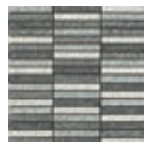

30x30 (12"x12")
7669221 mosaico mix roc

PEZZI SPECIALI trims - pieces speciales - formstücke - СОБИЕЭЛЕМЕНТЫ



battiscopa roc
7,5x30 (3"x12")
7669251 bianco roc
7669271 grigio roc
7669261 fumo roc
7669281 nero roc
7669241 beige roc
7669243 mattone roc
12 ▲ 32 ◻

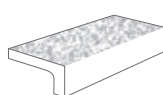

elemento elle pressa roc
15x30x3,5 (6"x12"x1,4")
7666489 bianco roc
7666509 grigio roc
7666499 fumo roc
7666519 nero roc
7666479 beige roc
7666518 mattone roc
44 ▲ 8 ◻

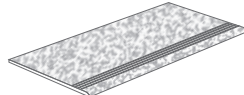

gradino step roc
30x60 (12"x24")
7668241 bianco roc
7668261 grigio roc
7668251 fumo roc
7668271 nero roc
7668231 beige roc
48 ▲ 7 ◻

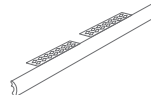

*** torello gradino rett.**
4x59,5 (1,5"x24")
7671249 bianco rett.
7671259 grigio rett.
7671269 fumo rett.
7671279 nero rett.
7671289 beige rett.
7671288 mattone rett.
99 ▲ 4 ◻

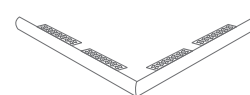

*** torello set angolare rett.**
4x59,5 (1,5"x24")
7671299 bianco rett.
7671309 grigio rett.
7671319 fumo rett.
7671329 nero rett.
7671339 beige rett.
7671338 mattone rett.
126 ▲ 2 set ◻

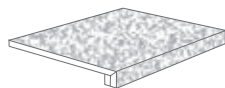

*** gradone DP rett.**
33,3x29,7 (13"x12")
7690004 bianco roc
7690034 grigio roc
7690024 fumo roc
7690044 nero roc
7690014 beige roc
7690054 mattone roc
78 ▲ 4 ◻

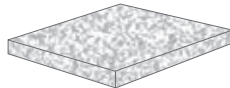

*** angolare DP SX rett.**
33,3x29,7 (13"x12")
7690124 bianco roc
7690154 grigio roc
7690144 fumo roc
7690164 nero roc
7690134 beige roc
7690174 mattone roc
102 ▲ 2 ◻

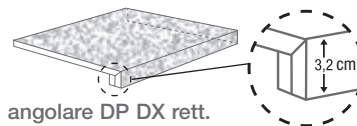

*** angolare DP DX rett.**
33,3x29,7 (13"x12")
7690064 bianco roc
7690094 grigio roc
7690084 fumo roc
7690104 nero roc
7690074 beige roc
7690114 mattone roc
102 ▲ 2 ◻

IMBALLI packing - emballages - verpackung - УПАКОВКА

F.TO NOMINALE / NOMINAL SIZE	mm.	PCS / BOX	M2 / BOX	BOX / PLT	M2 / PLT	KG. / PLT
30x60	9	7	1,26	40	50,40	989
29,7x59,5 rett.	9	7	1,24	40	49,60	973
30x30	8	13	1,17	48	56,16	960
29,7x29,7 rett.	9	11	0,97	48	46,56	912
15x30	8	23	1,04	75	78,00	1239
14,8x29,7 rett.	9	16	0,70	56	39,20	728
15x15	8	46	1,04	75	78,00	1239
14,8x14,8 rett.	9	32	0,70	56	39,20	800,80
30x30 mosaico	9	11	1,00	30	30,00	570



morestone | stone effect

COLORI

colours - couleurs - farbe - ЦВЕТА



white



sand



grey



dark

FORMATI

sizes - formats - format - ФОРМАТЫ

naturale

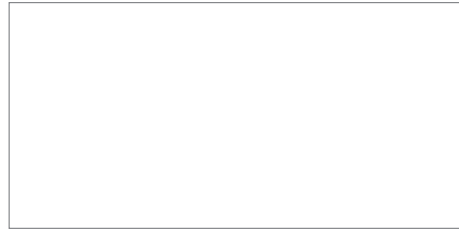

≠10

60x120 (24"x47") RETTIFICATO

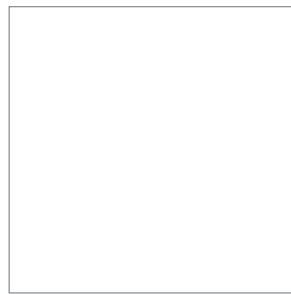

≠10

75,5x75,5 (30"x30") RETTIFICATO

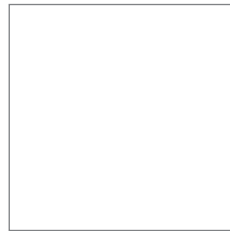

≠10

59,5x59,5 (24"x24") RETTIFICATO



30x60 (12"x24") NATURALE ≠9

29,7x59,5 (12"x24") RETTIFICATO ≠10

grip



≠10

59,5x59,5 (24"x24") RETTIFICATO

ONLY: sand - grey

SUPERFICI

SURFACE

SURFACE

OBERFLACHE

ПОВЕРХНОСТИ

Naturale

Natural

Naturelle

Matt

Натуральный

Grip

Grip

Grip

Grip

Grip

Grip



POSA 1/4



FUGA 2 mm
PER RETTIFICATO



FUGA >3 mm
PER NATURALE



DIN 51130
R11
(GRIP)



DIN 51097
A+B+C
(GRIP)

white



naturale



grip



60x120 (24"x47")

rettificato

7651005 dark rett.
7651065 grey rett.
7649985 sand rett.
7651025 white rett.

91 ●

59,5x59,5 (24"x24")

rettificato

7651095 grey grip rett.
7651105 sand grip rett.

81 ●

sand

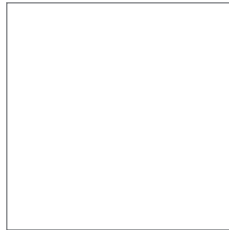

75,5x75,5 (30"x30")

rettificato

7690489 dark rett.
7690529 grey rett.
7690499 sand rett.
7690509 white rett.

87 ●



grey



59,5x59,5 (24"x24")

rettificato

7694045 dark rett.
7694035 grey rett.
7694005 sand rett.
7694015 white rett.

81 ●



30x60 (12"x24")

naturale #9

7693571 dark nat.
7693611 grey nat.
7693581 sand nat.
7693591 white nat.

68 ●

29,7x59,5 (12"x24")

rettificato #10

7693905 dark rett.
7693895 grey rett.
7693885 sand rett.
7693875 white rett.

81 ●

dark



mosaico 5x5 (2"x2") #9 124 ●



30x30 (12"x12")
7693911 white

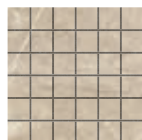

30x30 (12"x12")
7693921 sand

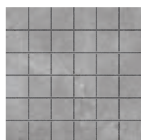

30x30 (12"x12")
7693931 grey

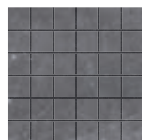

30x30 (12"x12")
7693941 dark

listellato #10 131 ●



30x60 (12"x24")
7693951 white



30x60 (12"x24")
7693961 sand



30x60 (12"x24")
7693971 grey



30x60 (12"x24")
7693981 dark

PEZZI SPECIALI trims - pieces speciales - formstücke - СОБЫЕЭЛЕМЕНТЫ

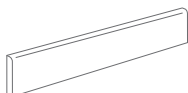

battiscopa naturale
7,5x60 (3"x24")
7693593 white nat.
7693583 sand nat.
7693613 grey nat.
7693573 dark nat.

24 ▲ 14 ◻

battiscopa rett.

7,5x59,5 (3"x24")
7693643 white rett.
7693633 sand rett.
7693663 grey rett.
7693623 dark rett.

24 ▲ 14 ◻

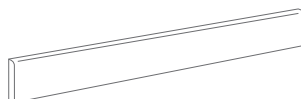

battiscopa rett.
7,5x120 (3"x47")
7651026 white rett.
7649986 sand rett.
7651066 grey rett.
7651006 dark rett.

48 ▲ 4 ◻

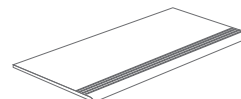

gradino step naturale #9
30x60 (12"x24")
7693594 white nat.
7693584 sand nat.
7693614 grey nat.
7693574 dark nat.

48 ▲ 7 ◻

gradino step rett. #10

29,7x59,5 (12"x24")
7693644 white rett.
7693634 sand rett.
7693664 grey rett.
7693624 dark rett.

48 ▲ 7 ◻

IMBALLI packing - emballages - verpackung - УПАКОВКА

F.TO NOMINALE / NOMINAL SIZE	mm.	PCS / BOX	M2 / BOX	BOX / PLT	M2 / PLT	KG. / PLT
60x120 rett.	10	2	1,44	36	51,84	1170
75,5x75,5 rett.	10	2	1,14	42	47,88	1138
59,5x59,5 rett.	10	3	1,062	40	42,48	916
30x60	9	7	1,26	40	50,40	989,2
29,7x59,5 rett.	10	7	1,24	36	44,64	1008
30x30 mosaico	9	11	1	-	-	-
30x60 listellato	10	4	0,72	-	-	-



phoenix | stone effect

COLORI

colours - couleurs - farbe - ЦВѢТА

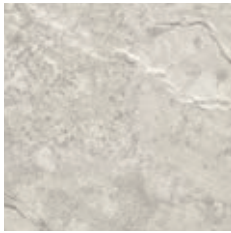

moon

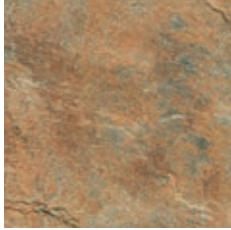

sun

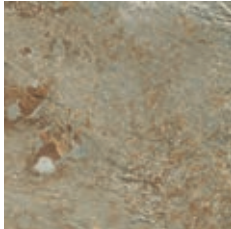

canyon



rainbow

FORMATI

sizes - formats - format - ФОРМАТЫ

naturale



15x90 (6"x36") NATURALE



30x60 (12"x24") NATURALE

29,7x59,5 (12"x24") RETTIFICATO



14,8x59,5 (6"x24") RETTIFICATO



14,8x14,8 (6"x6") RETTIFICATO

grip



30x60 (12"x24") NATURALE

ONLY: moon - sun - rainbow

SUPERFICI

SURFACE

SURFACE

OBERFLACHE

ПОВЕРХНОСТИ

Naturale

Natural

Naturelle

Matt

Натуральный

Grip

Grip

Grip

Grip

Grip

Grip



POSA 1/4



FUGA 2 mm
PER RETTIFICATO



FUGA >3 mm
PER NATURALE



DIN 51130
R11
(GRIP)



DIN 51097
A+B+C
(GRIP)

moon

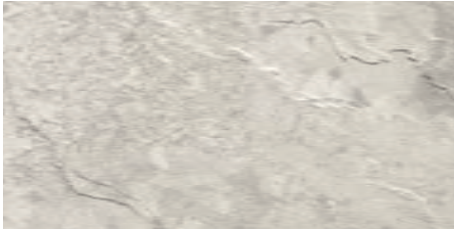

naturale



15x90 (6"x36")
naturale 76 ●
 7670049 moon nat.
 7670059 sun nat.
 7670069 canyon nat.
 7670079 rainbow nat.

grip



30x60 (12"x24")
grip 68 ●
 7693991 moon grip
 7694001 sun grip
 7694011 rainbow grip

sun



30x60 (12"x24")
naturale 68 ●
 7679681 moon nat.
 7679691 sun nat.
 7679701 canyon nat.
 7679721 rainbow nat.

canyon

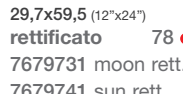
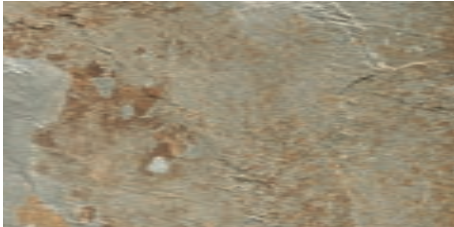

29,7x59,5 (12"x24")
rettificato 78 ●
 7679731 moon rett.
 7679741 sun rett.
 7679751 canyon rett.
 7679761 rainbow rett.



14,8x59,5 (6"x24")
rettificato 87 ●
 7679961 moon rett.
 7679971 sun rett.
 7679981 canyon rett.
 7679991 rainbow rett.

rainbow

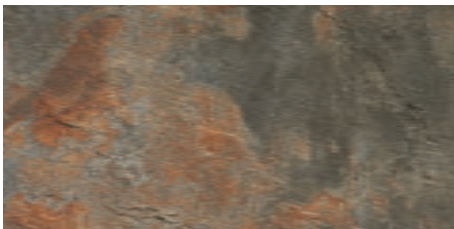

14,8x14,8 (6"x6")
rettificato 87 ●
 7681001 moon rett.
 7681011 sun rett.
 7681021 canyon rett.
 7681031 rainbow rett.

mosaico 5x5 (2"x2") 124 ●

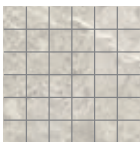

30x30 (12"x12")
 7679771 moon

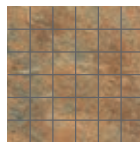

30x30 (12"x12")
 7679781 sun

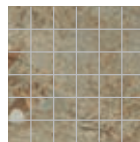

30x30 (12"x12")
 7679791 canyon



30x30 (12"x12")
 7679801 rainbow

brick 5x15 (2"x6") 124 ●



30x30 (12"x12")
 7679811 moon



30x30 (12"x12")
 7679821 sun



30x30 (12"x12")
 7679831 canyon



30x30 (12"x12")
 7679841 rainbow



phoenix | stone effect

sun 30x60 (12"x24") sun 15x90 (6"x36")

PEZZI SPECIALI trims - pieces speciales - formstücke - СОБИЕЭЛЕМЕНТЫ



battiscopa

7,5x30 (3"x12")

7679682 moon







7679692 sun

7679702 canyon

7679722 rainbow

12 ▲ 32 📦

IMBALLI packing - emballages - verpackung - УПАКОВКА

F.TO NOMINALE / NOMINAL SIZE	 mm.	 PCS / BOX	 M2 / BOX	 BOX / PLT	 M2 / PLT	 KG. / PLT
15x90	9	7	0,945	48	45,36	884,544
30x60	9	7	1,26	40	50,40	989
29,7x59,5 rett.	9	7	1,24	40	49,60	973
14,8x59,5 rett.	9	14	1,23	40	49,20	965
14,8x14,8 rett.	9	32	0,70	56	39,20	800,80
30x30 mosaico - brick	9	11	1	-	-	-



volcano | stone effect

COLORI

colours - couleurs - farbe - ЦВЕТА



bianco



cenere



grigio

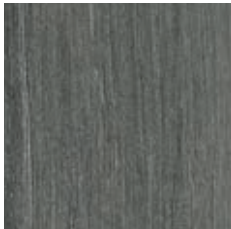

nero

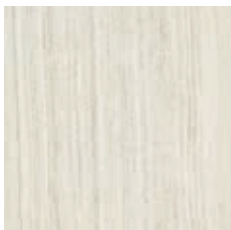

sabbia

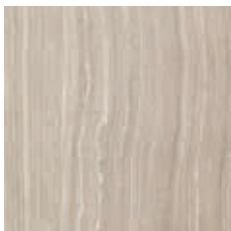

tortora



marrone

FORMATI

sizes - formats - format - ФОРМАТЫ



45x90 (18"x36") RETTIFICATO



22,5x90 (9"x36") RETTIFICATO



15x90 (6"x36") RETTIFICATO



11x90 (4,3"x36") RETTIFICATO



30x60 (12"x24") NATURALE

29,7x59,5 (12"x24") RETTIFICATO



15x60 (6"x24") NATURALE

14,8x59,5 (6"x24") RETTIFICATO

SUPERFICI

SURFACE

SURFACE

OBERFLACHE

ПОВЕРХНОСТИ

Naturale

Natural

Naturelle

Matt

Натуральный

Lappato

Semi-Polished

Lappato

Halbpoliert

Полуполированный



POSA 1/4



FUGA 2 mm
PER RETTIFICATO



FUGA >3 mm
PER NATURALE

bianco



sabbia



cenere



tortora



grigio



marrone



nero

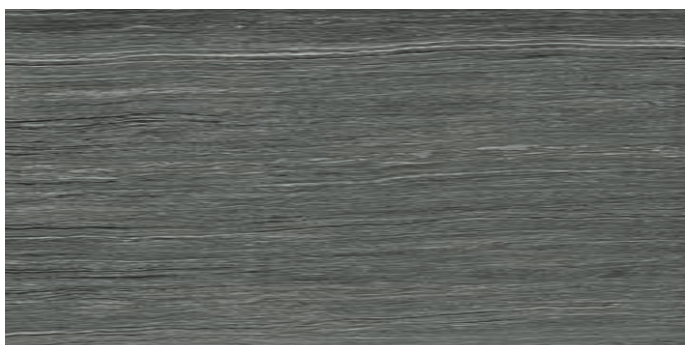



45x90 (18"x36")
rettificato 85 ●
7661565 bianco nat. rett.
7659975 cenere nat. rett.
7659985 grigio nat. rett.
7661585 nero nat. rett.
7661605 sabbia nat. rett.
7659965 tortora nat. rett.
7659955 marrone nat. rett.

lappato rettificato 93 ●
7661575 bianco lapp. rett.
7660015 cenere lapp. rett.
7660025 grigio lapp. rett.
7661595 nero lapp. rett.
7661615 sabbia lapp. rett.
7660005 tortora nat. rett.
7659995 marrone lapp. rett.



15x90 (6"x36")
rettificato 85 ●
7661445 bianco nat. rett.
7660175 cenere nat. rett.
7660185 grigio nat. rett.
7661435 nero nat. rett.
7661495 sabbia nat. rett.
7660165 tortora nat. rett.
7660155 marrone nat. rett.

lappato rettificato 93 ●
7660365 bianco lapp. rett.
7660295 cenere lapp. rett.
7660305 grigio lapp. rett.
7660355 nero lapp. rett.
7660345 sabbia lapp. rett.
7660285 tortora lapp. rett.
7660275 marrone lapp. rett.



22,5x90 (9"x36")
rettificato 85 ●
7661515 bianco nat. rett.
7660065 cenere nat. rett.
7660095 grigio nat. rett.
7661505 nero nat. rett.
7661525 sabbia nat. rett.
7660045 tortora nat. rett.
7660035 marrone nat. rett.

lappato rettificato 93 ●
7661545 bianco lapp. rett.
7660135 cenere lapp. rett.
7660145 grigio lapp. rett.
7661535 nero lapp. rett.
7661555 sabbia lapp. rett.
7660125 tortora lapp. rett.
7660115 marrone lapp. rett.



11x90 (4,3"x36")
rettificato 85 ●
7660385 bianco nat. rett.
7660215 cenere nat. rett.
7660225 grigio nat. rett.
7660375 nero nat. rett.
7661395 sabbia nat. rett.
7660205 tortora nat. rett.
7660195 marrone nat. rett.

lappato rettificato 93 ●
7661415 bianco lapp. rett.
7660255 cenere lapp. rett.
7660265 grigio lapp. rett.
7661405 nero lapp. rett.
7661425 sabbia lapp. rett.
7660245 tortora lapp. rett.
7660235 marrone lapp. rett.



30x60 (12"x24")
naturale 68 ●
7672225 bianco nat.
7672095 cenere nat.
7672105 grigio nat.
7672215 nero nat.
7672235 sabbia nat.
7672085 tortora nat.
7672075 marrone nat.

29,7x59,5 (12"x24")
rettificato 78 ●
7672405 bianco nat. rett.
7672135 cenere nat. rett.
7672145 grigio nat. rett.
7672475 nero nat. rett.
7672445 sabbia nat. rett.
7672125 tortora nat. rett.
7672115 marrone nat. rett.

lappato rettificato 86 ●
7672465 bianco lapp. rett.
7672175 cenere lapp. rett.
7672185 grigio lapp. rett.
7672485 nero lapp. rett.
7672495 sabbia lapp. rett.
7672165 tortora lapp. rett.
7672155 marrone lapp. rett.



15x60 (6"x24")
naturale 68 ●
7700251 bianco nat.
7700241 cenere nat.
7700231 grigio nat.
7700261 nero nat.
7700291 sabbia nat.
7700281 tortora nat.
7700271 marrone nat.

14,8x59,5 (6"x24")
rettificato 87 ●
7674445 bianco nat. rett.
7674455 cenere nat. rett.
7674465 grigio nat. rett.
7674485 nero nat. rett.
7674495 sabbia nat. rett.
7674505 tortora nat. rett.
7674475 marrone nat. rett.

lappato rettificato 95 ●
7674515 bianco lapp. rett.
7674525 cenere lapp. rett.
7674535 grigio lapp. rett.
7674555 nero lapp. rett.
7674565 sabbia lapp. rett.
7674575 tortora lapp. rett.
7674545 marrone lapp. rett.

mosaico 5x5 (2"x2") 124 ●

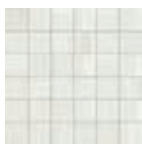

30x30 (12"x12")
7673855 bianco nat.
7673925 bianco lapp.

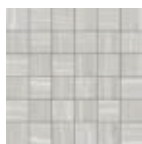

30x30 (12"x12")
7673865 cenere nat.
7673935 cenere lapp.



30x30 (12"x12")
7673875 grigio nat.
7673945 grigio lapp.



30x30 (12"x12")
7673895 nero nat.
7673965 nero lapp.

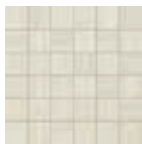

30x30 (12"x12")
7673905 sabbia nat.
7673975 sabbia lapp.

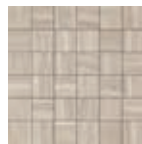

30x30 (12"x12")
7673915 tortora nat.
7673985 tortora lapp.



30x30 (12"x12")
7673885 marrone nat.
7673955 marrone lapp.

listellato 131 ●



30x60 (12"x24")
7673995 bianco nat.
7674065 bianco lapp.



30x60 (12"x24")
7674005 cenere nat.
7674075 cenere lapp.



30x60 (12"x24")
7674015 grigio nat.
7674085 grigio lapp.



30x60 (12"x24")
7674035 nero nat.
7674105 nero lapp.



30x60 (12"x24")
7674045 sabbia nat.
7674115 sabbia lapp.



30x60 (12"x24")
7674055 tortora nat.
7674125 tortora lapp.



30x60 (12"x24")
7674025 marrone nat.
7674095 marrone lapp.

listello drops 42 ▲ 6 ◻



2x59,5 (0,8"x24")
7674135 bianco lapp. rett.



2x59,5 (0,8"x24")
7674145 cenere lapp. rett.



2x59,5 (0,8"x24")
7674175 nero lapp. rett.



battiscopa naturale
7,5x30 (3"x12")
 7677055 bianco nat.
 7677045 cenere nat.
 7677025 grigio nat.
 7677085 marrone nat.
 7677035 nero nat.
 7677065 sabbia nat.
 7677075 tortora nat.

12 ▲ 32 📦

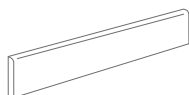

battiscopa naturale
7,5x60 (3"x24")
 7673365 bianco nat.
 7673375 cenere nat.
 7673385 grigio nat.
 7673395 marrone nat.
 7673405 nero nat.
 7673415 sabbia nat.
 7673425 tortora nat.

24 ▲ 14 📦

battiscopa naturale rett.
7,5x59,5 (3"x24")
 7673435 bianco nat. rett.
 7673445 cenere nat. rett.
 7673455 grigio nat. rett.
 7673465 marrone nat. rett.
 7673475 nero nat. rett.
 7673485 sabbia nat. rett.
 7673495 tortora nat. rett.

24 ▲ 14 📦

battiscopa lappato rett.
7,5x59,5 (3"x24")
 7677405 bianco lapp. rett.
 7677415 cenere lapp. rett.
 7677425 grigio lapp. rett.
 7677435 marrone lapp. rett.
 7677445 nero lapp. rett.
 7677455 sabbia lapp. rett.
 7677465 tortora lapp. rett.

24 ▲ 14 📦

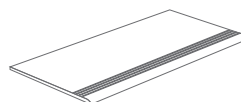

gradino step naturale
30x60 (12"x24")
 7673505 bianco nat.
 7673515 cenere nat.
 7673525 grigio nat.
 7673535 marrone nat.
 7673545 nero nat.
 7673555 sabbia nat.
 7673565 tortora nat.

48 ▲ 7 📦

gradino step naturale rett.
29,7x59,5 (12"x24")
 7673575 bianco nat. rett.
 7673585 cenere nat. rett.
 7673595 grigio nat. rett.
 7673605 marrone nat. rett.
 7673615 nero nat. rett.
 7673625 sabbia nat. rett.
 7673635 tortora nat. rett.

48 ▲ 7 📦

gradino step lappato rett.
29,7x59,5 (12"x24")
 7673645 bianco lapp. rett.
 7673655 cenere lapp. rett.
 7673665 grigio lapp. rett.
 7673675 marrone lapp. rett.
 7673685 nero lapp. rett.
 7673695 sabbia lapp. rett.
 7673705 tortora lapp. rett.

53 ▲ 7 📦

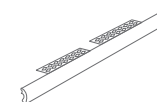

*** torelo gradino nat. rett.**
4x59,5 (1,5"x24")
 7673719 bianco rett.
 7673729 cenere rett.
 7673739 grigio rett.
 7673749 marrone rett.
 7673759 nero rett.
 7673769 sabbia rett.
 7673779 tortora rett.

99 ▲ 4 📦

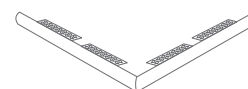

*** torelo set angolare nat. rett.**
4x59,5 (1,5"x24")
 7673789 bianco rett.
 7673799 cenere rett.
 7673809 grigio rett.
 7673819 marrone rett.
 7673829 nero rett.
 7673839 sabbia rett.
 7673849 tortora rett.

126 ▲ 2 set 📦

IMBALLI packing - emballages - verpackung - УПАКОВКА

F.TO NOMINALE / NOMINAL SIZE	mm.	PCS / BOX	M2 / BOX	BOX / PLT	M2 / PLT	KG. / PLT
45x90 rett.	10	3	1,215	30	36,45	840
22,5x90 rett.	10	6	1,215	36	43,74	972
15x90 rett.	10	8	1,08	48	51,84	1200
11x90 rett.	10	12	1,19	36	42,84	1018
30x60	9	7	1,26	40	50,40	989
29,7x59,5 rett.	9	7	1,24	40	49,60	973
15x60	9	14	1,26	40	50,40	989
14,8x59,5 rett.	9	14	1,23	40	49,20	973
30x60 listellato	9	4	0,72	-	-	-
30x30 mosaico	9	11	1	-	-	-

concrete and terracotta effect

effetto cemento e cotto
imitation ciments et cotto
Cotto und Beton-Optik
Цемент и Котто

block
pag. 88



borgate fiorentine
pag. 92

brera
pag. 94

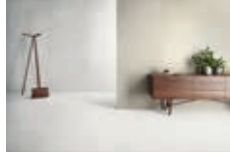

concreta
pag. 100

cottoantico
pag. 104

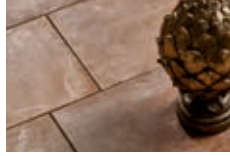

cottocemento
pag. 108

ferrocemento
pag. 116



global
pag. 128

laredo
pag. 138



logica
pag. 140

metropolitan
pag. 144



neutra
pag. 148

salento
pag. 156



urbandeck
pag. 160

valencia
pag. 166





COLORI

colours - couleurs - farbe - ЦВЕТА



beige



tortora

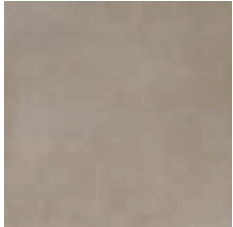

greige

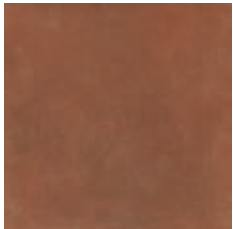

rosso

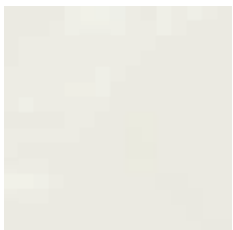

bianco

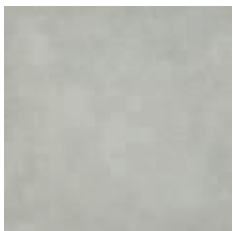

cenere

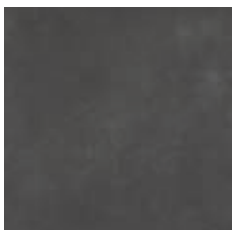

carbone

FORMATI

sizes - formats - format - ФОРМАТЫ



59,5x59,5 (24"x24") RETTIFICATO $\neq 10$



29,7x59,5 (12"x24") RETTIFICATO $\neq 10$



29,7x29,7 (12"x12") RETTIFICATO $\neq 10$

SUPERFICI

SURFACE
SURFACE
OBERFLACHE
ПОВЕРХНОСТИ

Naturale

Natural
Naturelle
Matt

Натуральный

Lappato

Semi-Polished

Lappato

Halbpoliert

Полуполированный



POSA 1/4



FUGA 2 mm
PER RETTIFICATO



FUGA >3 mm
PER NATURALE

bianco



beige

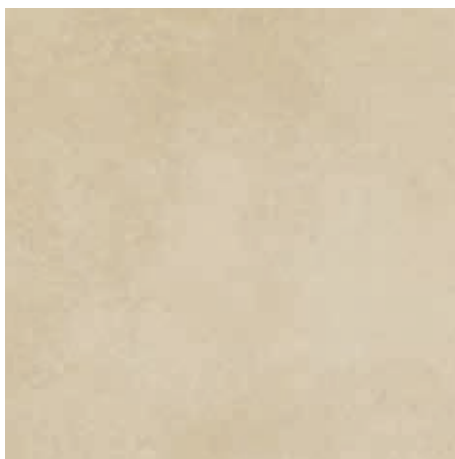

rosso



cenere

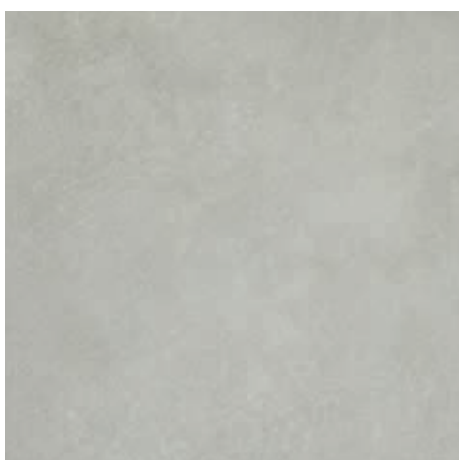

tortora



carbone

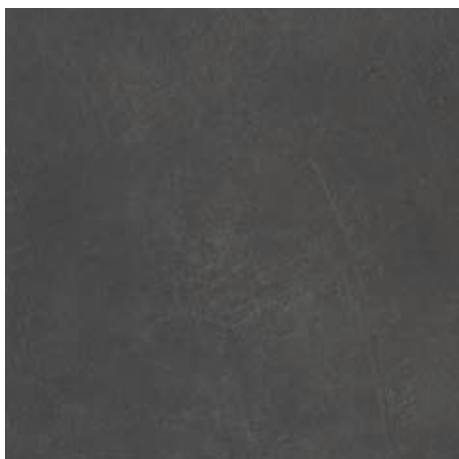

greige

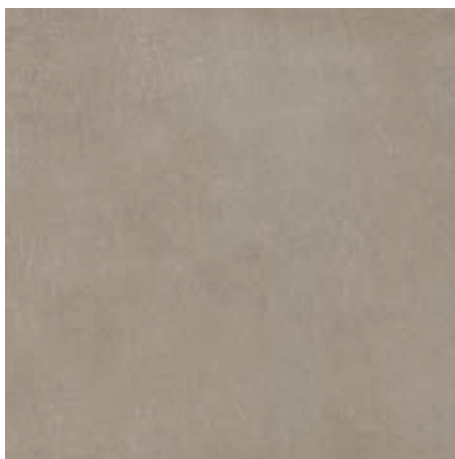

block | concrete and terracotta effect

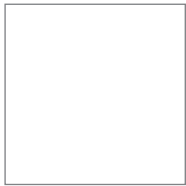

59,5x59,5 (24"x24")
naturale rett. 81 ●
 7686155 bianco nat. rett.
 7686595 cenere nat. rett.
 7686625 carbone nat. rett.
 7686575 beige nat. rett.
 7686605 tortora nat. rett.
 7687305 greige nat. rett.
 7686585 rosso nat. rett.

lappato rett. 88 ●
 7686165 bianco lapp. rett.
 7686655 cenere lapp. rett.
 7686685 carbone lapp. rett.
 7686635 beige lapp. rett.
 7686665 tortora lapp. rett.
 7687315 greige lapp. rett.
 7686645 rosso lapp. rett.



29,7x59,5 (12"x24")
naturale rett. 81 ●
 7686695 bianco nat. rett.
 7686725 cenere nat. rett.
 7686755 carbone nat. rett.
 7686705 beige nat. rett.
 7686735 tortora nat. rett.
 7687325 greige nat. rett.
 7686715 rosso nat. rett.

lappato rett. 88 ●
 7686765 bianco lapp. rett.
 7686795 cenere lapp. rett.
 7686885 carbone lapp. rett.
 7686775 beige lapp. rett.
 7686805 tortora lapp. rett.
 7687335 greige lapp. rett.
 7686785 rosso lapp. rett.



29,7x29,7 (12"x12")
naturale rett. 81 ●
 7686825 bianco nat. rett.
 7686855 cenere nat. rett.
 7686895 carbone nat. rett.
 7686835 beige nat. rett.
 7686865 tortora nat. rett.
 7687355 greige nat. rett.
 7686845 rosso nat. rett.

29,7x29,7 (12"x12")
lappato rett. 88 ●
 7686905 bianco lapp. rett.
 7686935 cenere lapp. rett.
 7686965 carbone lapp. rett.
 7686915 beige lapp. rett.
 7686945 tortora lapp. rett.
 7687345 greige lapp. rett.
 7686925 rosso lapp. rett.

mosaico 5x5 (2"x2") 124 ●

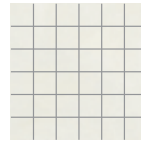

30x30 (12"x12")
 7686975 bianco nat.
 7687045 bianco lapp.

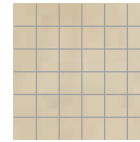

30x30 (12"x12")
 7686985 beige nat.
 7687055 beige lapp.

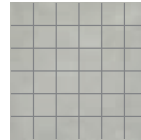

30x30 (12"x12")
 7687005 cenere nat.
 7687075 cenere lapp.

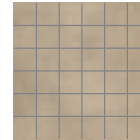

30x30 (12"x12")
 7687015 tortora nat.
 7687085 tortora lapp.



30x30 (12"x12")
 7687035 carbone nat.
 7687105 carbone lapp.



30x30 (12"x12")
 7687365 greige nat.
 7687295 greige lapp.

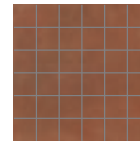

30x30 (12"x12")
 7686995 rosso nat.
 7687065 rosso lapp.

PEZZI SPECIALI trims - pieces speciales - formstücke - СОБЫЕЭЛЕМЕНТЫ



battiscopa naturale rett.
7,5x59,5 (3"x24")
 7678265 beige nat. rett.
 7678305 bianco nat. rett.
 7678325 carbone nat. rett.
 7678315 cenere nat. rett.
 7678285 greige nat. rett.
 7678295 rosso nat. rett.
 7678275 tortora nat. rett.

24 ▲ 14 ◻



battiscopa lappato rett.
7,5x59,5 (3"x24")
 7678405 beige lapp. rett.
 7678445 bianco lapp. rett.
 7678465 carbone lapp. rett.
 7678455 cenere lapp. rett.
 7678425 greige lapp. rett.
 7678435 rosso lapp. rett.
 7678415 tortora lapp. rett.

24 ▲ 14 ◻

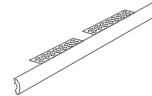

* **torello gradino nat. rett.**
4x59,5 (1,5"x24")
 7666948 beige nat. rett.
 7666934 bianco nat. rett.
 7666943 carbone nat. rett.
 7666935 cenere nat. rett.
 7666945 greige nat. rett.
 7666938 rosso nat. rett.
 7666952 tortora nat. rett.

99 ▲ 4 ◻

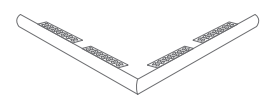

* **torello set angolare nat. rett.**
4x59,5 (1,5"x24")
 7666947 beige nat. rett.
 7666937 bianco nat. rett.
 7666942 carbone nat. rett.
 7666940 cenere nat. rett.
 7666944 greige nat. rett.
 7666350 rosso nat. rett.
 7666950 tortora nat. rett.

126 ▲ 2 set ◻

IMBALLI packing - emballages - verpackung - УПАКОВКА

F.TO NOMINALE / NOMINAL SIZE	mm.	PCS / BOX	M2 / BOX	BOX / PLT	M2 / PLT	KG. / PLT
59,5x59,5 rett.	10	3	1,062	40	42,48	960
29,7x59,5 rett.	10	7	1,24	36	44,64	1008
29,7x29,7 rett.	10	11	0,97	48	46,56	1056
30x30 mosaico	10	11	1	-	-	-



borgate fiorentine | concrete a terracotta effect

borgate fiorentine

baruffi



monterinaldi



33,3x33,3 (13"x13") 60 ●
6440232 baruffi
6440242 monterinaldi
6440212 falciani
6440222 borgaccio



16,5x33,3 (6"x13") 81 ●
6432021 baruffi
6432031 monterinaldi
6432001 falciani
6432011 borgaccio

falciani



borgaccio



16,5x16,5 (6"x6") 81 ●
6431301 baruffi
6431311 monterinaldi
6431281 falciani
6431291 borgaccio

tappeto 96 ▲ 4



33,3x33,3 (13"x13")
6440661 baruffi

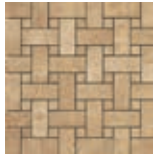

33,3x33,3 (13"x13")
6440671 monterinaldi



33,3x33,3 (13"x13")
6440641 falciani

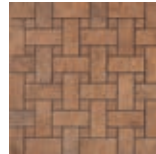

33,3x33,3 (13"x13")
6440651 borgaccio

GS

V3



FUGA >3 mm

borgate fiorentine | concrete and terracotta effect

PEZZI SPECIALI trims - pieces speciales - formstücke - СОБЫЕЭЛЕМЕНТЫ

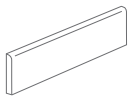

battiscopa
8x33,3 (3,2"x13")
6440689 falciani
6440691 borgaccio
6440709 baruffi
6440719 monterinaldi

12 ▲ 32

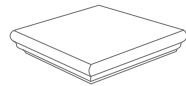

* **angolare con torello**
33,3x33,3 (13"x13")
6440761 falciani
6440771 borgaccio
6440781 baruffi
6440791 monterinaldi

93 ▲ 2

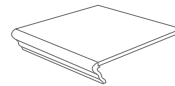

* **gradone con torello**
33,3x33,3 (13"x13")
6440721 falciani
6440731 borgaccio
6440741 baruffi
6440751 monterinaldi

66 ▲ 6

MODULARITÀ PREVISTA CON FUGA DI 3 MM. NELL'AMBITO DELLO STESSO CALIBRO.

MODULAR LAYING WITH A 3 MM. JOINT WITHIN THE SAME SIZE.

POSE MODULAIRE (OPUS) PREVUE POUR UN JOINT DE 3 MM, MÊME CALIBRE POUR TOUS LES FORMATS POSÉS.

MODULIERTE VERLEGUNG MIT 3 MM. FUGE IN RAHMEN DER GLEICHEN FORMATABMESSUNGEN.

ПРЕДУСМОТРЕННАЯ МОДУЛЬНОСТЬ С ШВОМ 3 MM В РАМКАХ ОДНОГО И ТОГО ЖЕ КАЛИБРА.

IMBALLI packing - emballages - verpackung - УПАКОВКА

F.TO NOMINALE / NOMINAL SIZE	mm.	PCS / BOX	M2 / BOX	BOX / PLT	M2 / PLT	KG. / PLT
33,3x33,3	8	14	1,55	44	68,2	1100
16,5x33,3	8	16	0,88	68	59,84	1020
16,5x16,5	8	32	0,87	68	59,16	1156



COLORI

colours - couleurs - farbe - ЦВЕТА



bianco



beige



perla



grigio

FORMATI

sizes - formats - format - ФОРМАТЫ

naturale

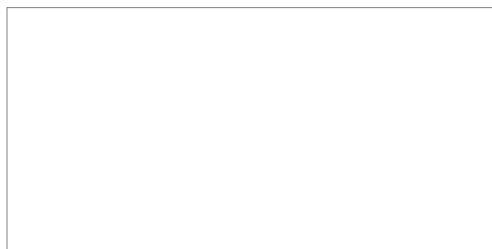

90,2x180,7 (36"x72") RETTIFICATO ≠10



90,2x90,2 (36"x36") RETTIFICATO ≠10



45x90,2 (18"x36") RETTIFICATO ≠10



59,5x59,5 (24"x24") RETTIFICATO ≠10



29,7x59,5 (12"x24") RETTIFICATO ≠10

grip



59,5x59,5 (24"x24") RETTIFICATO ≠10



29,7x59,5 (12"x24") RETTIFICATO ≠10

SUPERFICI

SURFACE
SURFACE
OBERFLACHE
ПОВЕРХНОСТИ

Naturale

Natural
Naturelle
Matt
Натуральный

Grip

Grip
Grip
Grip
Grip
Grip



FUGA 2 mm



DIN 51130
R11 (GRIP)



DIN 51097
A+B+C (GRIP)

bianco



naturale

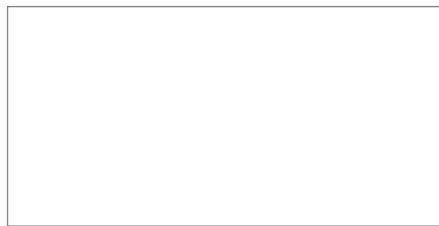

90,2x180,7 (36"x72")
7680199 rett.

106 ●

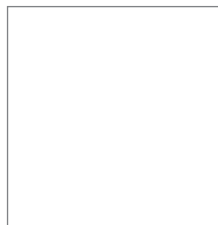

90,2x90,2 (36"x36")
7680059 rett.

99 ●



45x90,2 (18"x36")
7680239 rett.

99 ●



59,5x59,5 (24"x24")
7691125 rett.

81 ●



29,7x59,5 (12"x24")
7691685 rett.

81 ●

grip



59,5x59,5 (24"x24")
7691815 grip rett.

81 ●



29,7x59,5 (12"x24")
7691817 grip rett.

81 ●

beige



naturale

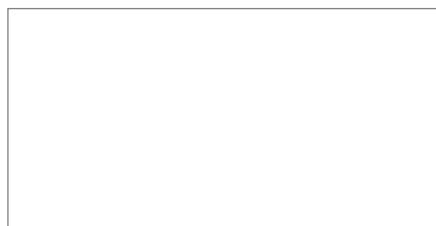

90,2x180,7 (36"x72")

7680189 rett.

106 ●

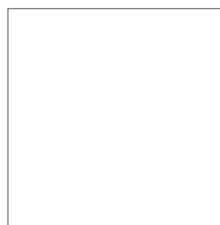

90,2x90,2 (36"x36")

7680049 rett.

99 ●



45x90,2 (18"x36")

7680229 rett.

99 ●



59,5x59,5 (24"x24")

7691115 rett.

81 ●



29,7x59,5 (12"x24")

7691695 rett.

81 ●

grip



59,5x59,5 (24"x24")

7691795 grip rett.

81 ●



29,7x59,5 (12"x24")

7691796 grip rett.

81 ●

perla



naturale

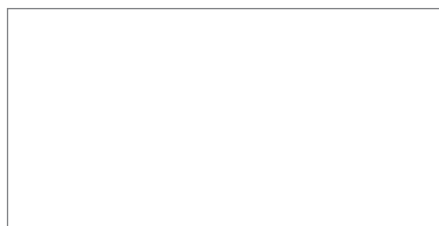

90,2x180,7 (36"x72")

7680209 rett.

106 ●

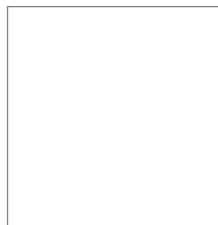

90,2x90,2 (36"x36")

7680069 rett.

99 ●



45x90,2 (18"x36")

7680249 rett.

99 ●



59,5x59,5 (24"x24")

7691145 rett.

81 ●



29,7x59,5 (12"x24")

7691715 rett.

81 ●

grip



59,5x59,5 (24"x24")

7691855 grip rett.

81 ●



29,7x59,5 (12"x24")

7691856 grip rett.

81 ●

PEZZI SPECIALI trims - pieces speciales - formstücke - СОБЫЕЭЛЕМЕНТЫ

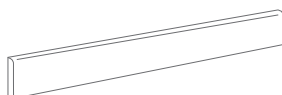

battiscopa rettificato 40 ▲

7,5x90,2 (3"x36")

5 ▢

7680050 beige rett.

7680060 bianco rett.

7680080 grigio rett.

7680070 perla rett.



battiscopa rettificato 24 ▲

7,5x59,5 (3"x24")

14 ▢

7691696 beige rett.

7691686 bianco rett.

7691706 grigio rett.

7691716 perla rett.

grigio



naturale



90,2x180,7 (36"x72")
7680219 rett.

106 ●

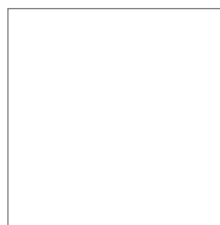

90,2x90,2 (36"x36")
7680079 rett.

99 ●



45x90,2 (18"x36")
7680259 rett.

99 ●



59,5x59,5 (24"x24")
7691135 rett.

81 ●



29,7x59,5 (12"x24")
7691705 rett.

81 ●

grip



59,5x59,5 (24"x24")
7691835 grip rett.

81 ●



29,7x59,5 (12"x24")
7691836 grip rett.

81 ●

brera | concrete and terracotta effect

IMBALLI packing - emballages - verpackung - УПАКОВКА

F.TO NOMINALE / NOMINAL SIZE	mm.	PCS / BOX	M2 / BOX	BOX / PLT	M2 / PLT	KG. / PLT
90,2x180,7 rett.	10	1	1,63	30	48,90	1215
90,2x90,2 rett.	10	2	1,63	24	39,12	972
45x90,2 rett.	10	3	1,218	30	36,54	840
59,5x59,5 rett.	10	3	1,062	40	42,48	938
29,7x59,5 rett.	10	7	1,24	40	49,60	973



concreta | concrete and terracotta effect

COLORI

colours - couleurs - farbe - ЦВЕТА



sabbia

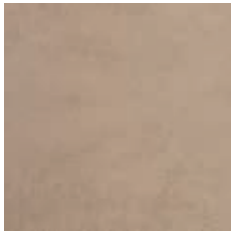

terra



polvere

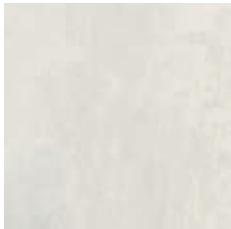

calce

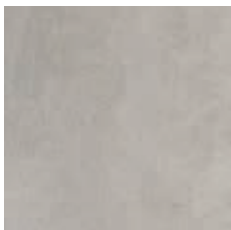

argilla

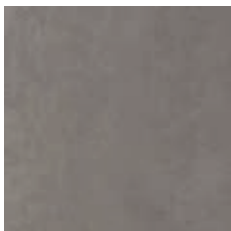

lava

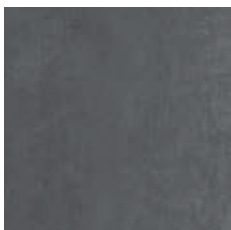

carbone

FORMATI

sizes - formats - format - ФОРМАТЫ

naturale



≠10

60x60 (24"x24") NATURALE

59,5x59,5 (24"x24") RETTIFICATO



≠9

30x60 (12"x24") NATURALE

29,7x59,5 (12"x24") RETTIFICATO



≠9

14,8x59,5 (6"x24") RETTIFICATO

A RICHIESTA / ON REQUEST / SUR DEMANDE / AUF ANFRAGE / A PETICIÓN



≠9

45x45 (18"x18")



≠9

29,7x29,7 (12"x12") RETTIFICATO

grip (corindonato)



≠9

45x45 (18"x18")

SUPERFICI

SURFACE

SURFACE

OBERFLACHE

ПОВЕРХНОСТИ

Naturale

Natural

Naturelle

Matt

Натуральный

Grip (Corindonato)

Grip

Grip

Grip

Grip



POSA 1/4



FUGA 2 mm
PER RETTIFICATO



FUGA >3 mm
PER NATURALE



DIN 51130
R11 (GRIP)



DIN 51097
A+B (GRIP)

sabbia



calce



naturale



60x60 (24"x24") 70 ●
 7685455 sabbia nat.
 7685445 terra nat.
 7685475 polvere nat.
 7685435 calce nat.
 7685485 argilla nat.
 7685465 lava nat.

59,5x59,5 (24"x24") 76 ●
 7685535 sabbia rett.
 7685525 terra rett.
 7685505 polvere rett.
 7685515 calce rett.
 7685555 argilla rett.
 7685545 lava rett.

terra



argilla



30x60 (12"x24") 65 ●
 7675745 sabbia nat.
 7675735 terra nat.
 7675765 polvere nat.
 7675725 calce nat.
 7675775 argilla nat.
 7675755 lava nat.
 7679125 carbone nat.

29,7x59,5 (12"x24") 75 ●
 7675805 sabbia rett.
 7675795 terra rett.
 7675825 polvere rett.
 7675785 calce rett.
 7675835 argilla rett.
 7675815 lava rett.
 7675786 carbone rett.

polvere



lava



45x45 (18"x18") 60 ●
 7652795 sabbia nat.
 7652825 terra nat.
 7652785 polvere nat.
 7652805 calce nat.
 7652815 argilla nat.
 7652835 lava nat.

carbone

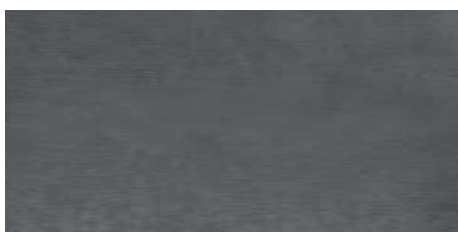

29,7x29,7 (12"x12") 75 ●
 7675865 sabbia rett.
 7675855 terra rett.
 7675885 polvere rett.
 7675845 calce rett.
 7675895 argilla rett.
 7675875 lava rett.

mosaico 5x5 (2"x2") 124 ●



45x45 (18"x18")
corindonato 60 ●
 7664915 sabbia cor.
 7665075 terra cor.
 7664905 polvere cor.
 7664705 calce cor.
 7664695 argilla cor.
 7664715 lava cor.

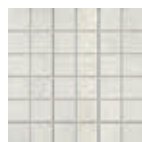

30x30 (12"x12")
 7676975 calce

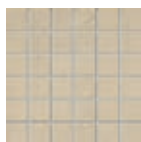

30x30 (12"x12")
 7677005 sabbia



30x30 (12"x12")
 7677015 terra

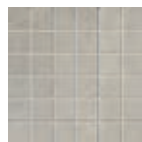

30x30 (12"x12")
 7676965 argilla

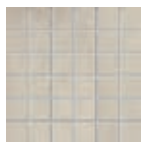

30x30 (12"x12")
 7676995 polvere



30x30 (12"x12")
 7676985 lava

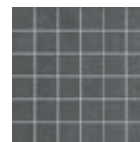

30x30 (12"x12")
 7676976 carbone

PEZZI SPECIALI trims - pieces speciales - formstücke - СОБИЕЭЛЕМЕНТЫ

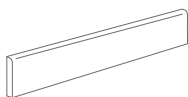

battiscopa
 7,5x60 (3"x24")
 7676005 argilla
 7676015 calce
 7676025 lava
 7676035 polvere
 7676045 sabbia
 7676055 terra
 7679127 carbone

24 ▲ 14 ◻

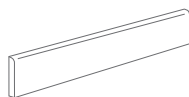

battiscopa rett.
 7,5x59,5 (3"x24")
 7685556 argilla rett.
 7685566 calce rett.
 7685536 lava rett.
 7685576 polvere rett.
 7685586 sabbia rett.
 7685596 terra rett.
 7685546 carbone rett.

24 ▲ 14 ◻



battiscopa
 8x45 (3,1"x18")
 7652876 argilla
 7652866 calce
 7652896 lava
 7652846 polvere
 7652856 sabbia
 7652886 terra

21 ▲ 12 ◻

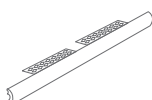

* **torello gradino rett.**
 4x59,5 (1,5"x24")
 7676069 argilla
 7676079 calce
 7676089 lava
 7676099 polvere
 7676109 sabbia
 7676119 terra

99 ▲ 4 ◻

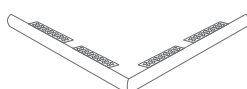

* **torello set angolare rett.**
 4x59,5 (1,5"x24")
 7676129 argilla
 7676139 calce
 7676149 lava
 7676150 polvere
 7676169 sabbia
 7676179 terra

126 ▲ 2 set ◻

IMBALLI packing - emballages - verpackung - УПАКОВКА

F.TO NOMINALE / NOMINAL SIZE	mm.	PCS / BOX	M2 / BOX	BOX / PLT	M2 / PLT	KG. / PLT
60x60	10	3	1,08	40	43,2	960
59,5x59,5 rett.	10	3	1,062	40	42,48	960
30x60	9	7	1,26	40	50,4	989
29,7x59,5 rett.	9	7	1,24	40	49,60	973
45x45	9	7	1,42	26	36,92	709
29,7x29,7 rett.	9	11	0,97	48	46,56	912
30x30 mosaico	9	11	1	30	30	570

cottoantico | concrete and terracotta effect



COLORI

colours - couleurs - farbe - ЦВЕТА



ocra



rosso



porpora



beige



greige

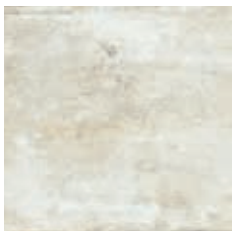

bianco

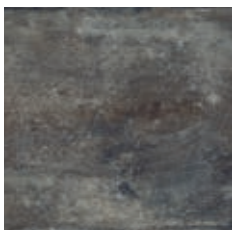

nero

FORMATI

sizes - formats - format - ФОРМАТЫ

naturale



30x60 (12"x24")

≠9



20x40 (8"x16")

≠8,3



20x20 (8"x8")

≠8,3

grip



30x60 (12"x24")

≠9



20x40 (8"x16")

≠8,3



20x20 (8"x8")

≠8,3

SUPERFICI

SURFACE

SURFACE

OBERFLACHE

ПОВЕРХНОСТИ

Naturale

Natural

Naturelle

Matt

Натуральный

Grip

Grip

Grip

Grip

Grip

Grip

Grip



POSA 1/4



FUGA >3 mm



DIN 51130

R11 (GRIP)



DIN 51097

A+B+C (GRIP)

bianco



ocra



30x60 (12"x24")
naturale 65 ●
 7681481 bianco
 7681461 beige
 7681431 ocra
 7681441 rosso
 7681451 greige
 7681471 nero
 7692581 porpora

beige

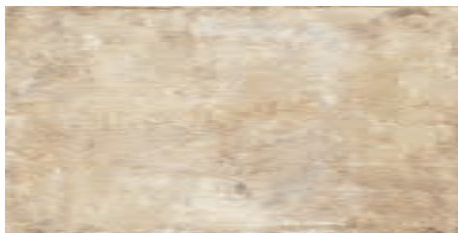

rosso



30x60 (12"x24")
grip 65 ●
 7692531 bianco grip
 7692521 beige grip
 7692561 ocra grip
 7692571 rosso grip
 7692541 greige grip
 7692551 nero grip
 7692591 porpora grip

greige



porpora



20x40 (8"x16")
naturale 66 ●
 7603081 bianco
 7603061 beige
 7603001 ocra
 7603021 rosso
 7603031 greige
 7603071 nero
 7603571 porpora

20x40 (8"x16")
grip 66 ●
 7603551 beige grip
 7603041 ocra grip
 7603051 rosso grip
 7603561 greige grip
 7603581 porpora grip

nero



20x20 (8"x8")
naturale 66 ●
 7603161 bianco
 7603151 beige
 7603101 ocra
 7603111 rosso
 7603121 greige
 7603171 nero
 7603261 porpora

20x20 (8"x8")
grip 66 ●
 7603241 beige grip
 7603131 ocra grip
 7603141 rosso grip
 7603251 greige grip
 7603271 porpora grip

mosaico 5x5 (2"x2") 124 ●



30x30 (12"x12")
7692901 bianco



30x30 (12"x12")
7692881 beige



30x30 (12"x12")
7692871 greige



30x30 (12"x12")
7692891 nero

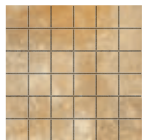

30x30 (12"x12")
7692851 ocra



30x30 (12"x12")
7692861 rosso



30x30 (12"x12")
7692911 porpora

ocra retrò (7 soggetti)



inscatolamento
automatico casuale
random pack up

20x40 (8"x16")
7603091

66 ● 18 ☐

rosso retrò (7 soggetti)



inscatolamento
automatico casuale
random pack up

20x40 (8"x16")
7603521

66 ● 18 ☐

PEZZI SPECIALI trims - pieces speciales - formstücke - СОБЫЕЭЛЕМЕНТЫ



battiscopa naturale

6,5x40 (2,6"x16")

- 7603063 beige
- 7603083 bianco
- 7603033 greige
- 7603073 nero
- 7603003 ocra
- 7603573 porpora
- 7603023 rosso

16 ▲ 22 ☐

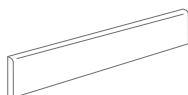

battiscopa naturale

7,5x60 (3"x24")

- 7681462 beige
- 7681482 bianco
- 7681452 greige
- 7681472 nero
- 7681432 ocra
- 7692582 porpora
- 7681442 rosso

24 ▲ 14 ☐

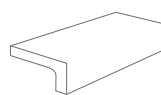

elemento elle pressa grip

15x30x3,5 (6"x12"x1,4")

- 7692523 beige grip
- 7692533 bianco grip
- 7692543 greige grip
- 7692563 ocra grip
- 7692593 porpora grip
- 7692573 rosso grip

44 ▲ 8 ☐

IMBALLI packing - emballages - verpackung - УПАКОВКА

F.TO NOMINALE / NOMINAL SIZE	mm.	PCS / BOX	M2 / BOX	BOX / PLT	M2 / PLT	KG. / PLT
30x60	9	7	1,26	40	50,40	989
20x40	8,3	18	1,44	56	80,64	1359
20x20	8,3	30	1,20	68	81,60	1375
30x30 mosaico	9	11	1,00	-	-	-
20x40 retrò	8,3	18	1,44	-	-	-

cotto cemento - concrete and terracotta effect



cottocemento

COLORI

colours - couleurs - farbe - ЦВЕТА

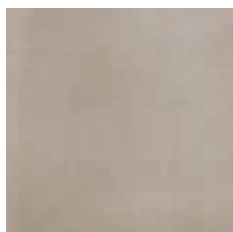

greige

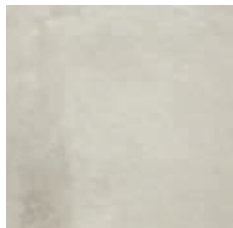

ghiaccio

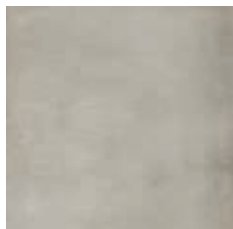

cenere

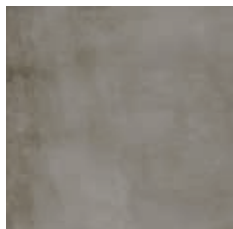

grigio

FORMATI

sizes - formats - format - ФОРМАТЫ

nat/sat

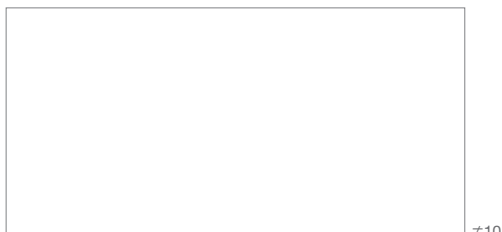

75,5x151,2 (30"X60") RETTIFICATO



75,5x75,5 (30"X30") RETTIFICATO



37,5x75,5 (15"X30") RETTIFICATO



59,5x59,5 (24"X24") RETTIFICATO



30x60 (12"X24") NATURALE
29,7x59,5 (12"X24") RETTIFICATO



45x45 (18"X18") NATURALE



29,7x29,7 (12"X12") RETTIFICATO

grip



45x45 (18"X18") NATURALE

SUPERFICI
SURFACE
SURFACE
OBERFLACHE
ПОВЕРХНОСТИ

Naturale
Natural
Naturelle
Matt
Натуральный

Satinato
Honed
Satinato
Satinato
Satinato

Grip
Grip
Grip
Grip
Grip



POSA 1/4



FUGA 2 mm
PER RETTIFICATO



FUGA >3 mm
PER NATURALE



DIN 51130
R11 (GRIP)



DIN 51097
A+B+C (GRIP)

60x60 NAT U4P4+E3C2
45x45 NAT U4P4E3C2
30x60 NAT U4P3E3C2

greige



mosaico 5x5 (2"x2") 124 ●

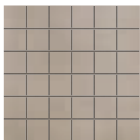

30x30 (12"x12")
7679855 nat.

nat/sat



75,5x151,2 (30"x60")
7690319 nat. rett. 102 ●
7690359 sat. rett. 108 ●



75,5x75,5 (30"x30")
7690039 nat. rett. 87 ●
7690119 sat. rett. 96 ●



37,5x75,5 (15"x30")
7690097 nat. rett. 87 ●
7690149 sat. rett. 96 ●



59,5x59,5 (24"x24")
7687565 nat. rett. 81 ●
7687695 sat. rett. 88 ●



30x60 (12"x24")
7679185 nat. 68 ●

29,7x59,5 (12"x24")
7687605 nat. rett. 78 ●
7687735 sat. rett. 86 ●



45x45 (18"x18")
7665085 nat. 62 ●



29,7x29,7 (12"x12")
7687645 nat. rett. 78 ●
7687775 sat. rett. 86 ●

grip



45x45 (18"x18")
7666525 grip 62 ●

ghiaccio



mosaico 5x5 (2"x2") 124 ●



30x30 (12"x12")
7679865 nat.

mosaico mix 2,2x2,2 (0,87"x0,87") 144 ●

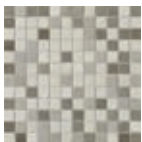

30x30 (12"x12")
7687965 mosaico cen/ghi/gri mix

nat/sat



75,5x151,2 (30"x60")
7690309 nat. rett. 102 ●
7690349 sat. rett. 108 ●



75,5x75,5 (30"x30")
7690029 nat. rett. 87 ●
7690109 sat. rett. 96 ●



37,5x75,5 (15"x30")
7690098 nat. rett. 87 ●
7690139 sat. rett. 96 ●



59,5x59,5 (24"x24")
7687575 nat. rett. 81 ●
7687685 sat. rett. 88 ●



30x60 (12"x24")
7679175 nat. 68 ●

29,7x59,5 (12"x24")
7687615 nat. rett. 78 ●
7687725 sat. rett. 86 ●



45x45 (18"x18")
7665095 nat. 62 ●



29,7x29,7 (12"x12")
7687675 nat. rett. 78 ●
7687765 sat. rett. 86 ●

grip



45x45 (18"x18")
7666635 grip 62 ●

cottocemento

cottocemento | concrete and terracotta effect

cenere



mosaico 5x5 (2"x2") 124 ●



30x30 (12"x12")
7679875 nat.

mosaico mix 2,2x2,2 (0,87"x0,87") 144 ●



30x30 (12"x12")
7687965 mosaico cen/ghi/gri mix

nat/sat

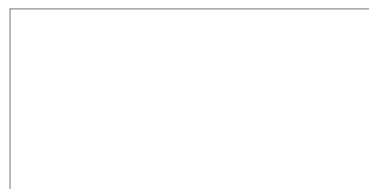

75,5x151,2 (30"x60")
7690299 nat. rett. 102 ●
7690339 sat. rett. 108 ●



75,5x75,5 (30"x30")
7690019 nat. rett. 87 ●
7690099 sat. rett. 96 ●



37,5x75,5 (15"x30")
7690095 nat. rett. 87 ●
7690129 sat. rett. 96 ●



59,5x59,5 (24"x24")
7687585 nat. rett. 81 ●
7687715 sat. rett. 88 ●



30x60 (12"x24")
7679165 nat. 68 ●

29,7x59,5 (12"x24")
7687625 nat. rett. 78 ●
7687755 sat. rett. 86 ●



45x45 (18"x18")
7666005 nat. 62 ●



29,7x29,7 (12"x12")
7687655 nat. rett. 78 ●
7687795 sat. rett. 86 ●

grip



45x45 (18"x18")
7666535 grip 62 ●

grigio



mosaico 5x5 (2"x2") 124 ●



30x30 (12"x12")
7679885 nat.

mosaico mix 2,2x2,2 (0,87"x0,87") 144 ●



30x30 (12"x12")
7687965 mosaico cen/ghi/gri mix

nat/sat

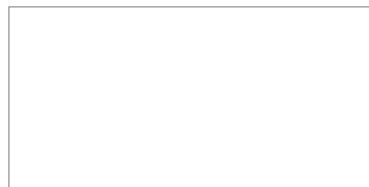

75,5x151,2 (30"x60")
7690289 nat. rett. 102 ●
7690329 sat. rett. 108 ●

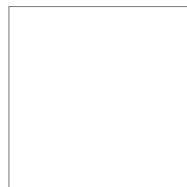

75,5x75,5 (30"x30")
7690009 nat. rett. 87 ●
7690089 sat. rett. 96 ●



37,5x75,5 (15"x30")
7690096 nat. rett. 87 ●
7690159 sat. rett. 96 ●



59,5x59,5 (24"x24")
7687595 nat. rett. 81 ●
7687705 sat. rett. 88 ●



30x60 (12"x24")
7679195 nat. 68 ●

29,7x59,5 (12"x24")
7687635 nat. rett. 78 ●
7687745 sat. rett. 86 ●



45x45 (18"x18")
7666015 nat. 62 ●



29,7x29,7 (12"x12")
7687665 nat. rett. 78 ●
7687785 sat. rett. 86 ●

grip



45x45 (18"x18")
7666625 grip 62 ●

cottocemento

cottocemento | concrete and terracotta effect

vintage (6 soggetti)



59,5x59,5 (24"x24")

7687955 vintage naturale rett.

7687975 vintage satinato rett.

102 ●

112 ●

Do not match with greige color
Non abbinabile al colore greige



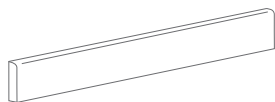

battiscopa naturale

7,5x60 (3"x24")

7681715 greige nat.
7687835 ghiaccio nat.
7687845 cenere nat.
7687855 grigio nat.

24 ▲ 14 ◻

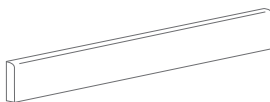

battiscopa naturale rett.

7,5x59,5 (3"x24")

7681705 greige nat. rett.
7687805 ghiaccio nat. rett.
7687815 cenere nat. rett.
7687825 grigio nat. rett.

24 ▲ 14 ◻



battiscopa naturale

9x45 (3,5"x18")

7666086 greige nat.
7666096 ghiaccio nat.
7666006 cenere nat.
7666016 grigio nat.

18 ▲ 12 ◻



*** gradone CR rett.**

33,3x59,5 (13"x24")

7687716 greige rett.
7687836 ghiaccio rett.
7687846 cenere rett.
7687856 grigio rett.

119 ▲ 4 ◻



*** angolare CR SX rett.**

33,3x59,5 (13"x24")

7687718 greige rett.
7687838 ghiaccio rett.
7687848 cenere rett.
7687858 grigio rett.

130 ▲ 2 ◻

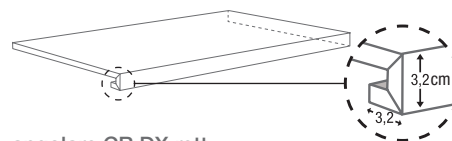

*** angolare CR DX rett.**

33,3x59,5 (13"x24")

7687717 greige rett.
7687837 ghiaccio rett.
7687847 cenere rett.
7687857 grigio rett.

130 ▲ 2 ◻

IMBALLI packing - emballages - verpackung - УПАКОВКА

F.TO NOMINALE / NOMINAL SIZE	mm.	PCS / BOX	M2 / BOX	BOX / PLT	M2 / PLT	KG. / PLT
75,5x151,2 rett.	10	2	2,28	22	50,16	1153,68
75,5x75,5 rett.	10	2	1,14	42	47,88	1138,2
37,5x75,5 rett.	10	4	1,14	45	51,30	1219,5
59,5x59,5 rett.	10	3	1,062	40	42,48	960
30x60	9	7	1,26	40	50,40	989
29,7x59,5 rett.	9	7	1,24	40	49,60	973
45x45	9	7	1,42	26	36,92	707,2
29,7x29,7 rett.	9	11	0,97	48	46,56	912
30x30 mosaico	9	11	1	-	-	-

ferrocemento | concrete and terracotta effect



COLORI

colours - couleurs - farbe - ЦВѢТА



bianco



grigio

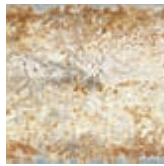

lamiera



beige

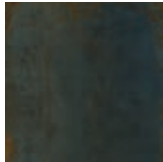

nero



rame

FORMATI TILE+

sizes - formats - format - ФОРМАТЫ



ONLY: Grigio

160x320 (63"x126") RETTIFICATO $\neq 12$

160x320 (63"x126") NON RETTIFICATO

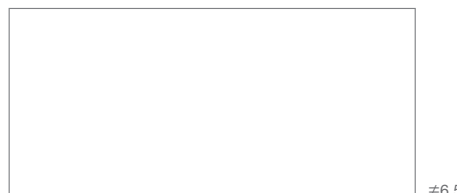

120x260 (47"x102") RETTIFICATO $\neq 6,5$



120x241 (47"x96") RETTIFICATO $\neq 6,5$



120x120 (47"x47") RETTIFICATO $\neq 6,5$



60x120 (24"x47") RETTIFICATO $\neq 6,5$



POSA 1/4



FUGA 2 mm
PER RETTIFICATO



FUGA >3 mm
PER NATURALE

ferrocemento

COLORI

colours - couleurs - farbe - ЦВѢТА



bianco



grigio



lamiera

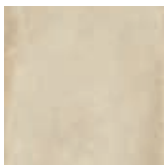

beige

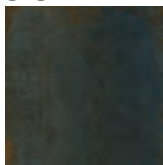

nero



rame

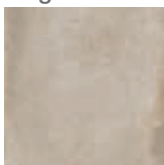

fango



antracite

FORMATI STANDARD

sizes - formats - format - ФОРМАТЫ

nat/lapp



60x120 (24"x47") RETTIFICATO $\neq 10$

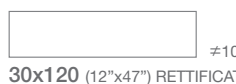

30x120 (12"x47") RETTIFICATO $\neq 10$



59,5x59,5 (24"x24") RETTIFICATO $\neq 10$

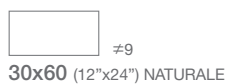

30x60 (12"x24") NATURALE $\neq 9$

29,7x59,5 (12"x24") RETTIFICATO

grip



59,5x59,5 (24"x24") RETTIFICATO $\neq 10$

ONLY: Beige
Grigio - Antracite

SUPERFICI
SURFACE
SURFACE
OBERFLACHE
ПОВЕРХНОСТИ

Naturale

Natural

Naturelle

Matt

Натуральный

Lappato

Semi-Polished

Lappato

Halbpoliert

Полуполированный

Grip

Grip

Grip

Grip

Grip

rame



ferrocemento | concrete and terracotta effect

ferrocemento+ TILE+ PREMIUM SLABS



≠6,5

120x260 (47"x102")
T600345 nat. rett. 118 ●



≠6,5

120x241 (47"x96")
T610895 nat. rett. 118 ●



≠6,5

120x120 (47"x47")
T610875 nat. rett. 108 ●



≠6,5

60x120 (24"x47")
T610915 nat. rett. 108 ●

ferrocemento STANDARD



≠10

60x120 (24"x47")
7649345 nat. rett. 91 ●
7649775 lapp. rett. 99 ●



≠10

30x120 (12"x47")
7649505 nat. rett. 91 ●
7649825 lapp. rett. 99 ●



≠10

59,5x59,5 (24"x24")
7649555 nat. rett. 81 ●
7691565 lapp. rett. 88 ●



≠9

30x60 (12"x24")
7681465 nat. 68 ●

29,7x59,5 (12"x24")
7692035 nat. rett. 78 ●
7693115 lapp. rett. 86 ●

mosaico 5x5 (2"x2") 124 ●



30x30 (12"x12")
7692615 nat.
7693245 lapp.

listellato 131 ●



30x60 (12"x24")
7692665 nat.
7693195 lapp.

nero



ferrocemento+
TILE+
PREMIUM SLABS

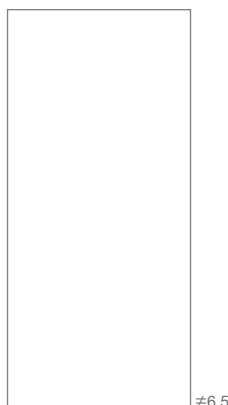

120x260 (47"x102")
T600355 nat. rett. 118 ●

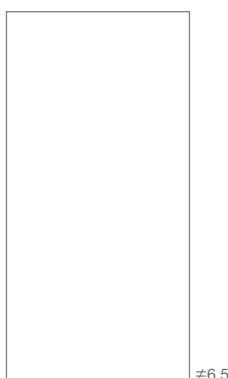

120x241 (47"x96")
T610905 nat. rett. 118 ●



120x120 (47"x47")
T610885 nat. rett. 108 ●



60x120 (24"x47")
T610925 nat. rett. 108 ●

ferrocemento
STANDARD



60x120 (24"x47")
7649335 nat. rett. 91 ●
7649765 lapp. rett. 99 ●



30x120 (12"x47")
7649495 nat. rett. 91 ●
7649815 lapp. rett. 99 ●



59,5x59,5 (24"x24")
7649545 nat. rett. 81 ●
7691555 lapp. rett. 88 ●



30x60 (12"x24")
7681455 nat. 68 ●

29,7x59,5 (12"x24")
7692025 nat. rett. 78 ●
7693105 lapp. rett. 86 ●

mosaico 5x5 (2"x2") 124 ●



30x30 (12"x12")
7692605 nat.
7693235 lapp.

listellato 131 ●



30x60 (12"x24")
7692655 nat.
7693185 lapp.

ferrocemento | concrete and terracotta effect

beige



ferrocemento | concrete and terracotta effect

ferrocemento+
TILE+
PREMIUM SLABS

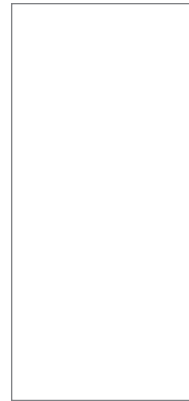

≠6,5

120x260 (47"x102")
T600405 nat. rett. **118 ●**



≠6,5

120x241 (47"x96")
T611025 nat. rett. **118 ●**

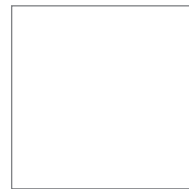

≠6,5

120x120 (47"x47")
T610995 nat. rett. **108 ●**



≠6,5

60x120 (24"x47")
T611055 nat. rett. **108 ●**

ferrocemento
STANDARD



≠10

60x120 (24"x47")
7649375 nat. rett. **91 ●**
7649785 lapp. rett. **99 ●**



≠10

30x120 (12"x47")
7649535 nat. rett. **91 ●**
7649835 lapp. rett. **99 ●**



≠10

59,5x59,5 (24"x24")
7649575 nat. rett. **81 ●**
7691585 lapp. rett. **88 ●**



≠9

30x60 (12"x24")
7692005 nat. **68 ●**

29,7x59,5 (12"x24")
7692055 nat. rett. **78 ●**
7693135 lapp. rett. **86 ●**

grip



≠10

59,5x59,5 (24"x24")
7694415 grip rett. **81 ●**

mosaico 5x5 (2"x2") **124 ●**



30x30 (12"x12")
7692635 nat.
7693205 lapp.

listellato **131 ●**



30x60 (12"x24")
7692685 nat.
7693155 lapp.

grigio



ferrocemento+ TILE+ PREMIUM SLABS



160x320 (63"x126")
T616206 nat. rett. **131 ●**
T616205 nat. N/rett. **127 ●**



120x260 (47"x102")
T600415 nat. rett. **118 ●**



120x241 (47"x96")
T611035 nat. rett. **118 ●**



120x120 (47"x47")
T611005 nat. rett. **108 ●**



60x120 (24"x47")
T611065 nat. rett. **108 ●**

ferrocemento STANDARD



60x120 (24"x47")
7649365 nat. rett. **91 ●**
7649795 lapp. rett. **99 ●**



30x120 (12"x47")
7649515 nat. rett. **91 ●**
7649845 lapp. rett. **99 ●**



59,5x59,5 (24"x24")
7649565 nat. rett. **81 ●**
7691575 lapp. rett. **88 ●**



30x60 (12"x24")
7681475 nat. **68 ●**

29,7x59,5 (12"x24")
7692045 nat. rett. **78 ●**
7693125 lapp. rett. **86 ●**

grip



59,5x59,5 (24"x24")
7694395 grip rett. **81 ●**

mosaico 5x5 (2"x2") **124 ●**



30x30 (12"x12")
7692625 nat.
7693225 lapp.

listellato **131 ●**



30x60 (12"x24")
7692675 nat.
7693175 lapp.

bianco



ferrocemento | concrete and terracotta effect

ferrocemento+ TILE+ PREMIUM SLABS

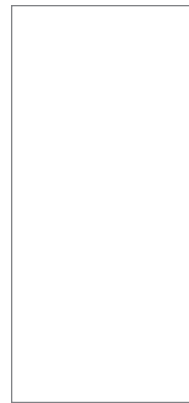

≠6,5

120x260 (47"x102")
T600395 nat. rett. **118 ●**



≠6,5

120x241 (47"x96")
T611015 nat. rett. **118 ●**

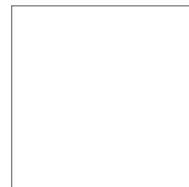

≠6,5

120x120 (47"x47")
T610985 nat. rett. **108 ●**



≠6,5

60x120 (24"x47")
T611045 nat. rett. **108 ●**

ferrocemento STANDARD



≠10

60x120 (24"x47")
7649385 nat. rett. **91 ●**
7649805 lapp. rett. **99 ●**



≠10

30x120 (12"x47")
7649525 nat. rett. **91 ●**
7649855 lapp. rett. **99 ●**



≠10

59,5x59,5 (24"x24")
7649585 nat. rett. **81 ●**
7691595 lapp. rett. **88 ●**



≠9

30x60 (12"x24")
7692015 nat. **68 ●**

29,7x59,5 (12"x24")
7692065 nat. rett. **78 ●**
7693145 lapp. rett. **86 ●**

mosaico 5x5 (2"x2") **124 ●**



30x30 (12"x12")
7692645 nat.
7693215 lapp.

listellato **131 ●**



30x60 (12"x24")
7692695 nat.
7693165 lapp.

lamiera



ferrocemento+ TILE+ PREMIUM SLABS

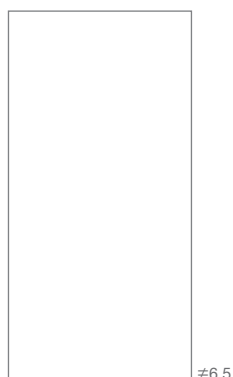

120x241 (47"x96")
T613155 nat. rett. 118 ●

ferrocemento STANDARD



60x120 (24"x47")
7651125 nat. rett. 91 ●

fango



ferrocemento STANDARD



≠10

60x120 (24"x47")

7649905 nat. rett. 91 ●

7649925 lapp. rett. 99 ●



≠10

30x120 (12"x47")

7649945 nat. rett. 91 ●

7649965 lapp. rett. 99 ●



≠10

59,5x59,5 (24"x24")

7691755 nat. rett. 81 ●

7691775 lapp. rett. 88 ●



≠9

30x60 (12"x24")

7693265 nat. 68 ●

29,7x59,5 (12"x24")

7693285 nat. rett. 78 ●

7693305 lapp. rett. 86 ●

mosaico 5x5 (2"x2") 124 ●



30x30 (12"x12")

7693325 nat.

7693565 lapp.

listellato 131 ●



30x60 (12"x24")

7693345 nat.

7693555 lapp.

antracite

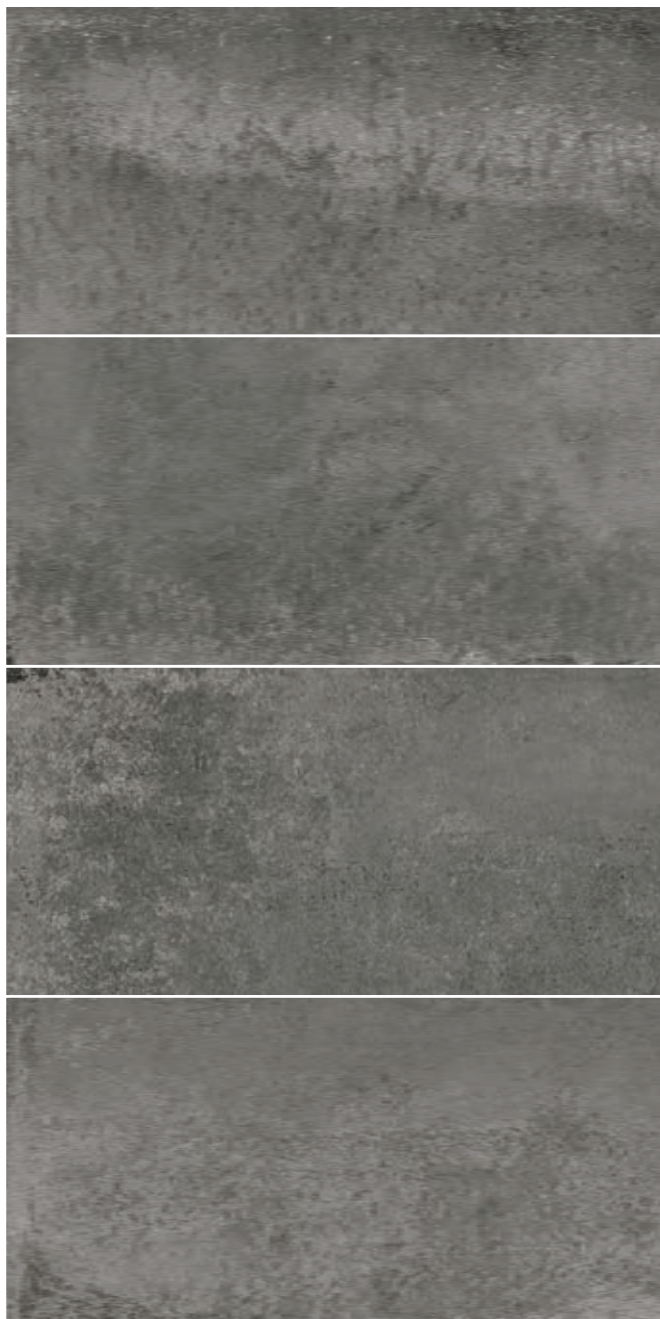

ferrocemento STANDARD



≠10

60x120 (24"x47")

7649895 nat. rett. 91 ●

7649915 lapp. rett. 99 ●



≠10

30x120 (12"x47")

7649935 nat. rett. 91 ●

7649955 lapp. rett. 99 ●



≠10

59,5x59,5 (24"x24")

7691745 nat. rett. 81 ●

7691765 lapp. rett. 88 ●



≠9

30x60 (12"x24")

7693255 nat. 68 ●

29,7x59,5 (12"x24")

7693275 nat. rett. 78 ●

7693295 lapp. rett. 86 ●

grip



≠10

59,5x59,5 (24"x24")

7694405 grip rett. 81 ●

mosaico 5x5 (2"x2") 124 ●



30x30 (12"x12")

7693315 nat.

7693545 lapp.

listellato 131 ●



30x60 (12"x24")

7693335 nat.

7693535 lapp.

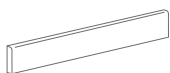

battiscopa naturale #10
7,5x60 (3"x24")

7693515 antracite nat.
7692006 beige nat.
7692016 bianco nat.
7693525 fango nat.
7681476 grigio nat.
7681456 nero nat.
7681466 rame nat.

24 ▲ 14 ◻

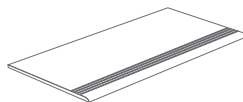

gradino step naturale #9
30x60 (12"x24")

7693395 antracite nat.
7692007 beige nat.
7692017 bianco nat.
7693405 fango nat.
7681477 grigio nat.
7681457 nero nat.
7681467 rame nat.

48 ▲ 7 ◻

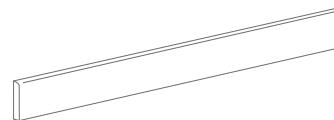

battiscopa rettificato #10
10x120 (4"x47")

7693495 antracite rett.
7649536 beige rett.
7649386 bianco rett.
7693505 fango rett.
7649366 grigio rett.
7649336 nero rett.
7649346 rame rett.
7651128 lamiera rett.

48 ▲ 4 ◻

battiscopa rettificato #10
7,5x59,5 (3"x24")

7693475 antracite rett.
7692056 beige rett.
7692066 bianco rett.
7693485 fango rett.
7692046 grigio rett.
7692026 nero rett.
7692036 rame rett.

24 ▲ 14 ◻

gradino step rettificato #9
29,7x59,5 (12"x24")

7693375 antracite rett.
7692057 beige rett.
7692067 bianco rett.
7693385 fango rett.
7692047 grigio rett.
7692027 nero rett.
7692037 rame rett.

48 ▲ 7 ◻

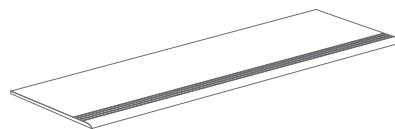

gradino step rettificato #10
30x120 (12"x47")

7693355 antracite rett.
7649537 beige rett.
7649538 bianco rett.
7693365 fango rett.
7649539 grigio rett.
7649541 nero rett.
7649543 rame rett.

106 ▲ 4 ◻

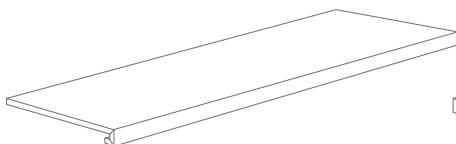

* **gradone CR rett.** #10
33,3x120 (13"x47")

7693455 antracite rett.
7649377 beige rett.
7649387 bianco rett.
7693465 fango rett.
7649367 grigio rett.
7649337 nero rett.
7649347 rame rett.

142 ▲ 2 ◻

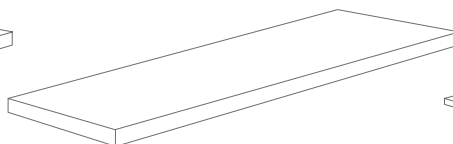

* **angolare CR SX rett.** #10
33,3x120 (13"x47")

7693445 antracite rett.
7649379 beige rett.
7649389 bianco rett.
7693445 fango rett.
7649369 grigio rett.
7649339 nero rett.
7649349 rame rett.

147 ▲ 2 ◻

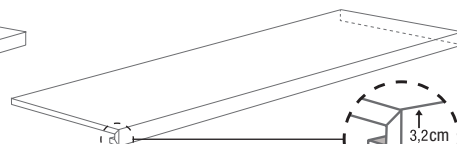







* **angolare CR DX rett.** #10
33,3x120 (13"x47")

7693425 antracite rett.
7649378 beige rett.
7649388 bianco rett.
7693425 fango rett.
7649368 grigio rett.
7649338 nero rett.
7649348 rame rett.

147 ▲ 2 ◻

TILE+ PREMIUM SLABS	F.TO NOMINALE / NOMINAL SIZE	mm.	TIPOLOGIA IMBALLO / PACKAGING		LASTRA / SLAB			CASSA - CAVALLETTO / CRATE - A-FRAME			
			ARTICOLO / ITEM	DIMENSIONE / SIZE	PCS	M2	KG	PCS	M2	KG VUOTO/EMPTY	KG TOT
160x320	rett. - N/rett.	12	1 cavalletto / A-frame 	75x330x194h	1	5,12	150	20	102,4	193	3193
		12	2 cassa / crate 	175x345x37h	1	5,12	150	9	46,08	163	1513
120x260	rett.	6,5	3 cassa / crate 	136x284x38h	1	3,12	48,4	20	62,4	95	1063
120x241	rett.	6,5		136x264x38h	1	2,89	44,6	20	57,8	90	982

TILE+ PREMIUM SLABS	F.TO NOMINALE / NOMINAL SIZE	mm.	TIPOLOGIA IMBALLO / PACKAGING						
			ARTICOLO / ITEM	DIMENSIONE / SIZE	PCS / BOX	M2 / BOX	BOX / PLT	M2 / PLT	KG. / PLT
120x120	rett.	6,5	pallet con sponda	123x143	2	2,88	24	69,12	1070
60x120	rett.	6,5	pallet	95x122	3	2,16	36	77,76	1204,2

STANDARD		mm.					
F.TO NOMINALE / NOMINAL SIZE							
60x120	rett.	10	2	1,44	36	51,84	1152
30x120	rett.	10	3	1,08	20	21,60	480
59,5x59,5	rett.	10	3	1,062	40	42,48	960
30x60		9	7	1,26	40	50,40	989
29,7x59,5	rett.	9	7	1,24	40	49,60	973
30x30	mosaico	9	11	1	-	-	-
30x60	listellato	9	4	0,72	-	-	-

¹ I cavalletti vengono sempre addebitati al costo di € 250,00

A-frames are always charged at a cost of €250.00
 Die Transportböcke werden zum Preis von € 250,00 berechnet.
 Les chevalets sont toujours livrés à un coût de 250,00 €
 За подставки всегда взимается плата в размере 250,00 €

² Nel caso di piccole forniture il materiale verrà consegnato in casse addebitate al costo di € 160,00

In the case of small orders the material will be shipped in crates charged at a cost of €160.00
 Bei kleinen Lieferungen wird das Material in Kisten ausgeliefert, die zum Preis von € 160,00 berechnet werden.
 En cas de petites fournitures, le matériel sera livré dans des caisses ayant un coût de 160,00 €
 В случае маленьких поставок материал будет доставляться в ящиках стоимостью 160,00 €

³ Per casse complete con un unico articolo la cassa viene fornita gratuita. Per vendite inferiori alla cassa completa la cassa viene addebitata al costo di € 70,00

If a crate is complete and contains one single item the crate is supplied free of charge. If a crate is not complete the crate is charged at a cost of €70.00
 Bei kompletten Kisten, die einen einzigen Artikel enthalten, wird die Kiste nicht berechnet. Bei Verkäufen nicht kompletter Kisten werden die Kisten zum Preis von € 70,00 berechnet.
 Pour des caisses remplies avec un seul article, celles-ci seront fournies gratuitement. Pour des ventes qui ne remplissent pas la caisse, celle-ci est vendue à un prix de 70,00 €
 Ящики, заполненные полностью одним артикулом, поставляются бесплатно. При продаже количества меньше одного полного ящика взимается плата в размере 70,00 € за ящик



COLORI

colours - couleurs - farbe - ЦВЕТА



cream



taupe



grey

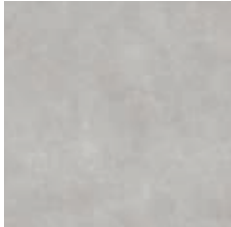

silver

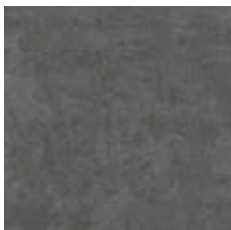

smoke

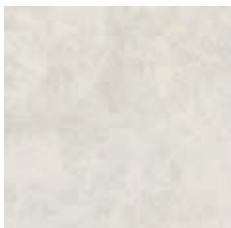

white

FORMATI TILE+

sizes - formats - format - ФОРМАТЫ



120x260 (47"x102") RETTIFICATO #6,5

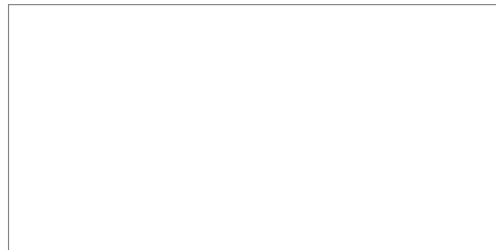

120x241 (47"x96") RETTIFICATO #6,5

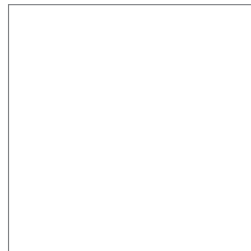

120x120 (47"x47") RETTIFICATO #6,5



60x120 (24"x47") RETTIFICATO #6,5



POSA 1/4



FUGA 2 mm
PER RETTIFICATO



FUGA >3 mm
PER NATURALE



DIN 51130
R11 (GRIP)



DIN 51097
A+B+C (GRIP)

global | concrete and terracotta effect

global

FORMATI STANDARD

sizes - formats - format - ФОРМАТЫ

naturale



59,5x59,5 (24"x24") RETTIFICATO #9



29,7x59,5 (12"x24") RETTIFICATO #9

grip



29,7x59,5 (12"x24") RETTIFICATO #9

SUPERFICI
SURFACE
SURFACE
OBERFLACHE
ПОВЕРХНОСТИ

Naturale

Natural

Naturelle

Matt

Натуральный

Grip Outdoor

Grip Outdoor

Grip Outdoor

Grip Outdoor

Grip Outdoor

white



global | concrete and terracotta effect

global+
TILE+
PREMIUM SLABS

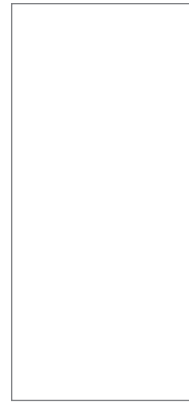

±6,5

120x260 (47"x102")
T600205 nat. rett.

118 ●



±6,5

120x241 (47"x96")
T610605 nat. rett.

118 ●

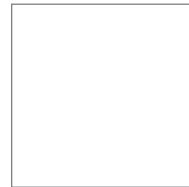

±6,5

120x120 (47"x47")
T610675 nat. rett.

108 ●



±6,5

60x120 (24"x47")
T610735 nat. rett.

108 ●

global
STANDARD



±9

59,5x59,5 (24"x24")
7691495 nat. rett.

76 ●



±9

29,7x59,5 (12"x24")
7693035 nat. rett.

76 ●

grip



±9

29,7x59,5 (12"x24")
7694355 grip rett.

76 ●

mosaico 5x5 (2"x2") 124 ●



30x30 (12"x12")
7693095

silver



global+ TILE+ PREMIUM SLABS



120x260 (47"x102")
T600215 nat. rett. 118 ●



120x241 (47"x96")
T610615 nat. rett. 118 ●

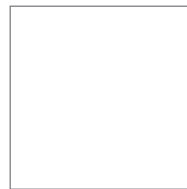

120x120 (47"x47")
T610685 nat. rett. 108 ●



60x120 (24"x47")
T610745 nat. rett. 108 ●

global STANDARD



59,5x59,5 (24"x24")
7691505 nat. rett. 76 ●



29,7x59,5 (12"x24")
7693005 nat. rett. 76 ●

grip



29,7x59,5 (12"x24")
7694325 grip rett. 76 ●

mosaico 5x5 (2"x2") 124 ●



30x30 (12"x12")
7693065

grey

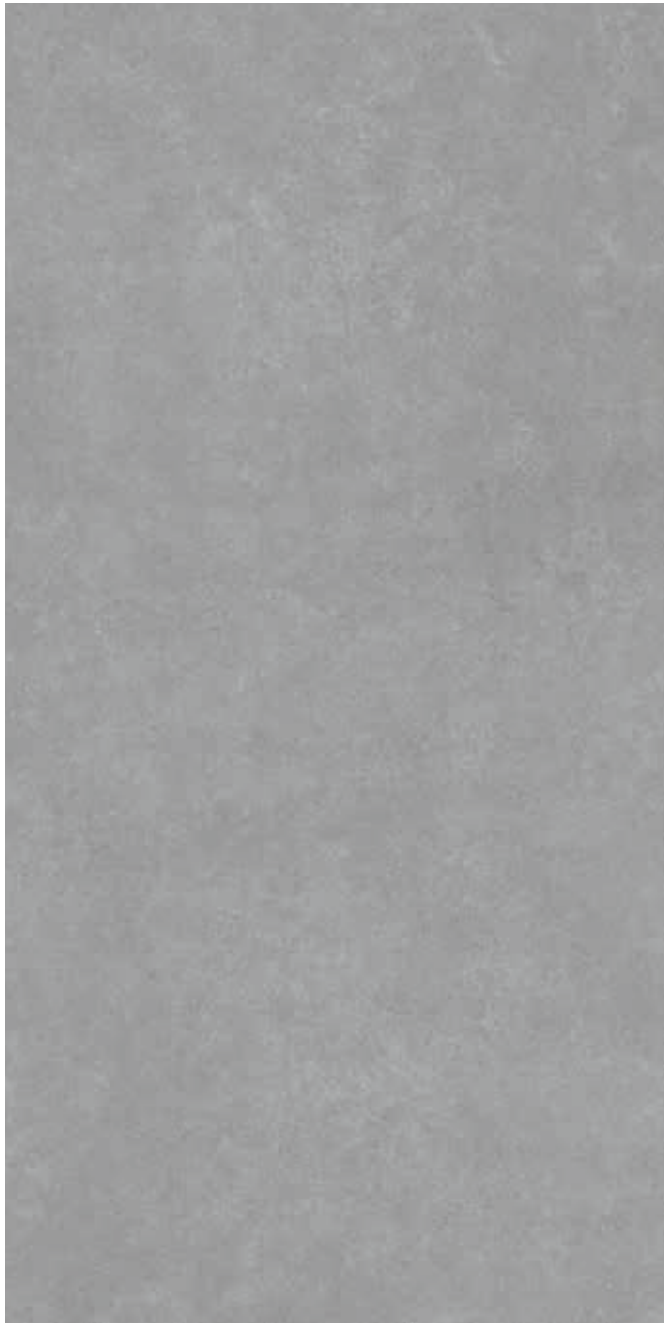

global | concrete and terracotta effect

global+
TILE+
PREMIUM SLABS

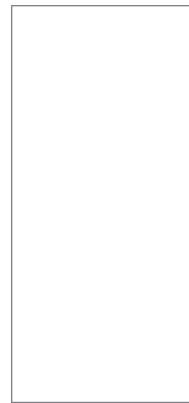

±6,5

120x260 (47"x102")
T600255 nat. rett.

118 ●



±6,5

120x241 (47"x96")
T610665 nat. rett.

118 ●



±6,5

120x120 (47"x47")
T610725 nat. rett.

108 ●



±6,5

60x120 (24"x47")
T610785 nat. rett.

108 ●

global
STANDARD



±9

59,5x59,5 (24"x24")
7691545 nat. rett.

76 ●



±9

29,7x59,5 (12"x24")
7692995 nat. rett.

76 ●

grip



±9

29,7x59,5 (12"x24")
7694315 grip rett.

76 ●

mosaico 5x5 (2"x2") 124 ●



30x30 (12"x12")
7693055

smoke



global+
TILE+
PREMIUM SLABS

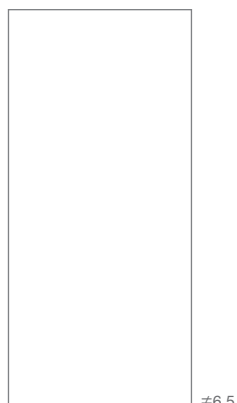

120x260 (47"x102")
T600245 nat. rett. 118 ●

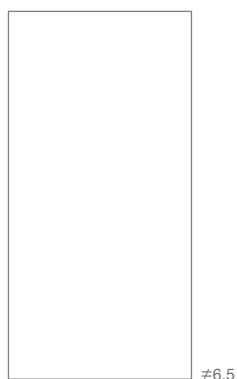

120x241 (47"x96")
T610645 nat. rett. 118 ●



120x120 (47"x47")
T610715 nat. rett. 108 ●



60x120 (24"x47")
T610775 nat. rett. 108 ●

global
STANDARD



59,5x59,5 (24"x24")
7691535 nat. rett. 76 ●



29,7x59,5 (12"x24")
7693015 nat. rett. 76 ●

grip



29,7x59,5 (12"x24")
7694335 grip rett. 76 ●

mosaico 5x5 (2"x2") 124 ●



30x30 (12"x12")
7693075

global | concrete and terracotta effect

cream



global | concrete and terracotta effect

global+
TILE+
PREMIUM SLABS



±6,5

120x260 (47"x102")
T600235 nat. rett.

118 ●



±6,5

120x241 (47"x96")
T610635 nat. rett.

118 ●



±6,5

120x120 (47"x47")
T610705 nat. rett.

108 ●



±6,5

60x120 (24"x47")
T610765 nat. rett.

108 ●

global
STANDARD



±9

59,5x59,5 (24"x24")
7691525 nat. rett.

76 ●



±9

29,7x59,5 (12"x24")
7692985 nat. rett.

76 ●

grip



±9

29,7x59,5 (12"x24")
7694305 grip rett.

76 ●

mosaico 5x5 (2"x2") **124 ●**



30x30 (12"x12")
7693045

taupe



global+ TILE+ PREMIUM SLABS



≠6,5

120x260 (47"x102")
T600225 nat. rett. 118 ●



≠6,5

120x241 (47"x96")
T610625 nat. rett. 118 ●



≠6,5

120x120 (47"x47")
T610695 nat. rett. 108 ●



≠6,5

60x120 (24"x47")
T610755 nat. rett. 108 ●

global STANDARD



≠9

59,5x59,5 (24"x24")
7691515 nat. rett. 76 ●



≠9

29,7x59,5 (12"x24")
7693025 nat. rett. 76 ●

grip



≠9

29,7x59,5 (12"x24")
7694345 grip rett. 76 ●

mosaico 5x5 (2"x2") 124 ●



30x30 (12"x12")
7693085

PEZZI SPECIALI trims - pieces speciales - formstücke - СОБИЕЭЛЕМЕНТЫ

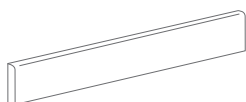

battiscopa rettificato #9
7,5x59,5 (3"x24")
 7692987 cream rett.
 7692997 grey rett.
 7693007 silver rett.
 7693017 smoke rett.
 7693027 taupe rett.
 7693037 white rett.

24 ▲ 14 ◻

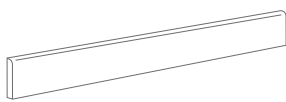

battiscopa rett. #6,5
10x120 (4"x47")
 T610766 cream rett.
 T910786 grey rett.
 T610746 silver rett.
 T610776 smoke rett.
 T610756 taupe rett.
 T610736 white rett.

48 ▲ 6 ◻

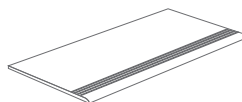



gradino step rettificato #9
29,7x59,5 (12"x24")
 7692986 cream rett.
 7692996 grey rett.
 7693006 silver rett.
 7693016 smoke rett.
 7693026 taupe rett.
 7693036 white rett.

48 ▲ 7 ◻

IMBALLI packing - emballages - verpackung - УПАКОВКА

TILE+ PREMIUM SLABS	F.TO NOMINALE / NOMINAL SIZE	mm.	TIPOLOGIA IMBALLO / PACKAGING		LASTRA / SLAB			CASSA - CAVALLETTO / CRATE - A-FRAME			
			ARTICOLO / ITEM	DIMENSIONE / SIZE	PCS	M2	KG	PCS	M2	KG VUOTO/EMPTY	KG TOT
120x260	rett.	6,5	*cassa / crate	136x284x38h	1	3,12	48,4	20	62,4	95	1063
120x241	rett.	6,5		136x264x38h	1	2,89	44,6	20	57,8	90	982

TILE+ PREMIUM SLABS	F.TO NOMINALE / NOMINAL SIZE	mm.	TIPOLOGIA IMBALLO / PACKAGING						
			ARTICOLO / ITEM	DIMENSIONE / SIZE	PCS / BOX	M2 / BOX	BOX / PLT	M2 / PLT	KG. / PLT
120x120	rett.	6,5	pallet con sponda	123x143	2	2,88	24	69,12	1070
60x120	rett.	6,5	pallet	95x122	3	2,16	36	77,76	1204,2

STANDARD		mm.	PCS / BOX	M2 / BOX	BOX / PLT	M2 / PLT	KG. / PLT
F.TO NOMINALE / NOMINAL SIZE							
59,5x59,5	rett.	9	3	1,062	40	42,48	833
29,7x59,5	rett.	9	7	1,24	40	49,60	973
30x30	mosaico	9	11	1	-	-	-

* Per casse complete con un unico articolo la cassa viene fornita gratuita. Per vendite inferiori alla cassa completa la cassa viene addebitata al costo di € 70,00

If a crate is complete and contains one single item the crate is supplied free of charge. If a crate is not complete the crate is charged at a cost of €70.00

Bei kompletten Kisten, die einen einzigen Artikel enthalten, wird die Kiste nicht berechnet. Bei Verkäufen nicht kompletter Kisten werden die Kisten zum Preis von € 70,00 berechnet.

Pour des caisses remplies avec un seul article, celles-ci seront fournies gratuitement. Pour des ventes qui ne remplissent pas la caisse, celle-ci est vendue à un prix de 70,00 €

3 Ящики, заполненные полностью одним артикулом, поставляются бесплатно. При продаже количества меньше одного полного ящика взимается плата в размере 70,00 € за ящик



laredo | concrete and terracotta effect

beige



33,3x33,3 (13"x13") 60 ●
7643670 naturale
7656171 grip

oro



33,3x33,3 (13"x13") 60 ●
7654170 naturale
7656181 grip

rosa



33,3x33,3 (13"x13") 60 ●
7654200 naturale
7656201 grip

ocra



33,3x33,3 (13"x13") 60 ●
7643660 naturale
7656191 grip

SUPERFICI
SURFACE
SURFACE
OBERFLACHE
ПОВЕРХНОСТИ

Naturale

Natural
Naturelle
Matt

Натуральный

Grip

Grip

Grip

Grip

Grip

Grip

GS

V3



FUGA >3 mm



DIN 51130
R11 (GRIP)



DIN 51097
B (GRIP)

PEZZI SPECIALI

trims - pieces speciales - formstücke - собыеэлементы



battiscopa
8x33,3 (3,2"x13")
7621299 beige
7621309 ocra
7621019 oro
7621238 rosa

12 ▲ 32 ◻

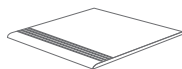

gradino step
33,3x33,3 (13"x13")
7643710 beige
7643700 ocra
7654180 oro
7654210 rosa

35 ▲ 13 ◻

IMBALLI packing - emballages - verpackung - УПАКОВКА

F.TO NOMINALE / NOMINAL SIZE	mm.	PCS / BOX	M2 / BOX	BOX / PLT	M2 / PLT	KG. / PLT
33,3x33,3	8	14	1,55	44	68,20	1100



COLORI

colours - couleurs - farbe - ЦВЕТА



beige

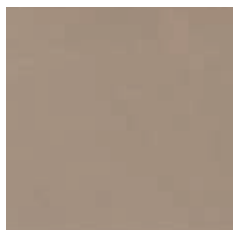

camel

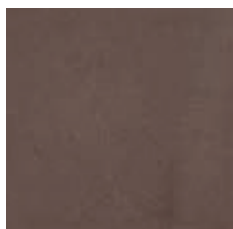

marrone

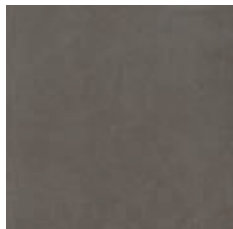

moro



bianco



grigio



nero

FORMATI

sizes - formats - format - ФОРМАТЫ



60x60 (24"x24") $\neq 10$



30x60 (12"x24") $\neq 9$



45x45 (18"x18") $\neq 9$



33,3x33,3 (13"x13") $\neq 7,5$



POSA 1/4



FUGA >3 mm

bianco



beige



moro



grigio

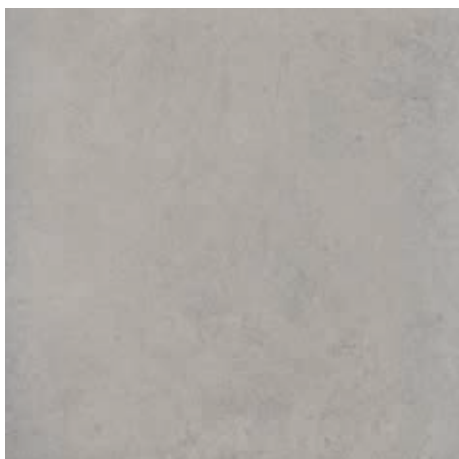

camel



nero



marrone



logica | concrete and terracotta effect



60x60 (24"x24") **68** ●
 7684365 beige
 7685405 camel
 7684395 marrone
 7684375 bianco
 7684385 grigio
 7684405 nero
 7685395 moro



45x45 (18"x18") **60** ●
 7690116 beige
 7690226 camel
 7690146 marrone
 7690106 bianco
 7690126 grigio
 7690136 nero
 7690215 moro



30x60 (12"x24") **60** ●
 7667955 beige
 7675365 camel
 7667985 marrone
 7667945 bianco
 7667965 grigio
 7667975 nero
 7675355 moro



33,3x33,3 (13"x13") **54** ●
 7662736 beige
 7662926 camel
 7662806 marrone
 7662726 bianco
 7662746 grigio
 7662792 nero
 7662916 moro

mosaico 5x5 (2"x2") 122 ●

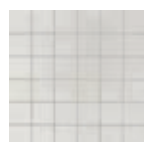

30x30 (12"x12")
 7669765 bianco

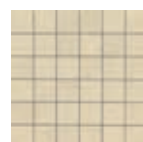

30x30 (12"x12")
 7669755 beige



30x30 (12"x12")
 7675375 moro

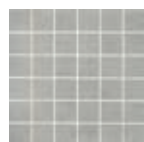

30x30 (12"x12")
 7669775 grigio

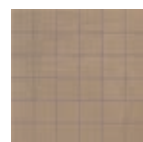

30x30 (12"x12")
 7675385 camel



30x30 (12"x12")
 7669795 nero



30x30 (12"x12")
 7669785 marrone

PEZZI SPECIALI trims - pieces speciales - formstücke - СОБЫЕЭЛЕМЕНТЫ

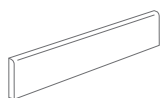

battiscopa
8x45 (3,2"x18")
 7690186 bianco
 7690196 grigio
 7690166 nero
 7690176 beige
 7690246 camel
 7690237 moro
 7690206 marrone

18 ▲ 12 ◻

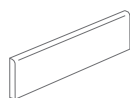

battiscopa
8x33,3 (3,2"x13")
 7662815 bianco
 7662835 grigio
 7662845 nero
 7662825 beige
 7662965 camel
 7662955 moro
 7662855 marrone

8 ▲ 32 ◻

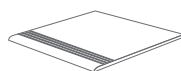

gradino step
33,3x33,3 (13"x13")
 7662865 bianco
 7662885 grigio
 7662905 nero
 7662875 beige
 7662945 camel
 7662935 moro
 7662895 marrone

30 ▲ 13 ◻

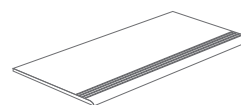

gradino step
30x60 (12"x24")
 7666778 grigio
 7666777 nero
 7666776 beige
 7666775 moro
 7666773 marrone

53 ▲ 7 ◻

IMBALLI packing - emballages - verpackung - УПАКОВКА

F.TO NOMINALE / NOMINAL SIZE	mm.	PCS / BOX	M2 / BOX	BOX / PLT	M2 / PLT	KG. / PLT
60x60	10	3	1,08	40	43,2	930
30x60	9	7	1,26	40	50,40	1000
45x45	9	7	1,42	52	73,84	1274
33,3x33,3	7,5	13	1,44	44	63,36	969
30x30 mosaico	9	11	1	32	32	643,20



COLORI

colours - couleurs - farbe - ЦВЕТА



sand



rust



silver



shell

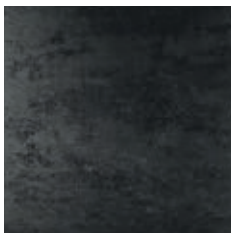

smoke

FORMATI

sizes - formats - format - ФОРМАТЫ



≠10

59,5x59,5 (24"x24") RETTIFICATO



≠9

30x60 (12"x24") NATURALE
29,7x59,5 (12"x24") RETTIFICATO



≠9

14,8x59,5 (6"x24") RETTIFICATO



≠9

45x45 (18"x18") NATURALE
44,5x44,5 (18"x18") RETTIFICATO



≠9

29,7x29,7 (12"x12") RETTIFICATO



POSA 1/4



FUGA >3 mm
PER NATURALE



DIN 51130
R9

shell



sand



59,5x59,5 (24"x24") 81 ●
 7680191 sand nat. rett.
 7680201 rust nat. rett.
 7680181 shell nat. rett.
 7680171 smoke nat. rett.
 7688735 silver nat. rett.

silver



rust



30x60 (12"x24") 70 ●
 7660521 sand nat.
 7660501 rust nat.
 7660491 shell nat.
 7660511 smoke nat.
 7677721 silver nat.

29,7x59,5 (12"x24") 80 ●
 7662341 sand nat. rett.
 7662351 rust nat. rett.
 7662331 shell nat. rett.
 7662321 smoke nat. rett.
 7679491 silver nat. rett.



14,8x59,5 (6"x24") 87 ●
 7663041 sand nat. rett.
 7663031 rust nat. rett.
 7663051 shell nat. rett.
 7662791 smoke nat. rett.
 7679521 silver nat. rett.

smoke



45x45 (18"x18") 62 ●
 7656131 sand nat.
 7656111 rust nat.
 7656101 shell nat.
 7656121 smoke nat.
 7663405 silver nat.

44,5x44,5 (18"x18") 76 ●
 7650361 sand nat. rett.
 7650371 rust nat. rett.
 7650351 shell nat. rett.
 7650341 smoke nat. rett.
 7664005 silver nat. rett.



29,7x29,7 (12"x12") 80 ●
 7663071 sand nat. rett.
 7663061 rust nat. rett.
 7663081 shell nat. rett.
 7663091 smoke nat. rett.
 7679501 silver nat. rett.

mosaico 2x2 (0,8"x0,8") 142 ●

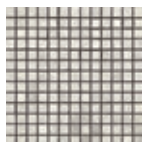

29,7x29,7 (12"x12")
7636681 shell rett.

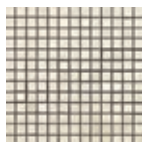

29,7x29,7 (12"x12")
7636691 sand rett.

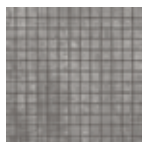

29,7x29,7 (12"x12")
7664015 silver rett.

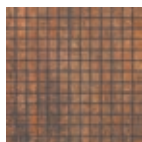

29,7x29,7 (12"x12")
7636701 rust rett.



29,7x29,7 (12"x12")
7636671 smoke rett.

righe (preinciso) 118 ●



29,7x59,5 (12"x24")
7662721 shell rett.



29,7x59,5 (12"x24")
7662731 sand rett.



29,7x59,5 (12"x24")
7679511 silver rett.



29,7x59,5 (12"x24")
7662741 rust rett.

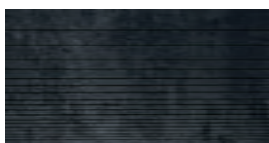

29,7x59,5 (12"x24")
7662711 smoke rett.

PEZZI SPECIALI trims - pieces speciales - formstücke - СОБИЕЭЛЕМЕНТЫ

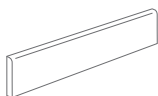

battiscopa naturale
9x45 (3,5"x18")
7650461 smoke naturale
7650441 sand naturale
7650431 rust naturale
7650451 shell naturale
7664065 silver naturale

18 ▲ 12 ◻

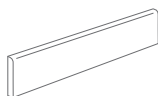

battiscopa rett.
9x44,5 (3,5"x18")
7651965 smoke rett.
7651945 sand rett.
7651935 rust rett.
7651955 shell rett.
7664075 silver rett.

18 ▲ 12 ◻

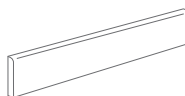

battiscopa naturale
7,5x60 (3"x24")
7662661 smoke naturale
7662641 sand naturale
7662631 rust naturale
7662651 shell naturale
7688745 silver naturale

34 ▲ 14 ◻

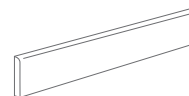

battiscopa rett.
7,5x59,5 (3"x24")
7666409 smoke rett.
7666419 sand rett.
7666429 rust rett.
7666430 shell rett.
7688755 silver rett.

34 ▲ 14 ◻

IMBALLI packing - emballages - verpackung - УПАКОВКА

F.TO NOMINALE / NOMINAL SIZE	mm.	PCS / BOX	M2 / BOX	BOX / PLT	M2 / PLT	KG. / PLT
59,5x59,5 rett.	10	3	1,062	40	42,48	960
45x45	9	7	1,42	26	36,92	720,2
44,5x44,5 rett.	9	7	1,39	26	36,14	655,20
30x60	9	7	1,26	40	50,4	989
29,7x59,5 rett.	9	7	1,24	40	49,6	973
14,8x59,5 rett.	9	14	1,23	40	49,2	1000
29,7x29,7 rett.	9	11	0,97	48	46,56	912
29,7x29,7 mosaico	9	11	0,97	32	31,04	608



neutral | concrete and terracotta effect

COLORI

colours - couleurs - farbe - ЦВЕТА



bianco



tortora

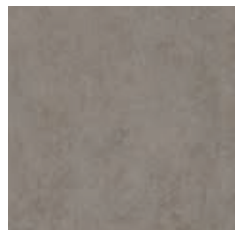

piombo

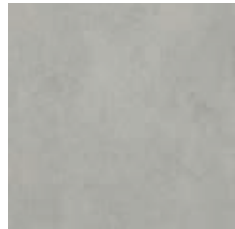

grigio

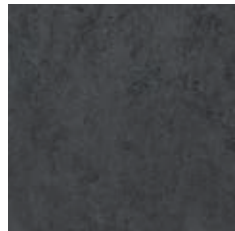

nero

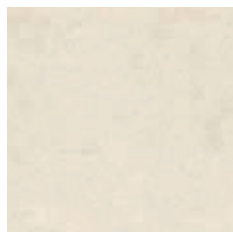

latte

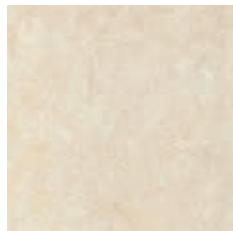

avorio

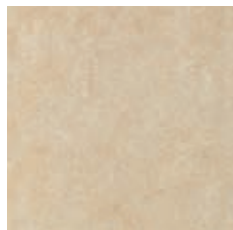

beige



ecrù



marrone

FORMATI

sizes - formats - format - ФОРМАТЫ

naturale - lappato

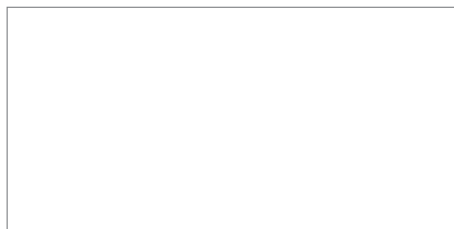

≠10

60x120 (24"x47") RETTIFICATO



≠10

59,5x59,5 (24"x24") RETTIFICATO



≠9

30x60 (12"x24") NATURALE
29,7x59,5 (12"x24") RETTIFICATO



≠9

45x45 (18"x18") NATURALE
44,5x44,5 (18"x18") RETTIFICATO



30x30 (12"x12") NATURALE ≠8
29,7x29,7 (12"x12") RETTIFICATO ≠9

grip

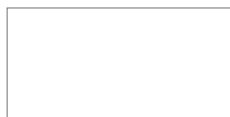

≠9

30x60 (12"x24") NATURALE
29,7x59,5 (12"x24") RETTIFICATO

> pag. 232

ROC 2CM

60,5x60,5 (24"x24") RETT.

SUPERFICI
SURFACE
SURFACE
OBERFLACHE
ПОВЕРХНОСТИ

Naturale
Natural
Naturelle
Matt
Натуральный

Lappato
Semi-Polished
Lappato
Halbpoliert
Полуполированный

Grip
Grip
Grip
Grip
Grip



POSA 1/4



FUGA 2 mm
PER RETTIFICATO



FUGA >3 mm
PER NATURALE



DIN 51130
R11 (GRIP)



DIN 51097
A+B+C (GRIP)



U4P4+E3C2



U4P4E3C2



U4P3E3C2

tortora

piombo

grigio



neutra | concrete and terracotta effect

naturale/lappato

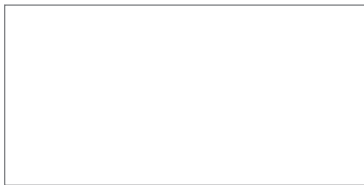

60x120 (24"x47")

naturale rettificato 91 ●

- 7648715 tortora nat. rett.
- 7648735 piombo nat. rett.
- 7648725 grigio nat. rett.
- 7648745 nero nat. rett.
- 7648685 bianco nat. rett.

lappato rettificato 99 ●

- 7648785 tortora lapp. rett.
- 7648805 piombo lapp. rett.
- 7648795 grigio lapp. rett.
- 7648815 nero lapp. rett.
- 7648755 bianco lapp. rett.



59,5x59,5 (24"x24")

naturale rettificato 81 ●

- 7684355 tortora nat. rett.
- 7684345 piombo nat. rett.
- 7684325 grigio nat. rett.
- 7684335 nero nat. rett.
- 7690335 bianco nat. rett.

lappato rettificato 88 ●

- 7685325 tortora lapp. rett.
- 7685315 piombo lapp. rett.
- 7685275 grigio lapp. rett.
- 7685305 nero lapp. rett.
- 7690325 bianco lapp. rett.



45x45 (18"x18")

naturale 62 ●

- 7652181 tortora nat.
- 7652201 piombo nat.
- 7652191 grigio nat.
- 7652211 nero nat.
- 7679595 bianco nat.

44,5x44,5 (18"x18")

naturale rettificato 76 ●

- 7652675 tortora nat. rett.
- 7652665 piombo nat. rett.
- 7652625 grigio nat. rett.
- 7652655 nero nat. rett.
- 7679605 bianco nat. rett.

lappato rettificato 85 ●

- 7652735 tortora lapp. rett.
- 7652725 piombo lapp. rett.
- 7652685 grigio lapp. rett.
- 7652715 nero lapp. rett.
- 7679615 bianco lapp. rett.



30x30 (12"x12")

naturale 62 ●

- 7666721 tortora nat.
- 7666751 piombo nat.
- 7666761 grigio nat.
- 7666791 nero nat.
- 7679581 bianco nat.

29,7x29,7 (12"x12")

naturale rettificato 78 ●

- 7670191 tortora nat. rett.
- 7670171 piombo nat. rett.
- 7670181 grigio nat. rett.
- 7670161 nero nat. rett.
- 7679651 bianco nat. rett.

lappato rettificato 86 ●

- 7675341 tortora lapp. rett.
- 7675331 piombo lapp. rett.
- 7675291 grigio lapp. rett.
- 7675321 nero lapp. rett.
- 7679661 bianco lapp. rett.

nero



bianco



neutra

mosaico 5x5 (2"x2") 124 ●



30x30 (12"x12")
7670231 tortora



30x30 (12"x12")
7670221 piombo

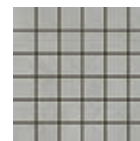

30x30 (12"x12")
7670201 grigio



30x30 (12"x12")
7670211 nero



30x30 (12"x12")
7679671 bianco

neutra | concrete and terracotta effect

grip



30x60 (12"x24")

naturale 68 ●

7669881 tortora nat.
7669861 piombo nat.
7669871 grigio nat.
7669851 nero nat.
7679621 bianco nat.

29,7x59,5 (12"x24")

naturale rettificato 78 ●

7670151 tortora nat. rett.
7670131 piombo nat. rett.
7670141 grigio nat. rett.
7670121 nero nat. rett.
7679641 bianco nat. rett.

lappato rettificato 86 ●

7675281 tortora lapp. rett.
7675271 piombo lapp. rett.
7675231 grigio lapp. rett.
7675261 nero lapp. rett.
7679631 bianco lapp. rett.



30x60 (12"x24")

grip 68 ●

7681201 tortora grip
7673101 piombo grip
7673091 grigio grip
7681211 nero grip
7681225 bianco grip

29,7x59,5 (12"x24")

grip rettificato 78 ●

7681331 tortora grip rett.
7681311 piombo grip rett.
7681301 grigio grip rett.
7681341 nero grip rett.
7681351 bianco grip rett.

latte

ecrù

marrone



neutra | concrete and terracotta effect

naturale/lappato



60x120 (24"x47")

naturale rettificato 91 ●

- 7692275 latte nat. rett.
- 7692255 ecrù nat. rett.
- 7692265 marrone nat. rett.
- 7648695 avorio nat. rett.
- 7648705 beige nat. rett.

lappato rettificato 99 ●

- 7649615 latte lapp. rett.
- 7649595 ecrù lapp. rett.
- 7649605 marrone lapp. rett.
- 7648765 avorio lapp. rett.
- 7648775 beige lapp. rett.



59,5x59,5 (24"x24")

naturale rettificato 81 ●

- 7691225 latte nat. rett.
- 7691205 ecrù nat. rett.
- 7691215 marrone nat. rett.
- 7684305 avorio nat. rett.
- 7684315 beige nat. rett.

lappato rettificato 88 ●

- 7691255 latte lapp. rett.
- 7691235 ecrù lapp. rett.
- 7691245 marrone lapp. rett.
- 7685285 avorio lapp. rett.
- 7685295 beige lapp. rett.



45x45 (18"x18")

naturale 62 ●

- 7666415 latte nat.
- 7666395 ecrù nat.
- 7666405 marrone nat.
- 7652231 avorio nat.
- 7652221 beige nat.

44,5x44,5 (18"x18")

naturale rettificato 76 ●

- 7666445 latte nat. rett.
- 7666425 ecrù nat. rett.
- 7666435 marrone nat. rett.
- 7652635 avorio nat. rett.
- 7652645 beige nat. rett.

lappato rettificato 85 ●

- 7666505 latte lapp. rett.
- 7666485 ecrù lapp. rett.
- 7666495 marrone lapp. rett.
- 7652695 avorio lapp. rett.
- 7652705 beige lapp. rett.



30x30 (12"x12")

naturale 62 ●

- 7692211 latte nat.
- 7692191 ecrù nat.
- 7692201 marrone nat.
- 7666711 avorio nat.
- 7666731 beige nat.

29,7x29,7 (12"x12")

naturale rettificato 78 ●

- 7692391 latte nat. rett.
- 7692371 ecrù nat. rett.
- 7692381 marrone nat. rett.
- 7670411 avorio nat. rett.
- 7670401 beige nat. rett.

lappato rettificato 86 ●

- 7692421 latte lapp. rett.
- 7692401 ecrù lapp. rett.
- 7692411 marrone lapp. rett.
- 7675301 avorio lapp. rett.
- 7675311 beige lapp. rett.

avorio



beige



neutra

mosaico 5x5 (2"x2") 124 ●

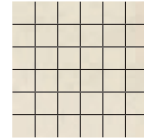

30x30 (12"x12")
7692451 latte

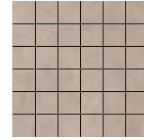

30x30 (12"x12")
7692431 ecrù

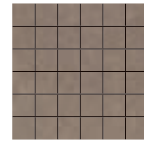

30x30 (12"x12")
7692441 marrone



30x30 (12"x12")
7670431 avorio



30x30 (12"x12")
7670421 beige



30x60 (12"x24")
naturale 68 ●
7692301 latte nat.
7692281 ecrù nat.
7692291 marrone nat.
7670371 avorio nat.
7670361 beige nat.

29,7x59,5 (12"x24")
naturale rettificato 78 ●
7692331 latte nat. rett.
7692311 ecrù nat. rett.
7692321 marrone nat. rett.
7670391 avorio nat. rett.
7670381 beige nat. rett.

lappato rettificato 86 ●
7692361 latte lapp. rett.
7692341 ecrù lapp. rett.
7692351 marrone lapp. rett.
7675241 avorio lapp. rett.
7675251 beige lapp. rett.

grip



30x60 (12"x24")
grip 68 ●
7692481 latte grip
7692461 ecrù grip
7692471 marrone grip
7673111 avorio grip
7681231 beige grip

29,7x59,5 (12"x24")
grip rettificato 78 ●
7692511 latte grip rett.
7692491 ecrù grip rett.
7692501 marrone grip rett.
7681321 avorio grip rett.
7681361 beige grip rett.

PEZZI SPECIALI trims - pieces speciales - formstücke - СОБЫЕЭЛЕМЕНТЫ

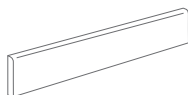

battiscopa naturale

7,5x60 (3"x24")

7670591 grigio naturale
7670631 avorio naturale
7670621 beige naturale
7670611 nero naturale
7670601 piombo naturale
7670581 tortora naturale
7679642 bianco naturale
7692303 latte naturale
7692283 ecrù naturale
7692293 marrone naturale

24 ▲ 14 ◻



battiscopa naturale

9x45 (3,5"x18")

7652241 grigio naturale
7652361 avorio naturale
7652341 beige naturale
7652331 nero naturale
7652321 piombo naturale
7652301 tortora naturale
7679644 bianco naturale
7666416 latte naturale
7666396 ecrù naturale
7666406 marrone naturale

21 ▲ 12 ◻

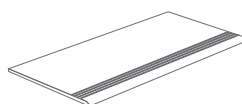

gradino step naturale

30x60 (12"x24")

7674427 grigio naturale
7674428 avorio naturale
7674426 beige naturale
7674424 nero naturale
7674429 piombo naturale
7674423 tortora naturale
7679645 bianco naturale
7692304 latte naturale
7692284 ecrù naturale
7692294 marrone naturale

48 ▲ 7 ◻

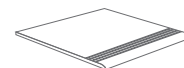

gradino step naturale

30x30 (12"x12")

7666567 grigio naturale
7666737 avorio naturale
7666577 beige naturale
7666597 nero naturale
7666753 piombo naturale
7666747 tortora naturale
7666587 bianco naturale
7692212 latte naturale
7692192 ecrù naturale
7692202 marrone naturale

30 ▲ 11 ◻

battiscopa rett.

7,5x59,5 (3"x24")

7670651 grigio rett.
7670691 avorio rett.
7670681 beige rett.
7670671 nero rett.
7670661 piombo rett.
7670641 tortora rett.
7679643 bianco rett.
7692334 latte rett.
7692313 ecrù rett.
7692322 marrone rett.

24 ▲ 14 ◻

gradino step rett.

29,7x59,5 (12"x24")

7674432 grigio rett.
7674430 avorio rett.
7674425 beige rett.
7674433 nero rett.
7674434 piombo rett.
7674435 tortora rett.
7679646 bianco rett.
7692335 latte rett.
7692314 ecrù rett.
7692323 marrone rett.

48 ▲ 7 ◻

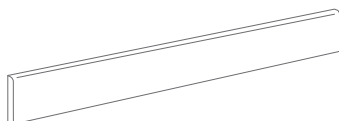







battiscopa rett.

10x120 (4"x47")

7648726 grigio rett.
7648697 avorio rett.
7648706 beige rett.
7648746 nero rett.
7648736 piombo rett.
7648716 tortora rett.
7648686 bianco rett.
7692276 latte rett.
7692256 ecrù rett.
7692266 marrone rett.

48 ▲ 4 ◻

IMBALLI packing - emballages - verpackung - УПАКОВКА

F.TO NOMINALE / NOMINAL SIZE	 mm.	 PCS / BOX	 M2 / BOX	 BOX / PLT	 M2 / PLT	 KG. / PLT
60x120 rett.	10	2	1,44	36	51,84	1152
59,5x59,5 rett.	10	3	1,062	40	42,48	960
30x60	9	7	1,26	40	50,40	989
29,7x59,5 rett.	9	7	1,24	40	49,60	973
45x45	9	7	1,42	26	36,92	720,20
44,5x44,5 rett.	9	7	1,39	26	36,14	655,2
30x30	8	13	1,17	48	56,16	960
29,7x29,7 rett.	9	11	0,97	48	46,56	912
30x30 mosaico	9	11	1	-	-	-



neutra | concrete and



COLORI

colours - couleurs - farbe - ЦВЕТА



bianco

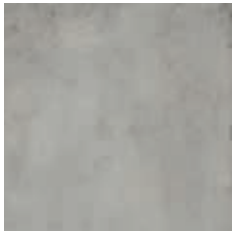

grigio

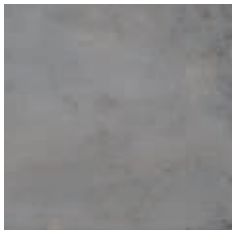

nero



sabbia

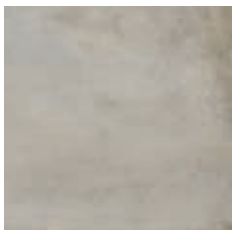

argilla

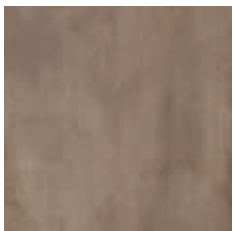

ambra

FORMATI

sizes - formats - format - ФОРМАТЫ



≠10

59,5x59,5 (24"x24") RETTIFICATO



≠9

30x60 (12"x24") NATURALE

29,7x59,5 (12"x24") RETTIFICATO

GM

V2



POSA 1/4



FUGA 2 mm
PER RETTIFICATO



FUGA >3 mm
PER NATURALE

bianco



sabbia



59,5x59,5 (24"x24")

rettificato 81 ●

7690925 bianco rett.

7690955 grigio rett.

7690965 nero rett.

7690935 sabbia rett.

7690945 argilla rett.

7690975 ambra rett.

grigio

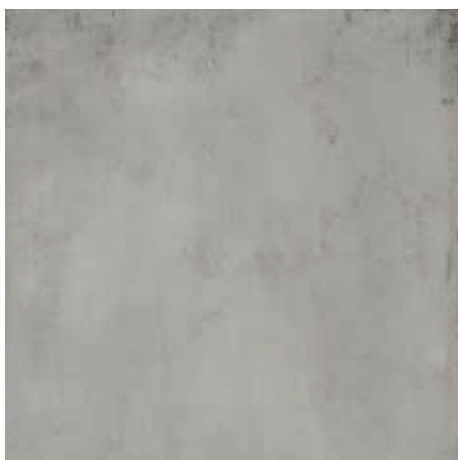

argilla



30x60 (12"x24")

naturale 68 ●

7692075 bianco nat.

7692115 grigio nat.

7692105 nero nat.

7692085 sabbia nat.

7692095 argilla nat.

7692125 ambra nat.

29,7x59,5 (12"x24")

rettificato 78 ●

7692135 bianco rett.

7692175 grigio rett.

7692165 nero rett.

7692145 sabbia rett.

7692155 argilla rett.

7692185 ambra rett.

nero

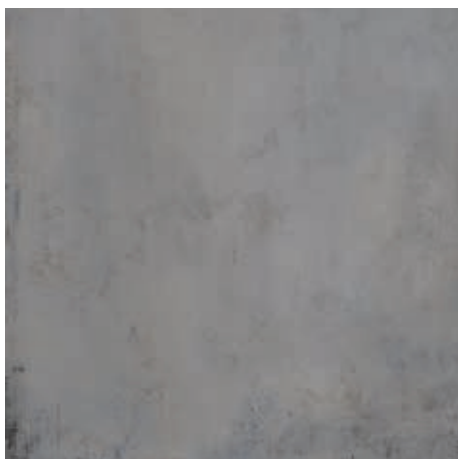

ambra





30x30 (12"x12")
7692705 bianco



30x30 (12"x12")
7692745 grigio



30x30 (12"x12")
7692735 nero



30x30 (12"x12")
7692715 sabbia



30x30 (12"x12")
7692725 argilla

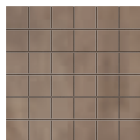

30x30 (12"x12")
7692755 ambra

PEZZI SPECIALI trims - pieces speciales - formstücke - СОБИЕЭЛЕМЕНТЫ

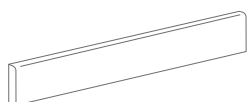

battiscopa naturale

- 7,5x60 (3"x24")
7692126 ambra nat.
7692096 argilla nat.
7692076 bianco nat.
7692116 grigio nat.
7692106 nero nat.
7692086 sabbia nat.

24 ▲ 14 ◻

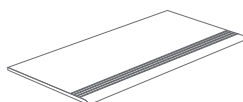

gradino step naturale

- 30x60 (12"x24")
7692127 ambra nat.
7692097 argilla nat.
7692077 bianco nat.
7692117 grigio nat.
7692107 nero nat.
7692087 sabbia nat.

48 ▲ 7 ◻

battiscopa rettificato

- 7,5x59,5 (3"x24")
7692186 ambra rett.
7692156 argilla rett.
7692136 bianco rett.
7692176 grigio rett.
7692166 nero rett.
7692146 sabbia rett.







24 ▲ 14 ◻

gradino step rettificato

- 29,7x59,5 (12"x24")
7692187 ambra rett.
7692157 argilla rett.
7692137 bianco rett.
7692177 grigio rett.
7692167 nero rett.
7692147 sabbia rett.

48 ▲ 7 ◻

IMBALLI packing - emballages - verpackung - УПАКОВКА

F.TO NOMINALE / NOMINAL SIZE	 mm.	 PCS / BOX	 M2 / BOX	 BOX / PLT	 M2 / PLT	 KG. / PLT
59,5x59,5 rett.	10	3	1,062	40	42,48	960
30x60	9	7	1,26	40	50,40	989
29,7x59,5 rett.	9	7	1,24	40	49,60	973
30x30 mosaico	9	11	1	-	-	-

urbandeck | concrete and terracotta effect



COLORI

colours - couleurs - farbe - ЦВЕТА



white



silver



grey



sand



taupe

FORMATI

sizes - formats - format - ФОРМАТЫ

naturale

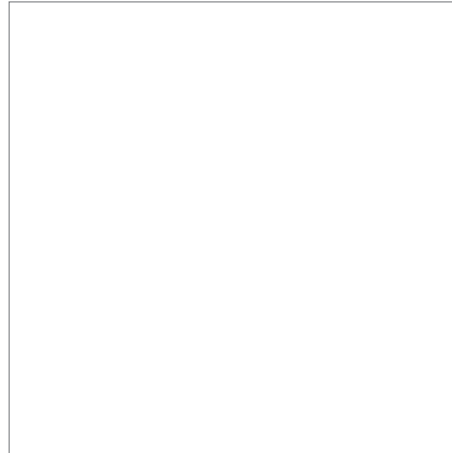

120x120 (47"x47") RETTIFICATO $\neq 10$



60x120 (24"x47") RETTIFICATO $\neq 10$



59,5x59,5 (24"x24") RETTIFICATO $\neq 10$



30x60 (12"x24") NATURALE $\neq 9$
29,7x59,5 (12"x24") RETTIFICATO $\neq 10$

roc



59,5x59,5 (24"x24") RETTIFICATO $\neq 10$



29,7x59,5 (12"x24") RETTIFICATO $\neq 10$

ONLY: White - Silver - Grey

saime

SUPERFICI

SURFACE

SURFACE

OBERFLACHE

ПОВЕРХНОСТИ

Naturale

Natural

Naturelle

Matt

Натуральный

Roc

Roc

Roc

Roc

Roc

Roc



POSA 1/4



FUGA 2 mm
PER RETTIFICATO



FUGA >3 mm
PER NATURALE

> pag. 234

grip 2CM

ONLY: Silver - Grey - Taupe

$\neq 20$

40x120 (16"x47") RETT.

white



silver



grey



naturale

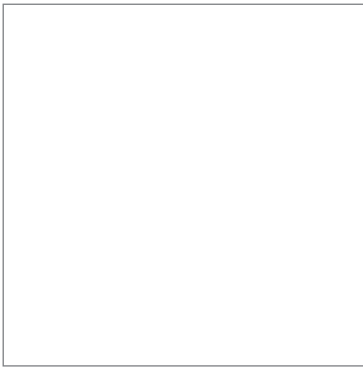

120x120 (47"x47")
rettificato

108 ●

- T612145 grey rett.
- T612285 sand rett.
- T612135 silver rett.
- T612295 taupe rett.
- T612125 white rett.



60x120 (24"x47")
rettificato

91 ●

- T612175 grey rett.
- T612265 sand rett.
- T612165 silver rett.
- T612275 taupe rett.
- T612155 white rett.

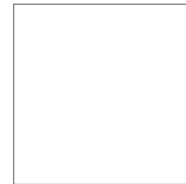

59,5x59,5 (24"x24")
rettificato

81 ●

- T612345 grey rett.
- T612305 sand rett.
- T612335 silver rett.
- T612315 taupe rett.
- T612325 white rett.

sand

taupe

urbandeck



30X60 (12"x24")

naturale #9 68 ●

7693671 grey nat.

7693681 sand nat.

7693691 silver nat.

7693701 taupe nat.

7693711 white nat.

29,7X59,5 (12"x24")

rettificato #10 81 ●

T612395 grey rett.

T612355 sand rett.

T612385 silver rett.

T612365 taupe rett.

T612375 white rett.

roc



59,5X59,5 (24"x24")

roc rettificato #10 81 ●

7694525 grey roc rett.

7694515 silver roc rett.

7694505 white roc rett.



30X60 (12"x24")

roc rettificato #10 81 ●

7694555 grey roc rett.

7694545 silver roc rett.

7694535 white roc rett.

urbandeck | concrete and terracotta effect

mosaico 5x5 (2"x2") #9 124 ●

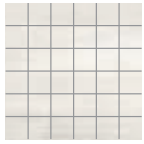

30x30 (12"x12")
7693811 white nat.

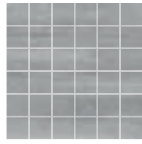

30x30 (12"x12")
7693791 silver nat.

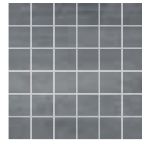

30x30 (12"x12")
7693771 grey nat.



30x30 (12"x12")
7693781 sand nat.

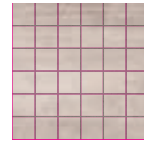

30x30 (12"x12")
7693801 taupe nat.

listellato #10 131 ●



30x60 (12"x24")
7693861 white nat.



30x60 (12"x24")
7693841 silver nat.



30x60 (12"x24")
7693821 grey nat.

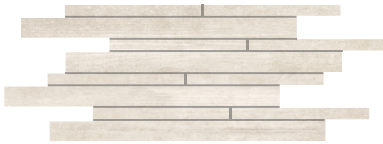

30x60 (12"x24")
7693831 sand nat.



30x60 (12"x24")
7693851 taupe nat.

PEZZI SPECIALI trims - pieces speciales - formstücke - СОБИЕЭЛЕМЕНТЫ

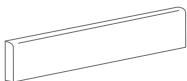

battiscopa naturale
7,5x60 (3"x24")
7693712 white nat.
7693682 sand nat.
7693692 silver nat.
7693702 taupe nat.
7693672 grey nat.

24 ▲ 14 ◻

battiscopa rett.
7,5x59,5 (3"x24")
7693836 white rett.
7693833 sand rett.
7693834 silver rett.
7693835 taupe rett.
7693832 grey rett.

24 ▲ 14 ◻

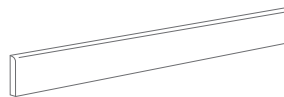

battiscopa rett.
7,5x120 (3"x47")
T612156 white rett.
T612266 sand rett.
T612166 silver rett.
T612276 taupe rett.
T612176 grey rett.

48 ▲ 4 ◻

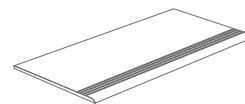

gradino step nat. # 9
30x60 (12"x24")
7693713 white nat.
7693683 sand nat.
7693693 silver nat.
7693703 taupe nat.
7693673 grey nat.

48 ▲ 7 ◻

gradino step rett. #10
29,7x59,5 (12"x24")
7693843 white rett.
7693839 sand rett.
7693840 silver rett.
7693842 taupe rett.
7693837 grey rett.

48 ▲ 7 ◻

IMBALLI packing - emballages - verpackung - УПАКОВКА

F.TO NOMINALE / NOMINAL SIZE	mm.	PCS / BOX	M2 / BOX	BOX / PLT	M2 / PLT	KG. / PLT
120x120 rett.	10	2	2,88	18	51,84	1266
60x120 rett.	10	2	1,44	36	51,84	1130
59,5x59,5 rett.	10	3	1,062	40	42,48	916
30x60	9	7	1,26	40	50,40	989
29,7x59,5 rett.	10	7	1,24	36	44,64	1008
30x30 mosaico	9	11	1,00	-	-	-
30x60 listellato	10	4	0,72	-	-	-

urbandeck

urbandeck | concrete and terracotta effect



valencia | concrete and terracotta effect

COLORI

colours - couleurs - farbe - ЦВЕТА



bone



oro



rosso



grigio



antracite

FORMATI

sizes - formats - format - ФОРМАТЫ

naturale



≠10

60x60 (24"x24")



≠9

45x45 (18"x18")



≠8

33,3x33,3 (13"x13")

grip (corindonato)



≠9

45x45 (18"x18")



≠8

33,3x33,3 (13"x13")

SUPERFICI

SURFACE

SURFACE

OBERFLACHE

ПОВЕРХНОСТИ

Naturale

Natural

Naturelle

Matt

Натуральный

Grip (Corindonato)

Grip

Grip

Grip

Grip

GS

V3



POSA 1/4



FUGA >3 mm



DIN 51130

R10 (GRIP)



DIN 51097

A+B (GRIP)

bone



oro



naturale

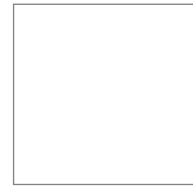

60x60 (24"x24") 70 ●
 7688045 antracite
 7687945 grigio
 7687935 bone



45x45 (18"x18") 60 ●
 7652755 antracite
 7952745 grigio
 7689605 bone
 7689595 oro
 7689585 rosso

grigio



rosso



33,3x33,3 (13"x13") 60 ●
 7657781 antracite
 7657761 grigio
 7644750 bone
 7663581 oro
 7644790 rosso

antracite



grip (corindonato)



45x45 (18"x18") 60 ●
 7652775 antracite cor.
 7652765 grigio cor.
 7689635 bone cor.
 7689625 oro cor.
 7689615 rosso cor.



33,3x33,3 (13"x13") 60 ●
 7657791 antracite cor.
 7657771 grigio cor.
 7666471 bone cor.
 7666461 oro cor.
 7666451 rosso cor.

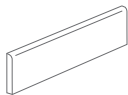

battiscopa
8x33,3 (3,2"x13")
 7621198 bone
 7621218 oro
 7621228 rosso
 7657809 grigio
 7657819 antracite
 12 ▲ 32 ◻

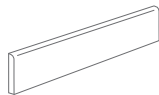

battiscopa
8x45 (3,2"x18")
 7652959 bone
 7652979 oro
 7652989 rosso
 7652969 grigio
 7652949 antracite
 18 ▲ 12 ◻

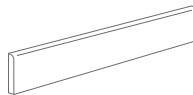

battiscopa
7,5x60 (3"x24")
 7678727 bone
 7678726 grigio
 7678728 antracite
 24 ▲ 14 ◻

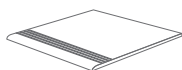

step
33,3x33,3 (13"x13")
 7665582 bone
 7654073 bone cor.
 7663602 oro
 7663603 oro cor.
 7654070 rosso
 7654072 rosso cor.
 7654076 grigio
 7654074 grigio cor.
 7654071 antracite
 7654075 antracite cor.
 35 ▲ 13 ◻

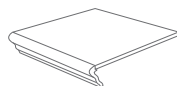



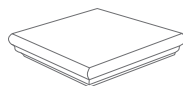



*** gradone**
33,3x33,3 (13"x13")
 7656594 bone
 7658232 bone cor.
 7656634 oro
 7657992 oro cor.
 7656654 rosso
 7658222 rosso cor.
 7656636 grigio
 7657993 grigio cor.
 7656596 antracite
 7658233 antracite cor.
 66 ▲ 6 ◻



*** gradone angolare**
33,3x33,3 (13"x13")
 7656604 bone
 7658262 bone cor.
 7656644 oro
 7658242 oro cor.
 7656664 rosso
 7658252 rosso cor.
 7657996 grigio
 7657994 grigio cor.
 7656597 antracite
 7658263 antracite cor.
 93 ▲ 2 ◻

IMBALLI packing - emballages - verpackung - УПАКОВКА

F.TO NOMINALE / NOMINAL SIZE	 mm.	 PCS / BOX	 M2 / BOX	 BOX / PLT	 M2 / PLT	 KG. / PLT
60x60	10	3	1,08	40	43,20	960
45x45	9	7	1,42	26	36,9	709
33,3x33,3	8	14	1,55	44	68,2	1100

marble effect

effetto marmo
imitation marbre
Marmor-Optik
Мрамор

**cave
tile+**
pag. 172



cave
pag. 190



cave roc
pag. 196



cremo
pag. 198





COLORI

colours - couleurs - farbe - ЦВЕТА

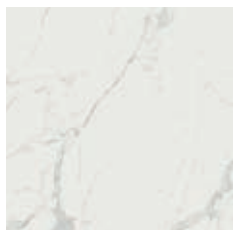

pietrasanta

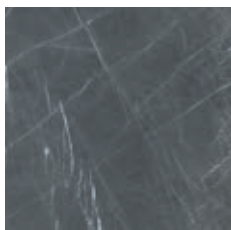

grafite

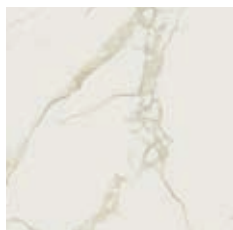

forte

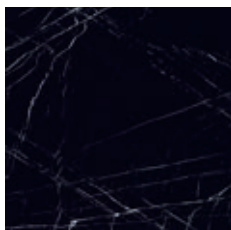

markina



lasa

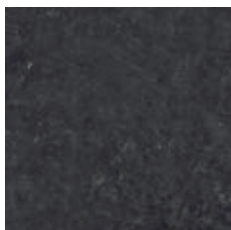

pierre blue

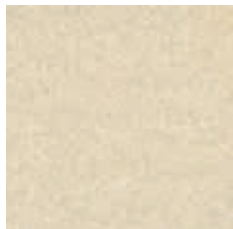

botticino



bronze

FORMATI

sizes - formats - format - ФОРМАТЫ



ONLY: pietrasanta / forte / lasa / grafite

160x320 (63"x126") NON RETTIFICATO

≠12

160x320 (63"x126") RETTIFICATO

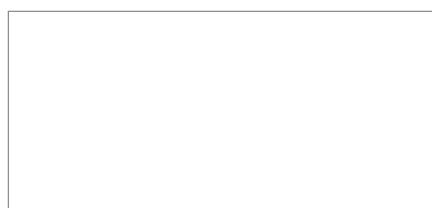

117,5x258,5 (46"x102") RETTIFICATO

≠6,5



117,5x235 (46"x92") RETTIFICATO

≠6,5



≠10
≠6,5

117,5x117,5 (46"x46") RETTIFICATO



≠6,5

59x117,5 (23"x46") RETTIFICATO

SUPERFICI

SURFACE

SURFACE

OBERFLACHE

ПОВЕРХНОСТИ

Matt

Matt

Matt

Matt

Натуральный

Lucido

Polished

Lucido

Lucido

Полированная



FUGA 2 mm

pietrasanta

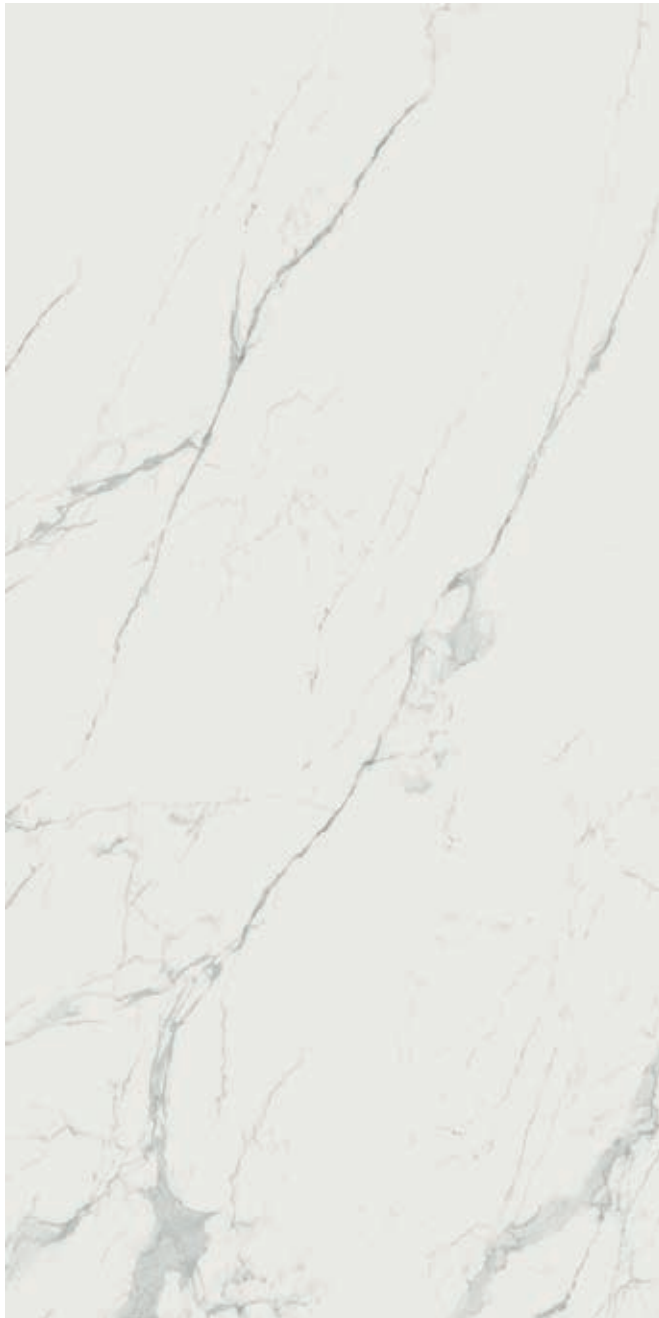

cave+TILE | marble effect



≠12

* 160x320 (63"x126")

T616125 matt rett.	131 ●
T616095 lucido rett.	139 ●
T616235 matt N/rett	127 ●
T616065 lucido N/rett	137 ●



≠6,5

117,5x258,5 (46"x102")

T600085 matt rett.	118 ●
T600265 lucido rett.	127 ●



≠6,5

117,5x235 (46"x92")

T610065 matt rett.	118 ●
T610125 lucido rett.	127 ●



117,5x117,5 (46"x46")

≠6,5	
T610185 matt rett.	108 ●
T610245 lucido rett.	119 ●



≠6,5

59x117,5 (23"x46")

T610305 matt rett.	108 ●
T610365 lucido rett.	119 ●

≠10	
T612045 matt rett.	108 ●
T612055 lucido rett.	119 ●

* Su richiesta possono essere forniti stuoiati.
On demand these products are available also with fiber glass backing.

pietrasanta running vein (vena continua)

4+4 lastre/slabs matt/lucido ≠6,5mm
117,5x258,5 (46"x102") - 117,5x235 (46"x92")

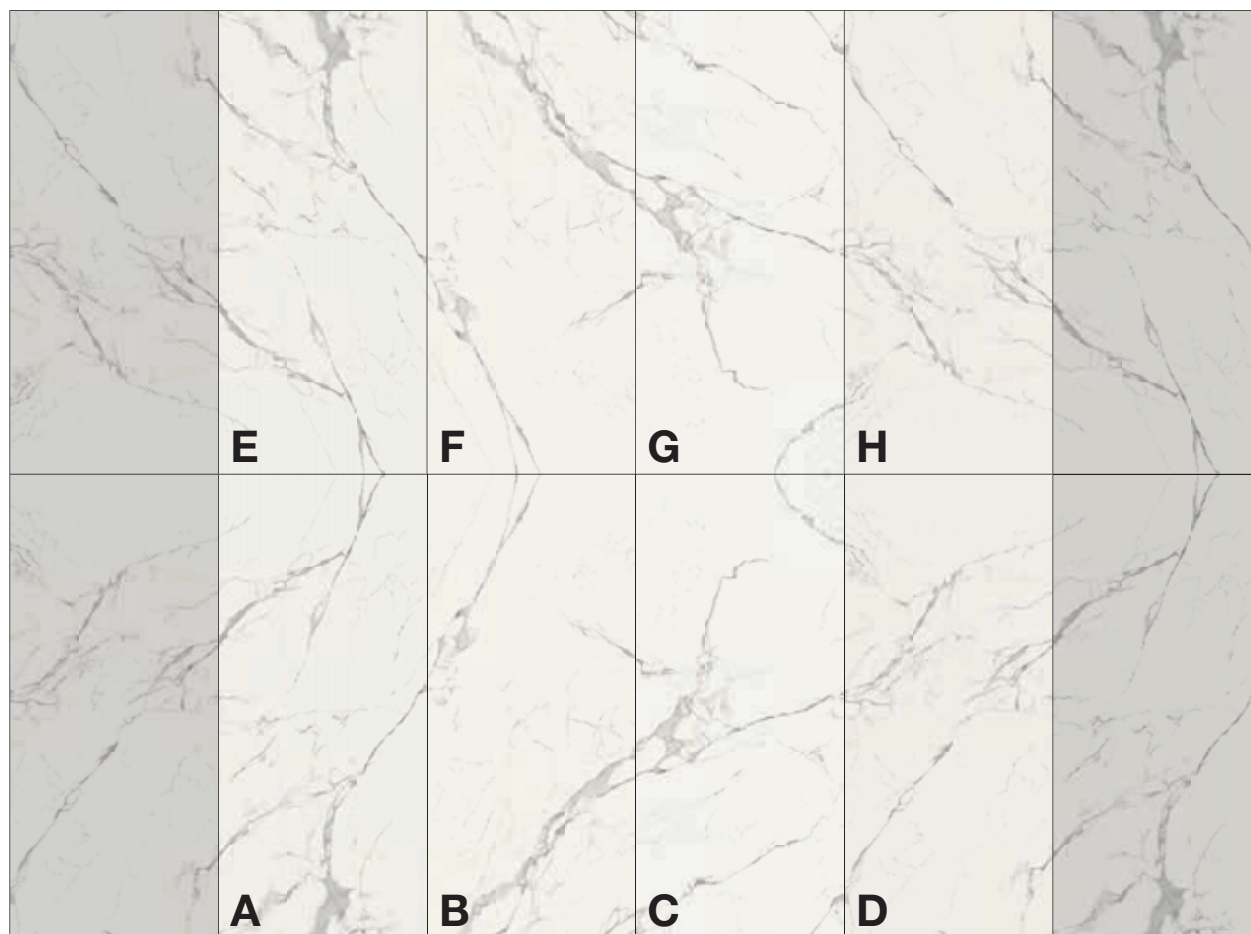

117,5x258,5 (46"x102")

matt rett. 130 ●

T600865 matt A
T600875 matt B
T600885 matt C
T600895 matt D
T600905 matt E
T600915 matt F
T600925 matt G
T600935 matt H

lucido rett. 137 ●

T600635 luc. A
T600655 luc. B
T600675 luc. C
T600695 luc. D
T600715 luc. E
T600735 luc. F
T600755 luc. G
T600775 luc. H

117,5x235 (46"x92")

matt rett. 130 ●

T611825 matt A
T611835 matt B
T611845 matt C
T611855 matt D
T611865 matt E
T611875 matt F
T611885 matt G
T611895 matt H

lucido rett. 137 ●

T611665 luc. A
T611675 luc. B
T611685 luc. C
T611695 luc. D
T611745 luc. E
T611755 luc. F
T611765 luc. G
T611775 luc. H

pietrasanta

2 lastre/slabs matt/lucido ≠6,5mm

117,5x258,5 (46"x102") - 117,5x235 (46"x92")

bookmatch

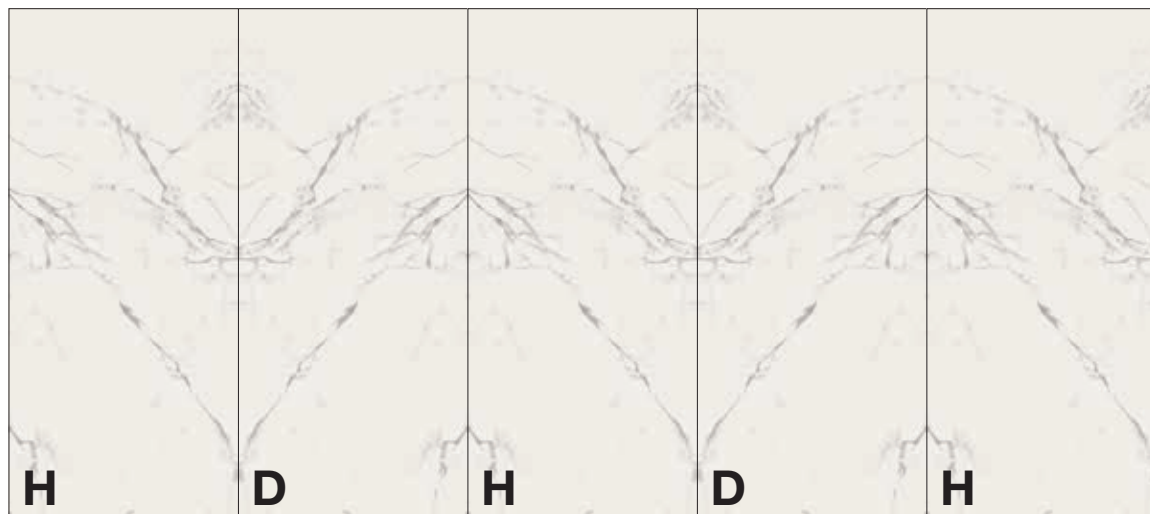

goldmatch

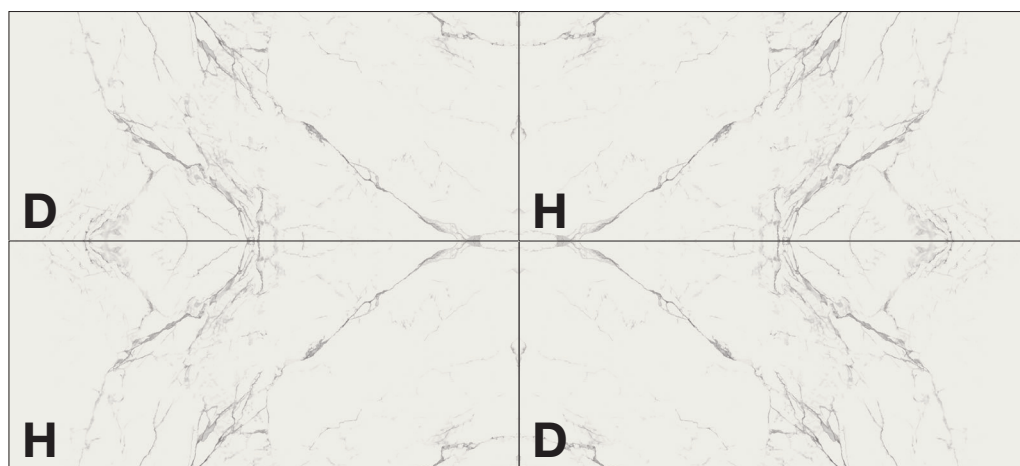

goldmatch

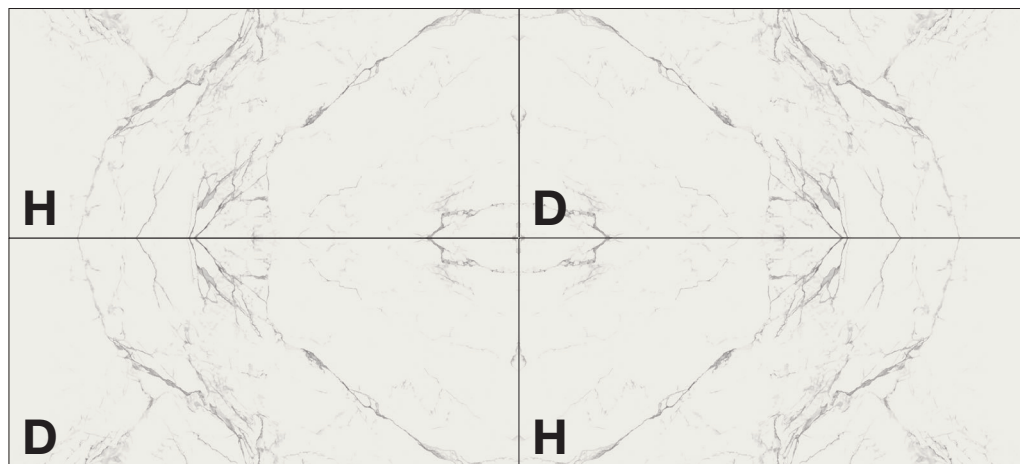

cave+TILE+ marble effect

bookmatch

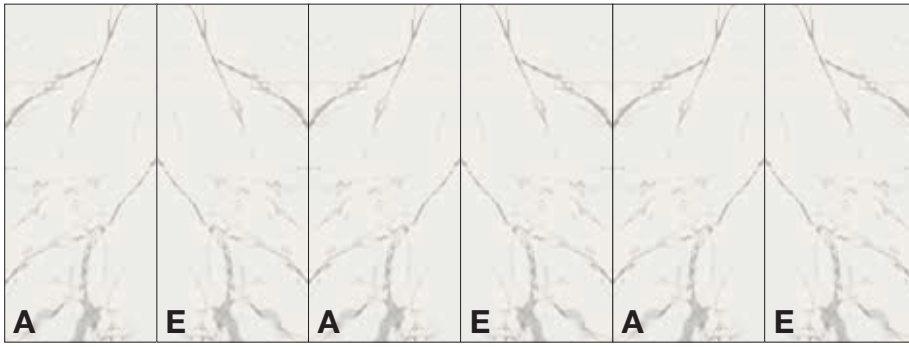

goldmatch

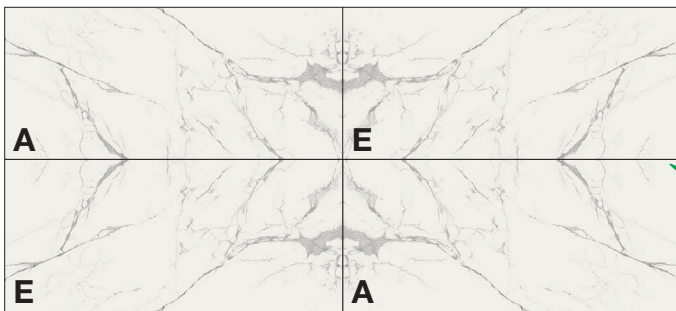

goldmatch

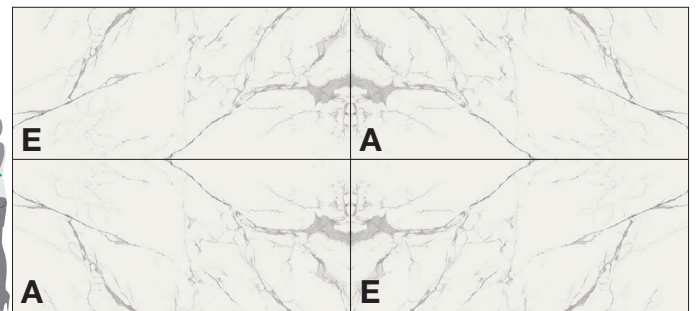

bookmatch



goldmatch

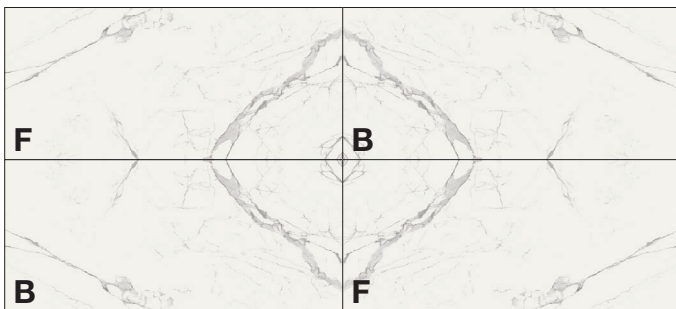

goldmatch

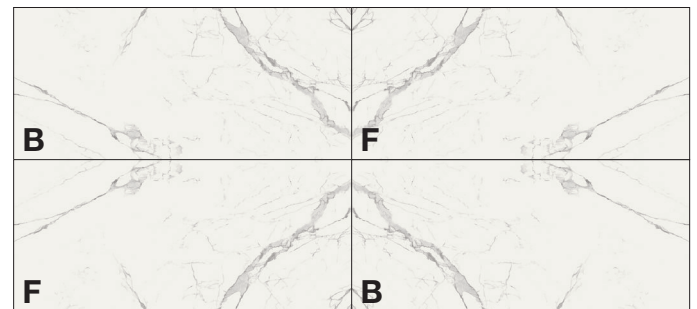

forte

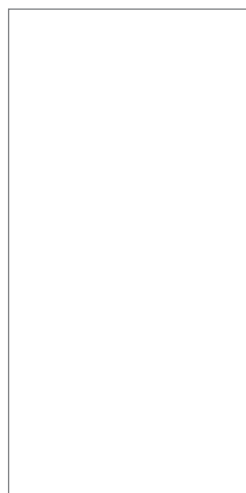

≠12

* 160x320 (63"x126")

T616135 matt rett.	131 ●
T616105 lucido rett.	139 ●
T616225 matt N/rett	127 ●
T616075 lucido N/rett	137 ●



≠6,5

117,5x258,5 (46"x102")

T600115 matt rett.	118 ●
T600295 lucido rett.	127 ●

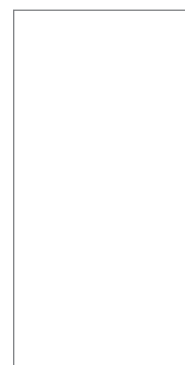

≠6,5

117,5x235 (46"x92")

T610095 matt rett.	118 ●
T610155 lucido rett.	127 ●



117,5x117,5 (46"x46")

≠6,5	
T610215 matt rett.	108 ●
T610275 lucido rett.	119 ●



≠6,5

59x117,5 (23"x46")

T610335 matt rett.	108 ●
T610395 lucido rett.	119 ●

≠10	
T612205 matt rett.	108 ●
T612215 lucido rett.	119 ●

* Su richiesta possono essere forniti stuoiati.
On demand these products are available also with fiber glass backing.

forte running vein (vena continua)

4+4 lastre/slabs matt/lucido ≠6,5mm

117,5x258,5 (46"x102") - 117,5x235 (46"x92")

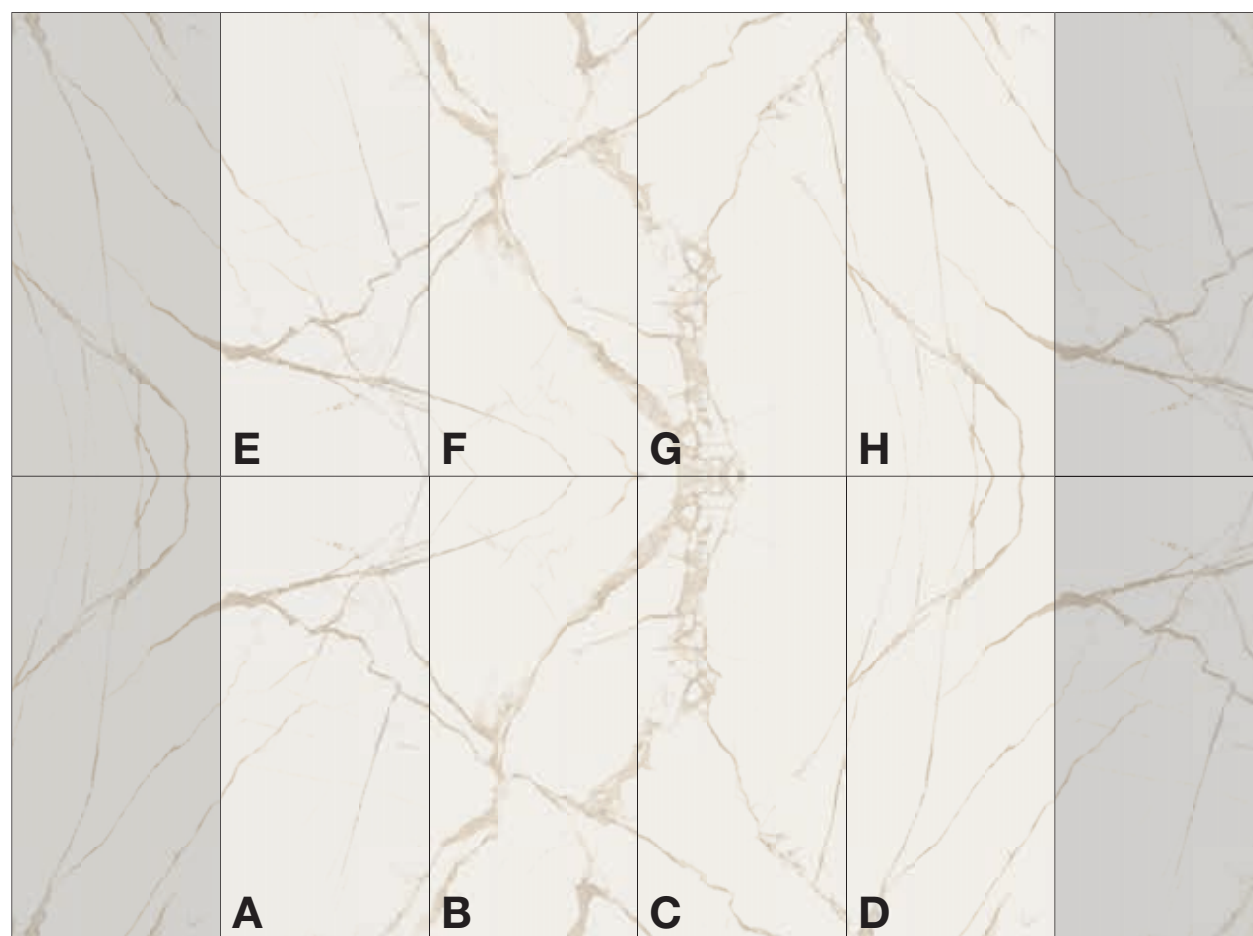

cave+ TILE+ | marble effect

117,5x258,5 (46"x102")

matt rett. 130 ●

T600785 matt A
T600795 matt B
T600805 matt C
T600815 matt D
T600825 matt E
T600835 matt F
T600845 matt G
T600855 matt H

lucido rett. 137 ●

T601045 luc. A
T601055 luc. B
T601065 luc. C
T601075 luc. D
T601085 luc. E
T601095 luc. F
T601105 luc. G
T601115 luc. H

117,5x235 (46"x92")

matt rett. 130 ●

T611905 matt A
T611915 matt B
T611925 matt C
T611935 matt D
T611945 matt E
T611955 matt F
T611965 matt G
T611975 matt H

lucido rett. 137 ●

T611705 luc. A
T611715 luc. B
T611725 luc. C
T611735 luc. D
T611785 luc. E
T611795 luc. F
T611805 luc. G
T611815 luc. H

forte

2 lastre/slabs matt/lucido ≠6,5mm

117,5x258,5 (46"x102") - 117,5x235 (46"x92")

bookmatch



goldmatch

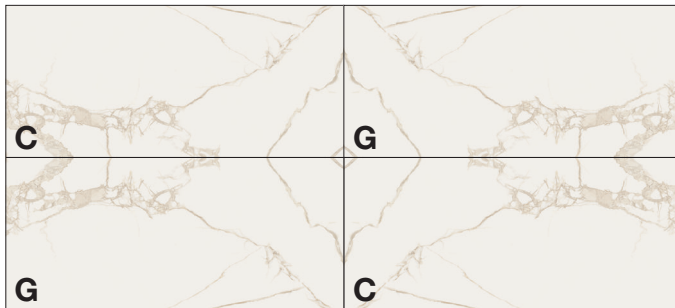

goldmatch

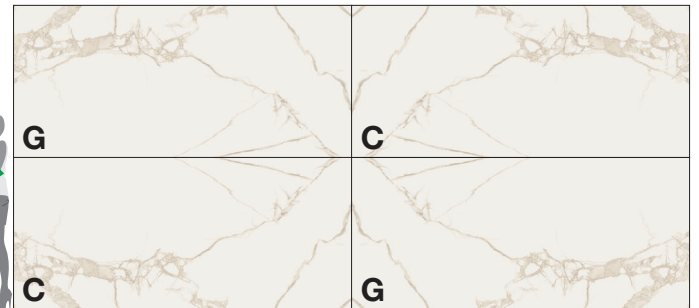

bookmatch



goldmatch

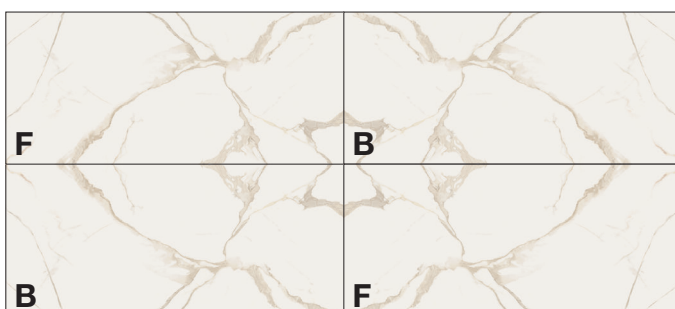

goldmatch



bookmatch



goldmatch

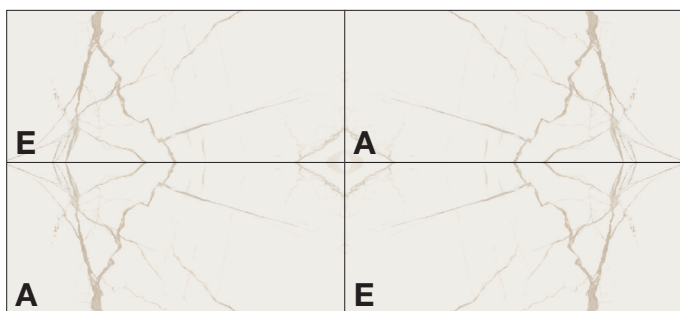

goldmatch

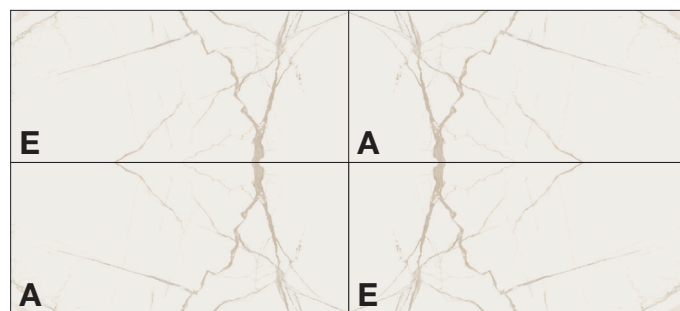

bookmatch

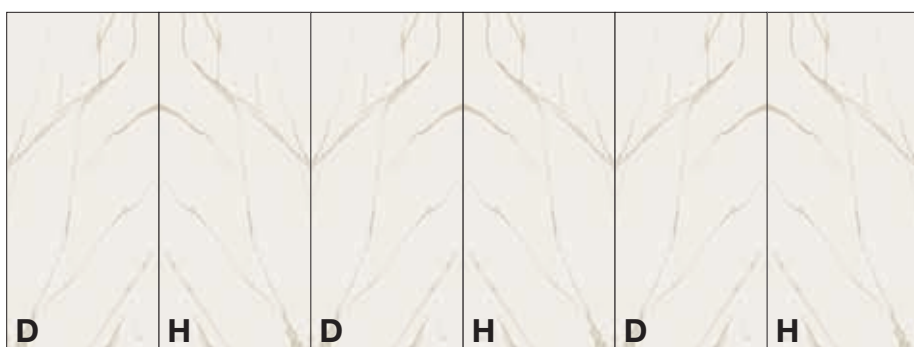

goldmatch

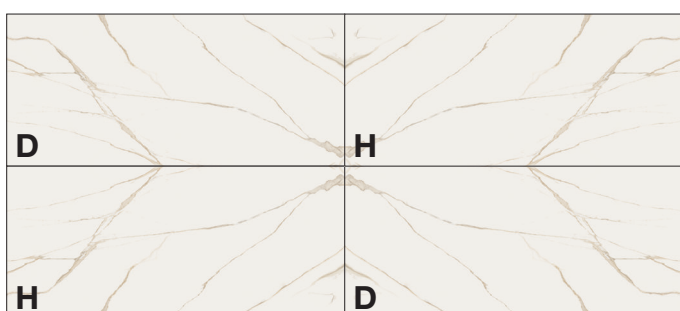

goldmatch

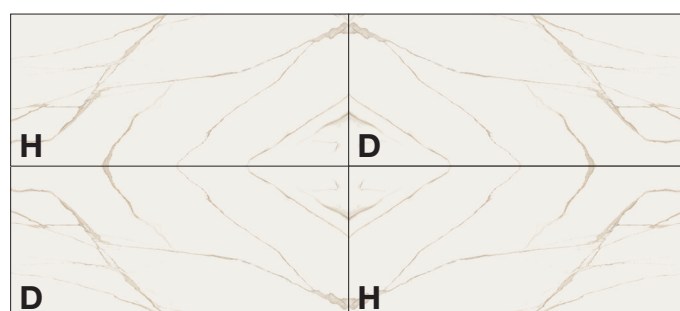

lasa



≠12

* 160x320 (63"x126")

T616265 lucido rett. 139 ●

T616275 lucido N/rett 137 ●

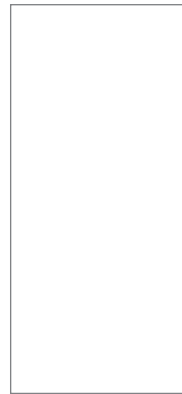

≠6,5

117,5x258,5 (46"x102")

T601035 lucido rett. 127 ●



≠6,5

117,5x235 (46"x92")

T613185 lucido rett. 127 ●



≠6,5

117,5x117,5 (46"x46")

T613175 lucido rett. 119 ●



≠6,5

59x117,5 (23"x46")

T613195 lucido rett. 119 ●

* Su richiesta possono essere forniti stuoiati.

On demand these products are available also with fiber glass backing.

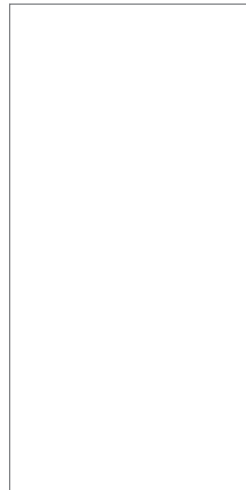

≠12

* 160x320 (63"x126")

T616145 matt rett.	131 ●
T616115 lucido rett.	139 ●
T616245 matt N/rett	127 ●
T616085 lucido N/rett	137 ●



≠6,5

117,5x258,5 (46"x102")

T600095 matt rett.	118 ●
T600275 lucido rett.	127 ●



≠6,5

117,5x235 (46"x92")

T610075 matt rett.	118 ●
T610135 lucido rett.	127 ●



117,5x117,5 (46"x46")

≠6,5	
T610195 matt rett.	108 ●
T610255 lucido rett.	119 ●



≠6,5

59x117,5 (23"x46")

T610315 matt rett.	108 ●
T610375 lucido rett.	119 ●

≠10

T612065 matt rett.	108 ●
T612075 lucido rett.	119 ●

* Su richiesta possono essere forniti stuoiati.
On demand these products are available also with fiber glass backing.

markina

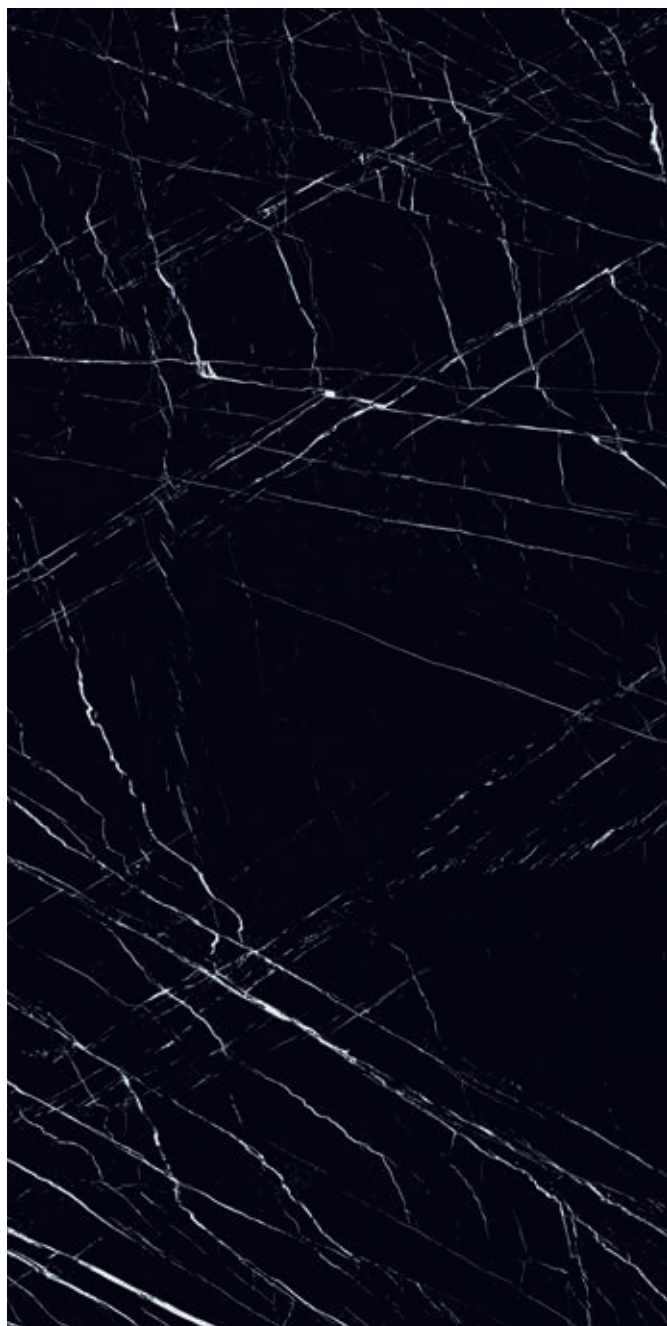

cave+TILE_{markina} | marble effect



117,5x258,5 (46"x102")
T601155 lucido rett. 127 ●



117,5x235 (46"x92")
T613255 lucido rett. 127 ●



117,5x117,5 (46"x46")
T613265 lucido rett. 119 ●



59x117,5 (23"x46")
T613275 lucido rett. 119 ●

pierre blue



117,5x258,5 (46"x102")
T600135 matt rett. 118 ●
T600315 lucido rett. 127 ●



117,5x235 (46"x92")
T610115 matt rett. 118 ●
T610175 lucido rett. 127 ●



117,5x117,5 (46"x46")
T610235 matt rett. 108 ●
T610295 lucido rett. 119 ●



59x117,5 (23"x46")
T610355 matt rett. 108 ●
T610415 lucido rett. 119 ●

botticino



cave+TILE | marble effect



117,5x258,5 (46"x102")
T600285 lucido rett. 127 ●



117,5x235 (46"x92")
T610145 lucido rett. 127 ●



117,5x117,5 (46"x46")
T610265 lucido rett. 119 ●



59x117,5 (23"x46")
T610385 lucido rett. 119 ●

bronze



117,5x258,5 (46"x102")
T600305 lucido rett. 127 ●



117,5x235 (46"x92")
T610165 lucido rett. 127 ●





117,5x117,5 (46"x46")
T610285 lucido rett. 119 ●



59x117,5 (23"x46")
T610405 lucido rett. 119 ●

IMBALLI packing - emballages - verpackung - УПАКОВКА

F.TO NOMINALE / NOMINAL SIZE	mm.	TIPOLOGIA IMBALLO / PACKAGING		LASTRA / SLAB			CASSA - CAVALLETTO / CRATE - A-FRAME			
		ARTICOLO / ITEM	DIMENSIONE / SIZE	PCS	M2	KG	PCS	M2	KG VUOTO/EMPTY	KG TOT
160x320 rett. - N/rett.	12	1 cavalletto / A-frame 	75x330x194h	1	5,12	150	20	102,4	193	3193
	12	2 cassa / crate 	175x345x37h	1	5,12	150	9	46,08	163	1513
117,5x258,5 rett.	6,5	3 cassa / crate 	136x284x38h	1	3,04	48,4	20	60,8	95	1063
117,5x235 rett.	6,5		136x264x38h	1	2,76	44,6	20	55,2	90	982

TILE+ PREMIUM SLABS	F.TO NOMINALE / NOMINAL SIZE	mm.	TIPOLOGIA IMBALLO / PACKAGING						
			ARTICOLO / ITEM	DIMENSIONE / SIZE	PCS / BOX	M2 / BOX	BOX / PLT	M2 / PLT	KG. / PLT
	117,5x117,5 rett.	6,5	pallet con sponda	123x143	2	2,76	24	66,24	1070
	117,5x117,5 rett.	10	pallet con sponda	123x143	2	2,76	18	49,68	829
	59x117,5 rett.	6,5	pallet	95x122	3	2,08	36	74,88	1204,2

¹ I cavalletti vengono sempre addebitati al costo di € 250,00

A-frames are always charged at a cost of €250.00

Die Transportböcke werden zum Preis von € 250,00 berechnet.

Les chevalets sont toujours livrés à un coût de 250,00 €

За подставки всегда взимается плата в размере 250,00 €

² Nel caso di piccole forniture il materiale verrà consegnato in casse addebitate al costo di € 160,00

In the case of small orders the material will be shipped in crates charged at a cost of €160.00

Bei kleinen Lieferungen wird das Material in Kisten ausgeliefert, die zum Preis von € 160,00 berechnet werden.

En cas de petites fournitures, le matériel sera livré dans des caisses ayant un coût de 160,00 €

В случае маленьких поставок материал будет доставляться в ящиках стоимостью 160,00 €

³ Per casse complete con un unico articolo la cassa viene fornita gratuita. Per vendite inferiori alla cassa completa la cassa viene addebitata al costo di € 70,00

If a crate is complete and contains one single item the crate is supplied free of charge. If a crate is not complete the crate is charged at a cost of €70.00

Bei kompletten Kisten, die einen einzigen Artikel enthalten, wird die Kiste nicht berechnet. Bei Verkäufen nicht kompletter Kisten werden die Kisten zum Preis von € 70,00 berechnet.

Pour des caisses remplies avec un seul article, celles-ci seront fournies gratuitement. Pour des ventes qui ne remplissent pas la caisse, celle-ci est vendue à un prix de 70,00 €

Ящики, заполненные полностью одним артикулом, поставляются бесплатно. При продаже количества меньше одного полного ящика взимается плата в размере 70,00 € за ящик

cave | marble effect



COLORI

colours - couleurs - farbe - ЦВЕТА

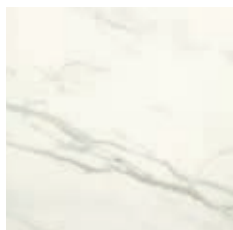

pietrasanta

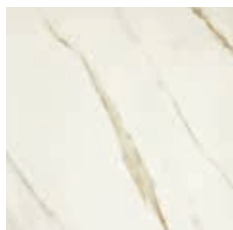

forte



lasa

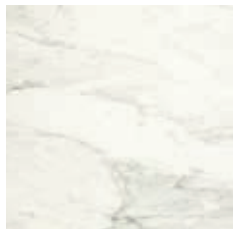

viareggio

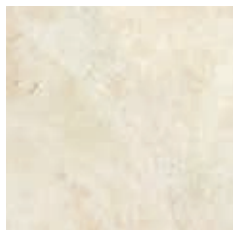

camaiole

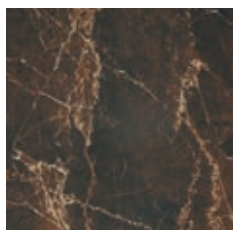

castellon

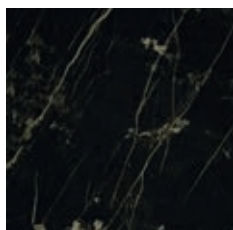

portovenere

FORMATI

sizes - formats - format - ФОРМАТЫ

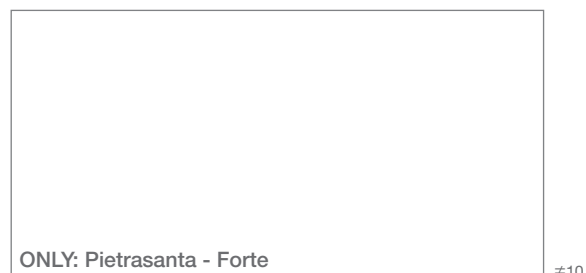

88x176 (34,6"x69,2") RETTIFICATO



59x117,5 (23"x46") RETTIFICATO



29,5x117,5 (11,5"x46") RETTIFICATO



88x88 (34,6"x34,6") RETTIFICATO

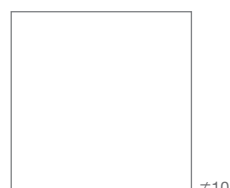

59x59 (23"x23") RETTIFICATO



29,5x59 (11,5"x23") RETTIFICATO



9,8x29,5 (3,8"x11,5") RETTIFICATO

a richiesta / on demand / sur demand / auf anfrage

> pag. 196

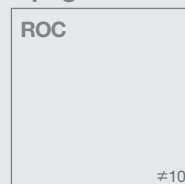

59x59 (23"x23") RETT.

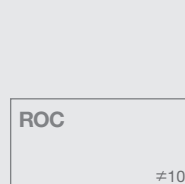

29,5x59 (11,5"x23") RETT.

SUPERFICI
SURFACE
SURFACE
OBERFLACHE
ПОВЕРХНОСТИ

Naturale
Natural
Naturelle
Matt
Натуральный

Lucido
Polished
Lucido
Lucido
Полированная



PIETRASANTA
LASA
VIAREGGIO
CASTELLON
CAMAIORE



FORTE
PORTOVENERE



POSA 1/4



FUGA 2 mm
PER RETTIFICATO

pietrasanta

forte

lasa



cave | marble effect

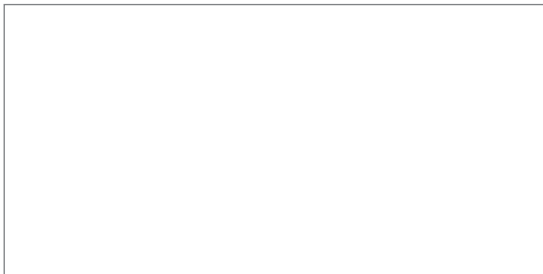

88x176 (34,6"x69,2")

naturale rett.

7680359 pietrasanta nat. rett.

7680349 forte nat. rett.

lucido rett.

7680399 pietrasanta luc. rett.

7680389 forte luc. rett.

111 ●

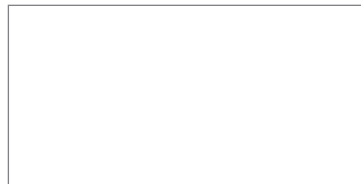

59x117,5 (23"x46")

naturale rett.

7681529 pietrasanta nat. rett.

7681539 forte nat. rett.

7648195 camaiore nat. rett.

7681549 viareggio nat. rett.

7651145 lasa nat. rett.

96 ●

lucido rett.

7681559 pietrasanta luc. rett.

7681569 forte luc. rett.

7648185 camaiore luc. rett.

7681579 viareggio luc. rett.

7651155 lasa luc. rett.

114 ●



29,5x117,5 (11,5"x46")

naturale rett.

7681949 pietrasanta nat. rett.

7681959 forte nat. rett.

7648215 camaiore nat. rett.

7682129 viareggio nat. rett.

7651165 lasa nat. rett.

96 ●

lucido rett.

7682169 pietrasanta luc. rett.

7682179 forte luc. rett.

7648205 camaiore luc. rett.

7682189 viareggio luc. rett.

7651175 lasa luc. rett.

114 ●

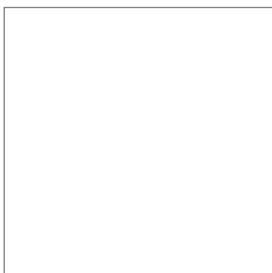

88x88 (34,6"x34,6")

naturale rett.

106 ●

7680429 pietrasanta nat. rett.

7680419 forte nat. rett.

lucido rett.

116 ●

7680449 pietrasanta luc. rett.

7680439 forte luc. rett.

viareggio



camaiore



mosaico 5x5 (2"x2") nat. 124 ● cave
 luc. 129 ●



30x30 (12"x12")
 7688105 forte nat.
 7688135 forte luc.

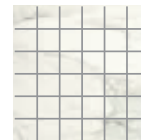

30x30 (12"x12")
 7688125 viareggio nat.
 7688155 viareggio luc.



30x30 (12"x12")
 7688115 pietrasanta nat.
 7688145 pietrasanta luc.



30x30 (12"x12")
 7690765 camaiore nat.
 7690755 camaiore luc.

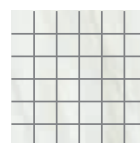

30x30 (12"x12")
 7694465 lasa nat.
 7694455 lasa luc.

mosaico intreccio 137 ●



30x30 (12"x12")
 7688065 forte lucido



30x30 (12"x12")
 7688055 pietrasanta lucido

mosaico class 2,3x2,3 (0,9"x0,9") 147 ●



30x30 (12"x12")
 7688085 forte lucido
 con tozzetti vetro oro



30x30 (12"x12")
 7688075 pietrasanta lucido
 con tozzetti vetro argento



59x59 (23"x23")
 naturale rett. 84 ●
 7687395 pietrasanta nat. rett.
 7687405 forte nat. rett.
 7690745 camaiore nat. rett.
 7687485 viareggio nat. rett.
 7694435 lasa nat. rett.

lucido rett. 102 ●
 7687415 pietrasanta luc. rett.
 7687425 forte luc. rett.
 7690735 camaiore luc. rett.
 7687495 viareggio luc. rett.
 7694445 lasa luc. rett.



29,5x59 (11,5"x23")
 naturale rett. 84 ●
 7687435 pietrasanta nat. rett.
 7687445 forte nat. rett.
 7690795 camaiore nat. rett.
 7687505 viareggio nat. rett.
 7651185 lasa nat. rett.

lucido rett. 102 ●
 7687455 pietrasanta luc. rett.
 7687465 forte luc. rett.
 7690785 camaiore luc. rett.
 7687515 viareggio luc. rett.
 7653015 lasa luc. rett.

london in marmo vero - real marble 81 ▲



4x29,5 (1,6"x11,5")
 7688089 marmo bianco sivec london

matita in marmo vero - real marble 55 ▲



2x29,5 (0,2"x11,5")
 7688099 marmo bianco sivec matita

portovenere

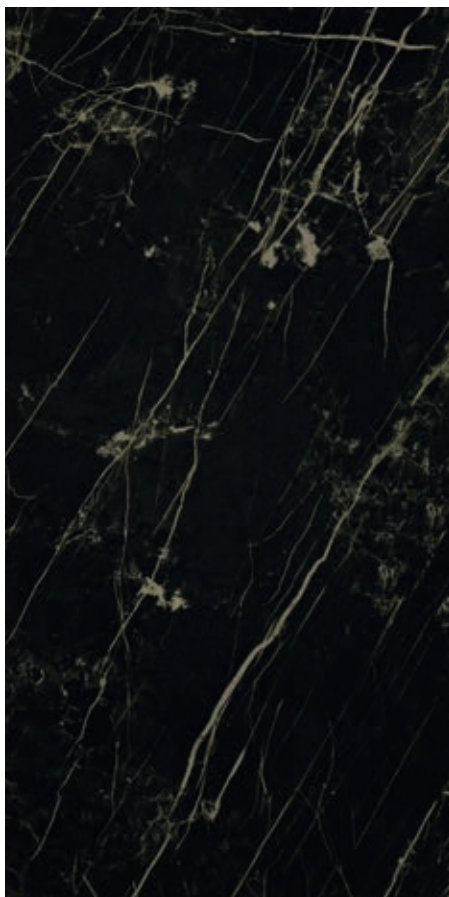

castellon

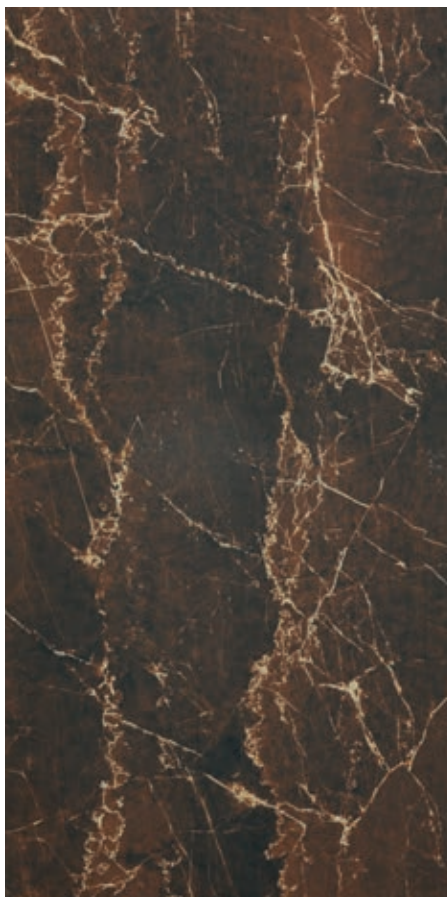

mosaico 5x5 (2"x2") nat. 124 ●
 luc. 129 ●

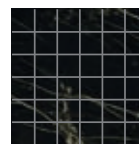

30x30 (12"x12")
 7690625 portovenere nat.
 7690645 portovenere luc.

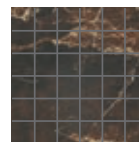

30x30 (12"x12")
 7690635 castellon nat.
 7690655 castellon luc.

mosaico intreccio 137 ●



30x30 (12"x12")
 7688066 portovenere lucido

cave | marble effect

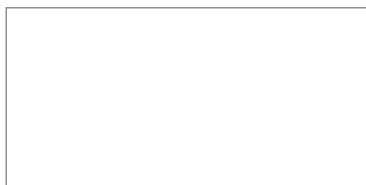

59x117,5 (23"x46")
naturale rett. 96 ●
 7681879 portovenere nat. rett.
 7681889 castellon nat. rett.

lucido rett. 114 ●
 7681899 portovenere luc. rett.
 7681909 castellon luc. rett.



59x59 (23"x23")
naturale rett. 84 ●
 7688515 portovenere nat. rett.
 7688525 castellon nat. rett.

lucido rett. 102 ●
 7688535 portovenere luc. rett.
 7688545 castellon luc. rett.



29,5x59 (11,5"x23")
naturale rett. 84 ●
 7688555 portovenere nat. rett.
 7688565 castellon nat. rett.

lucido rett. 102 ●
 7688575 portovenere luc. rett.
 7688585 castellon luc. rett.



29,5x117,5 (11,5"x46")
naturale rett. 96 ●
 7682139 portovenere nat. rett.
 7682149 castellon nat. rett.

lucido rett. 114 ●
 7682199 portovenere luc. rett.
 7682219 castellon luc. rett.



battiscopa naturale rett.

7x59 (3"x23")

- 7688015 forte naturale rett.
- 7688025 pietrasanta naturale rett.
- 7690746 camaiore naturale rett.
- 7688035 viareggio naturale rett.
- 7688095 castellon naturale rett.
- 7688586 portovenere naturale rett.
- 7651186 lasa naturale rett.

24 ▲ 14 ◻



battiscopa lucido rett.

7x59 (3"x23")

- 7687985 forte lucido rett.
- 7687995 pietrasanta lucido rett.
- 7690736 camaiore lucido rett.
- 7688005 viareggio lucido rett.
- 7688096 castellon lucido rett.
- 7688587 portovenere lucido rett.
- 7653016 lasa lucido rett.

28 ▲ 14 ◻

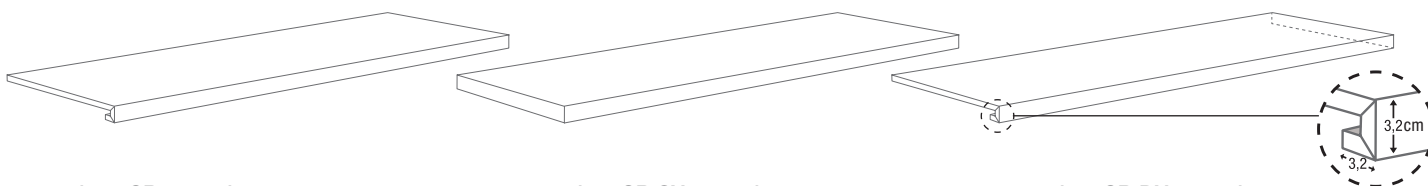

*** gradone CR naturale rett.**

33,3x117,5 (13"x46")

- 7688165 forte naturale rett.
- 7688175 pietrasanta naturale rett.
- 7648196 camaiore naturale rett.
- 7688185 viareggio naturale rett.
- 7688588 castellon naturale rett.
- 7688594 portovenere naturale rett.
- 7651148 lasa naturale rett.

142 ▲ 2 ◻

*** angolare CR SX naturale rett.**

33,3x117,5 (13"x46")

- 7688255 forte naturale rett.
- 7688265 pietrasanta naturale rett.
- 7648197 camaiore naturale rett.
- 7688275 viareggio naturale rett.
- 7688589 castellon naturale rett.
- 7688596 portovenere naturale rett.
- 7651147 lasa naturale rett.

147 ▲ 2 ◻

*** angolare CR DX naturale rett.**

33,3x117,5 (13"x46")

- 7688225 forte naturale rett.
- 7688235 pietrasanta naturale rett.
- 7648198 camaiore naturale rett.
- 7688245 viareggio naturale rett.
- 7688590 castellon naturale rett.
- 7688597 portovenere naturale rett.
- 7651146 lasa naturale rett.

147 ▲ 2 ◻

*** gradone CR lucido rett.**

33,3x117,5 (13"x46")

- 7688195 forte lucido rett.
- 7688205 pietrasanta lucido rett.
- 7648186 camaiore lucido rett.
- 7688215 viareggio lucido rett.
- 7688591 castellon lucido rett.
- 7688598 portovenere lucido rett.
- 7651158 lasa lucido rett.

146 ▲ 2 ◻

*** angolare CR SX lucido rett.**

33,3x117,5 (13"x46")

- 7688315 forte lucido rett.
- 7688325 pietrasanta lucido rett.
- 7648187 camaiore lucido rett.
- 7688335 viareggio lucido rett.
- 7688593 castellon lucido rett.
- 7688599 portovenere lucido rett.
- 7651157 lasa lucido rett.

149 ▲ 2 ◻

*** angolare CR DX lucido rett.**

33,3x117,5 (13"x46")

- 7688285 forte lucido rett.
- 7688295 pietrasanta lucido rett.
- 7648189 camaiore lucido rett.
- 7688305 viareggio lucido rett.
- 7688592 castellon lucido rett.
- 7688600 portovenere lucido rett.
- 7651156 lasa lucido rett.

149 ▲ 2 ◻

IMBALLI packing - emballages - verpackung - УПАКОВКА

F.TO NOMINALE / NOMINAL SIZE	mm.	PCS / BOX	M2 / BOX	BOX / PLT	M2 / PLT	KG. / PLT
88x176 rett.	10	1	1,55	30	46,50	1215
88x88 rett.	10	2	1,55	24	37,20	972
59x117,5 rett.	10	2	1,39	36	50,04	1152
29,5x117,5 rett.	10	3	1,04	20	20,80	480
59x59 rett.	10	3	1,044	40	41,76	960
29,5x59 rett.	10	7	1,22	36	43,92	900
30x30 mosaico 5x5	10	11	1,00	-	-	-
30x30 mosaico class	10	11	1,00	-	-	-
32x32 mosaico intreccio	10	11	1,126	-	-	-



pietrasanta roc



forte roc



portovenere roc

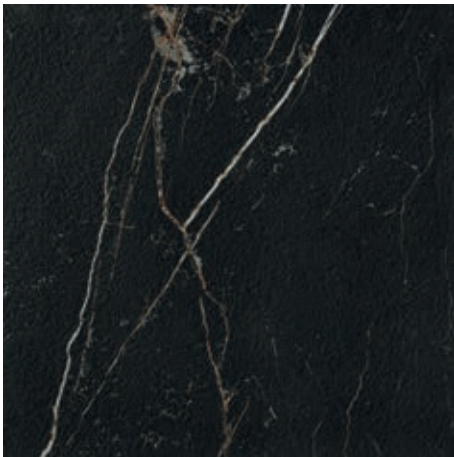

PEZZI SPECIALI

trims
pieces speciales
formstücke
СОБЫЕЭЛЕМЕНТЫ

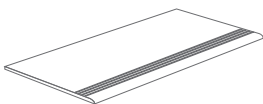

gradino step rettificato
29,5x59 (11,5"x23")
7691926 pietrasanta roc rett.
7691936 forte roc rett.
7691946 portovenere roc rett.

48 ▲ 7 ☐

mosaico 5x5 (2"x2") 124 ●

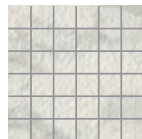

30x30 (12"x12")
7694215 pietrasanta roc



30x30 (12"x12")
7694225 forte roc

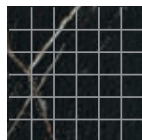

30x30 (12"x12")
7694235 portovenere roc



59x59 (23"x23")
rettificato 84 ●
7691895 pietrasanta roc rett.
7691905 forte roc rett.
7691915 portovenere roc rett.



29,5x59 (11,5"x23")
rettificato 84 ●
7691925 pietrasanta roc rett.
7691935 forte roc rett.
7691945 portovenere roc rett.

GM

V3



POSA 1/4



FUGA >3 mm



DIN 51130
R11



DIN 51097
A+B+C

IMBALLI packing - emballages - verpackung - УПАКОВКА

F.TO NOMINALE / NOMINAL SIZE	mm.	PCS / BOX	M2 / BOX	BOX / PLT	M2 / PLT	KG. / PLT
59x59 rett.	10	3	1,044	40	41,76	960
29,7x59 rett.	10	7	1,22	36	43,92	900
30x30 mosaico	10	11	1	-	-	-



effetto marmo

beige



30x60 (12"x24")
naturale 68 ●
 7675461 beige nat.
 7675451 bianco nat.
 7675471 perla nat.
 7675481 grigio nat.
 7675491 nero nat.

brick 3x10 (1,2"x4") 129 ●

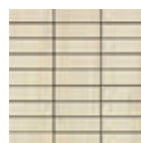

30x30 (12"x12")
 7677171 beige lapp.

bianco



29,7x59,5 (12"x24")
rettificato 78 ●
 7675631 beige rett.
 7675621 bianco rett.
 7675641 perla rett.
 7675651 grigio rett.
 7675661 nero rett.



30x30 (12"x12")
 7677181 bianco lapp.

perla



lappato rettificato 86 ●
 7675681 beige lapp. rett.
 7675671 bianco lapp. rett.
 7675691 perla lapp. rett.
 7675701 grigio lapp. rett.
 7675711 nero lapp. rett.



30x30 (12"x12")
 7677271 perla lapp.

grigio

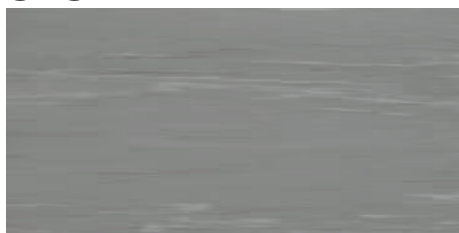

PEZZI SPECIALI
 trims
 pieces speciales
 formstücke
 СОБЫЕЭЛЕМЕНТЫ



30x30 (12"x12")
 7677191 grigio lapp.

nero

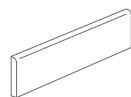

battiscopa lappato rett.
7,5x29,7 (3"x12")
 7677291 beige lapp. rett.
 7677301 bianco lapp. rett.
 7677311 grigio lapp. rett.
 7677321 nero lapp. rett.
 7677331 perla lapp. rett.



30x30 (12"x12")
 7677261 nero lapp.

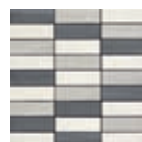

30x30 (12"x12")
 7677281 mix bi/pe/ne lapp.

SUPERFICI
 SURFACE
 SURFACE
 OBERFLACHE
 ПОВЕРХНОСТИ

Naturale
 Natural
 Naturelle
 Matt
 Натуральный

Lappato
 Semi-Polished
 Lappato
 Halbpoliert
 Полуполированный



POSA 1/4



FUGA 2 mm
 PER RETTIFICATO



FUGA >3 mm
 PER NATURALE

IMBALLI packing - emballages - verpackung - УПАКОВКА

F.TO NOMINALE / NOMINAL SIZE	mm.	PCS / BOX	M2 / BOX	BOX / PLT	M2 / PLT	KG. / PLT
30x60	9	7	1,26	40	50,4	989
29,7x59,5 rett.	9	7	1,24	40	49,6	973
30x30 brick	9	11	1,00	-	-	-

wood effect

effetto legno

imitation boi

Holzoptik

Дерево

alpi
pag. 202



majestic
pag. 208



natif light
pag. 210



painted
pag. 214





alpi | woda | rest

COLORI

colours - couleurs - farbe - ЦВѢТА



bianco

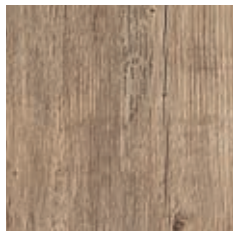

beige

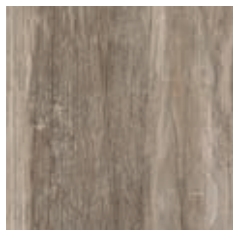

tortora

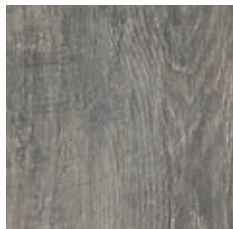

grigio

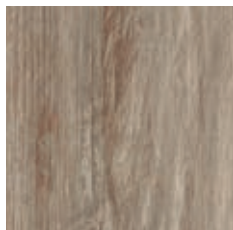

avana

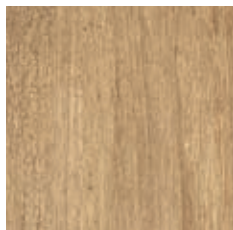

miele

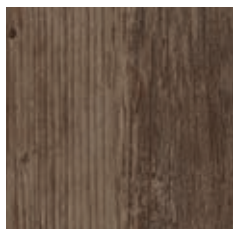

tabacco

FORMATI

sizes - formats - format - ФОРМАТЫ

naturale



25x151,2 (10"x60") RETTIFICATO

≠10

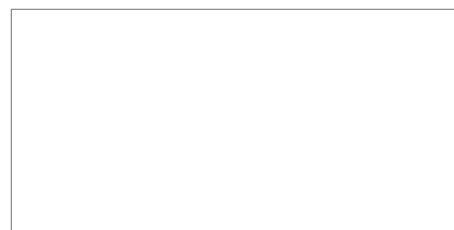

60x120 (24"x47") RETTIFICATO

≠10



30x120 (12"x47") RETTIFICATO

≠10



20x120 (8"x47") RETTIFICATO

≠10



15x90 (6"x36") NATURALE

≠8,5

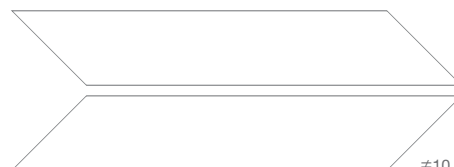

20x120 (8"x47") CHEVRON RETTIFICATO

≠10

grip



30x120 (12"x47") RETTIFICATO

≠10



20x120 (8"x47") RETTIFICATO

≠10



15x90 (6"x36") NATURALE

≠8,5

> pag. 228

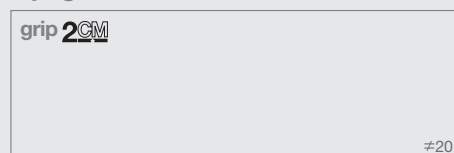

40x120 (16"x47") RETT.

≠20

SUPERFICI

SURFACE
SURFACE
OBERFLACHE
ПОВЕРХНОСТИ

Naturale

Natural
Naturelle
Matt
Натуральный

Grip

Grip
Grip
Grip
Grip
Grip



POSA 1/4



FUGA 2 mm



DIN 51130
R11 (GRIP)



DIN 51097
A+B+C (GRIP)

bianco



grigio



beige



tortora



naturale

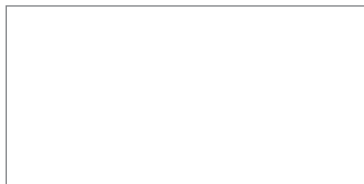

60x120 (24"x47")

rettificato

91 ●

7648485 bianco rett.
7648475 beige rett.
7648455 grigio rett.
7648465 tortora rett.
7649475 miele rett.
7649675 tabacco rett.
7649055 avana rett.



25x151,2 (10"x60")

rettificato

111 ●

7690419 bianco rett.
7690429 beige rett.
7690449 grigio rett.
7690439 tortora rett.
7690459 miele rett.
7690479 tabacco rett.



30x120 (12"x47")

rettificato

91 ●

7648575 bianco rett.
7648585 beige rett.
7648605 grigio rett.
7648595 tortora rett.
7649465 miele rett.
7649685 tabacco rett.
7649075 avana rett.

grip



30x120 (12"x47")

grip rettificato

91 ●

7649155 bianco grip rett.
7649145 beige grip rett.
7649125 grigio grip rett.
7649135 tortora grip rett.
7649645 miele grip rett.
7649705 tabacco grip rett.
7649165 avana grip rett.

miele



tabacco



avana



alpi

alpi | wood effect



20x120 (8"x47")

rettificato

93 ●

7648445 bianco rett.
7648435 beige rett.
7648415 grigio rett.
7648425 tortora rett.
7649455 miele rett.
7649695 tabacco rett.
7649065 avana rett.



15x90 (6"x36")

naturale

76 ●

7670149 bianco naturale
7670159 beige naturale
7670179 grigio naturale
7670169 tortora naturale
7670189 miele naturale
7670249 tabacco naturale

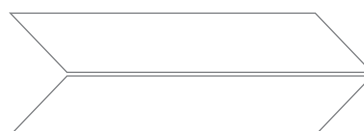

20x120 (8"x47")

rettificato

127 ●

7649415 bianco rett.
7649405 beige rett.
7649425 grigio rett.
7649435 tortora rett.
7649485 miele rett.
7649755 tabacco rett.
7649395 avana rett.

grip



20x120 (8"x47")

grip rettificato

93 ●

7648855 bianco grip rett.
7648865 beige grip rett.
7649115 grigio grip rett.
7648875 tortora grip rett.
7649635 miele grip rett.
7649715 tabacco grip rett.
7649105 avana grip rett.

grip

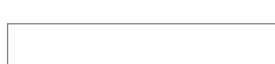

15x90 (6"x36")

grip

76 ●

7670199 bianco grip
7670209 beige grip
7670229 grigio grip
7670219 tortora grip
7670239 miele grip
7670259 tabacco grip

Composto da due facce DX e SX
Composed of left and right sides

PEZZI SPECIALI trims - pieces speciales - formstücke - СОБЫЕЭЛЕМЕНТЫ

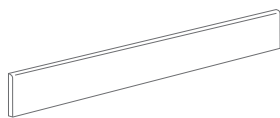

battiscopa

7,5x90 (3"x36")

- 7670150 bianco
- 7670160 beige
- 7670180 grigio
- 7670170 tortora
- 7670190 miele
- 7670250 tabacco

40 ▲ 5 📦

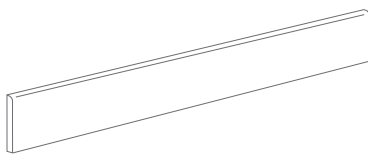

battiscopa rett.

10x120 (4"x47")

- 7648446 bianco rett.
- 7648436 beige rett.
- 7648416 grigio rett.
- 7648426 tortora rett.
- 7649056 avana rett.
- 7648456 miele rett.
- 7649676 tabacco rett.

48 ▲ 4 📦

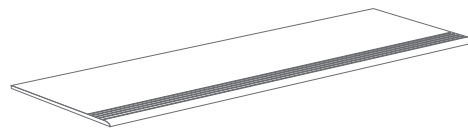

gradino step rett.

30x120 (12"x47")

- 7649062 bianco rett.
- 7649061 beige rett.
- 7649063 grigio rett.
- 7649069 tortora rett.
- 7649060 avana rett.
- 7649067 miele rett.
- 7649068 tabacco rett.

106 ▲ 4 📦

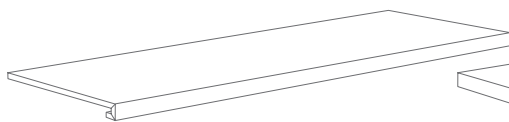

*** gradone CR naturale rett.**

33,3x120 (13"x47")

- 7648487 bianco rett.
- 7648477 beige rett.
- 7648459 grigio rett.
- 7648467 tortora rett.
- 7649057 avana rett.
- 7649477 miele rett.
- 7649677 tabacco rett.

142 ▲ 2 📦

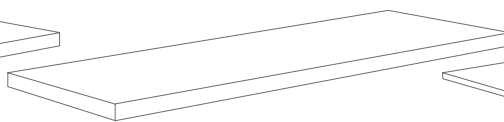

*** angolare CR SX naturale rett.**

33,3x120 (13"x47")

- 7648489 bianco rett.
- 7648480 beige rett.
- 7648461 grigio rett.
- 7648470 tortora rett.
- 7649059 avana rett.
- 7649480 miele rett.
- 7649679 tabacco rett.

147 ▲ 2 📦

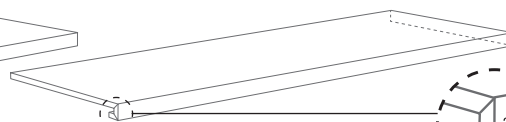

*** angolare CR DX naturale rett.**

33,3x120 (13"x47")

- 7648488 bianco rett.
- 7648479 beige rett.
- 7648460 grigio rett.
- 7648469 tortora rett.
- 7649058 avana rett.
- 7649479 miele rett.
- 7649678 tabacco rett.

147 ▲ 2 📦

alpi | wood effect

IMBALLI packing - emballages - verpackung - УПАКОВКА

F.TO NOMINALE / NOMINAL SIZE	mm.	PCS / BOX	M2 / BOX	BOX / PLT	M2 / PLT	KG. / PLT
25x151,2 rett.	10	3	1,134	48	54,432	1209,60
60x120 rett.	10	2	1,44	36	51,84	1152
30x120 rett.	10	3	1,08	20	21,60	480
20x120 rett.	10	4	0,96	32	30,72	688
15x90	8,5	7	0,945	48	45,36	884,5
20x120 chevron rett.	10	4	0,80	32	25,60	688



alpi | wood effect



natural



75,5x75,5 (30"x30")
7690189 rett.

87 ●

bruciato



75,5x75,5 (30"x30")
7690199 rett.

87 ●

GM

V3



FUGA 2 mm
PER RETTIFICATO

PEZZI SPECIALI trims - pieces speciales - formstücke - СОБЫЕЭЛЕМЕНТЫ

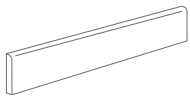

battiscopa rett.

11x75,5 (4,3"x30")

7690209 natural rett.

7690229 bruciato rett.

38 ▲ 4 📦

IMBALLI packing - emballages - verpackung - УПАКОВКА

F.TO NOMINALE / NOMINAL SIZE	mm.	PCS / BOX	M2 / BOX	BOX / PLT	M2 / PLT	KG. / PLT
75,5x75,5 rett.	10	2	1,14	45	51,30	1125



natif light | wood effect



COLORI

colours - couleurs - farbe - ЦВЕТА



ambra

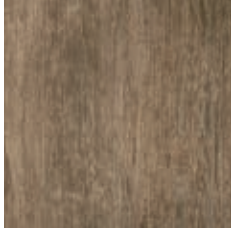

ginepro

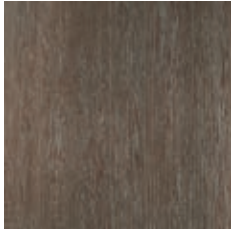

curry

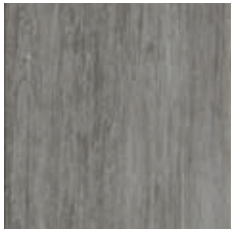

pepe

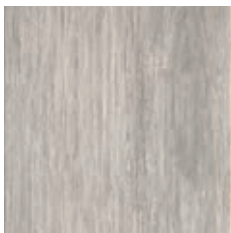

cumino

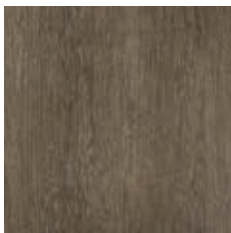

zenzero



vaniglia

FORMATI

sizes - formats - format - ФОРМАТЫ

naturale



≠9

30x60 (12"x24") NATURALE

29,7x59,5 (12"x24") RETTIFICATO



≠9

15x60 (6"x24") NATURALE

14,8x59,5 (6"x24") RETTIFICATO



≠9

9,8x59,5 (4"x24") RETTIFICATO

grip



≠9

30x60 (12"x24") NATURALE

29,7x59,5 (12"x24") RETTIFICATO



≠9

15x60 (6"x24") NATURALE

14,8x59,5 (6"x24") RETTIFICATO

SUPERFICI

SURFACE

SURFACE

OBERFLACHE

ПОВЕРХНОСТИ

Naturale

Natural

Naturelle

Matt

Натуральный

Grip

Grip

Grip

Grip

Grip

Grip

Grip



POSA 1/4



FUGA 2 mm
PER RETTIFICATO



FUGA >3 mm
PER NATURALE



DIN 51130
R11 (GRIP)



DIN 51097
B (GRIP)

ambra



pepe

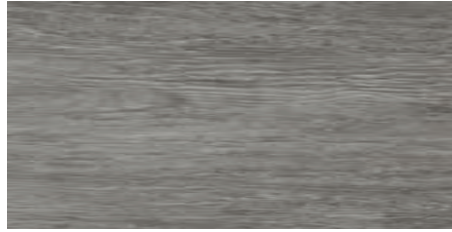

naturale



30x60 (12"x24")

naturale 68 ●

7664085 ambra nat.
7664135 ginepro nat.
7664125 curry nat.
7674771 pepe nat.
7674781 cumino nat.
7664095 zenzero nat.
7664105 vaniglia nat.

ginepro



cumino



29,7x59,5 (12"x24")

rettificato 78 ●

7664145 ambra rett.
7664195 ginepro rett.
7664185 curry rett.
7675075 pepe rett.
7675085 cumino rett.
7664155 zenzero rett.
7664165 vaniglia rett.

curry



vaniglia

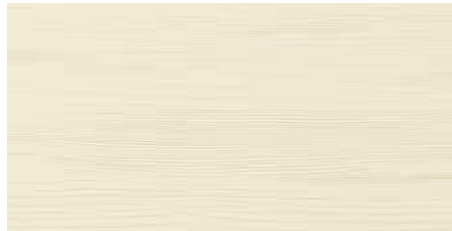

15x60 (6"x24")

naturale 68 ●

7700001 ambra nat.
7700051 ginepro nat.
7700041 curry nat.
7700061 pepe nat.
7700071 cumino nat.
7700021 zenzero nat.
7700031 vaniglia nat.

zenzero



14,8x59,5 (6"x24")

rettificato 87 ●

7664265 ambra rett.
7664315 ginepro rett.
7664305 curry rett.
7675035 pepe rett.
7675045 cumino rett.
7664275 zenzero rett.
7664285 vaniglia rett.



9,8x59,5 (4"x24")

rettificato 87 ●

7664205 ambra rett.
7664255 ginepro rett.
7664245 curry rett.
7675015 pepe rett.
7675025 cumino rett.
7664215 zenzero rett.
7664225 vaniglia rett.

grip



30x60 (12"x24")

grip 68 ●

7665235 ambra grip
7665225 ginepro grip
7665245 curry grip
7674791 pepe grip
7674801 cumino grip

29,7x59,5 (12"x24")

grip rettificato 78 ●

7665265 ambra grip rett.
7665255 ginepro grip rett.
7665275 curry grip rett.
7675135 pepe grip rett.
7675145 cumino grip rett.



15x60 (6"x24")

grip 68 ●

7700081 ambra grip
7700101 ginepro grip
7700091 curry grip
7700111 pepe grip
7700121 cumino grip
7700161 zenzero grip
7700181 vaniglia grip

14,8x59,5 (6"x24")

grip rettificato 87 ●

7669111 ambra grip rett.
7669121 ginepro grip rett.
7669131 curry grip rett.
7675115 pepe grip rett.
7675125 cumino grip rett.



9,8x59,5 (4"x24")

grip rettificato 87 ●

7667395 ambra grip rett.
7667415 ginepro grip rett.
7667405 curry grip rett.
7675095 pepe grip rett.
7675105 cumino grip rett.

PEZZI SPECIALI

trims - pieces speciales - formstücke - СОБИЕЭЛЕМЕНТЫ

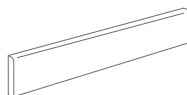

battiscopa naturale
7,5x60 (3"x24")

7666135 ambra naturale
7666145 ginepro naturale
7666469 zenzero naturale
7666155 curry naturale
7666459 vaniglia naturale
7675181 cumino naturale
7675171 pepe naturale

24 ▲ 14 ☐



battiscopa rett.
7,5x59,5 (3"x24")

7681139 ambra rett.
7681179 ginepro rett.
7681149 zenzero rett.
7681169 curry rett.
7681159 vaniglia rett.
7675161 cumino rett.
7675151 pepe rett.

24 ▲ 14 ☐

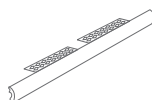

* **torello gradino rett.**
4x59,5 (1,5"x24")

7666169 ambra rett.
7666309 ginepro rett.
7666339 zenzero rett.
7666299 curry rett.
7666329 vaniglia rett.
7675209 cumino rett.
7675199 pepe rett.

99 ▲ 4 ☐

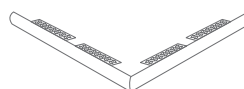

* **torello set angolare rett.**
4x59,5 (1,5"x24")

7666349 ambra rett.
7666369 ginepro rett.
7666399 zenzero rett.
7666359 curry rett.
7666389 vaniglia rett.
7675229 cumino rett.
7675219 pepe rett.

126 ▲ 2 set ☐

IMBALLI packing - emballages - verpackung - УПАКОВКА

F.TO NOMINALE / NOMINAL SIZE	mm.	PCS / BOX	M2 / BOX	BOX / PLT	M2 / PLT	KG. / PLT
30x60	9	7	1,26	40	50,40	989
29,7x59,5 rett.	9	7	1,24	40	49,6	973
15x60	9	14	1,26	40	50,40	1040
19,8x59,5 rett.	9	10	1,18	48	56,64	1152
14,8x59,5 rett.	9	14	1,23	40	49,20	1000
9,8x59,5 rett.	9	20	1,17	40	46,80	900



COLORI

colours - couleurs - farbe - ЦВЕТА



white



beige

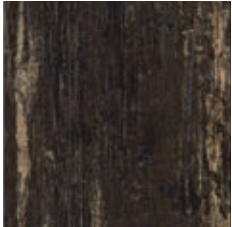

wengé



grey



dark

FORMATI

sizes - formats - format - ФОРМАТЫ

naturale



±8,5

15x90 (6"x36")

grip



±8,5

15x90 (6"x36")

SUPERFICI

SURFACE

SURFACE

OBERFLACHE

ПОВЕРХНОСТИ

Naturale

Natural

Naturelle

Matt

Натуральный

Grip

Grip

Grip

Grip

Grip

Grip



POSA 1/4



FUGA >3 mm



DIN 51130

R11 (GRIP)



DIN 51097

A+B+C (GRIP)

beige



wengé



grey



dark



white



15x90 (6"x36")

naturale

76 ●

- 7670019 white nat.
- 7670039 beige nat.
- 7670089 wengé nat.
- 7670029 grey nat.
- 7670009 dark nat.

grip

76 ●

- 7670008 white grip
- 7670119 beige grip
- 7670099 wengé grip
- 7670018 grey grip
- 7670028 dark grip



PEZZI SPECIALI trims - pieces speciales - formstücke - СОБЫЕЭЛЕМЕНТЫ

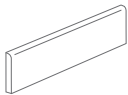

battiscopa

8x45 (3"x18")

- 7670020 white
- 7670129 beige
- 7670109 wengé
- 7670030 grey
- 7670010 dark

18 ▲ 12 ▢

IMBALLI packing - emballages - verpackung - УПАКОВКА

F.TO NOMINALE / NOMINAL SIZE	mm.	PCS / BOX	M2 / BOX	BOX / PLT	M2 / PLT	KG. / PLT
15x90	8,5	7	0,945	48	45,36	884,54

Painted



Painted | wood effect

5mm collection

**home5+
apuano**
pag. 220



**marble
effect**

**home5+
linfa**
pag. 222



**wood
effect**

**home5+
material**
pag. 224



**cement
effect**



home5+ | 5mm marble effect

marble effect

apiano bianco

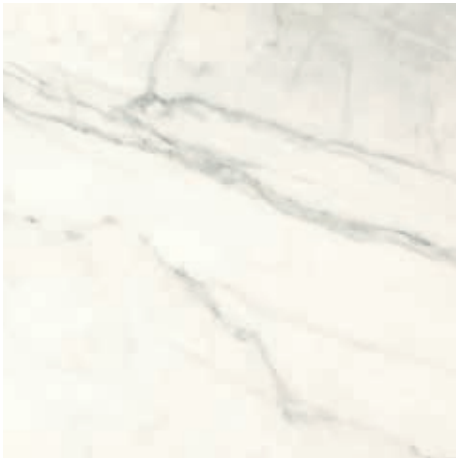

59,5x59,5 (24"x24")
T620245 nat. rett.

83 ●

GM

V2



POSA 1/4



FUGA 2 mm
PER RETTIFICATO

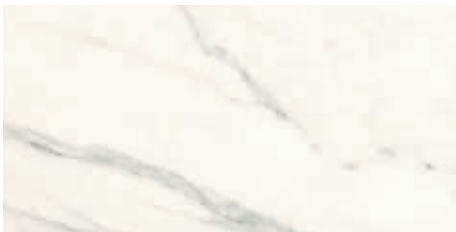

29,7x59,5 (12"x24")
T620235 nat. rett.

83 ●

PEZZI SPECIALI trims - pieces speciales - formstücke - СОБЫЕЭЛЕМЕНТЫ

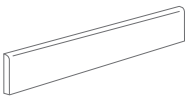

battiscopa nat. rett.
7,5x59,5 (3"x24")
T620236 apiano bianco nat. rett.

30 ▲ 24 ◻

IMBALLI packing - emballages - verpackung - УПАКОВКА

F.TO NOMINALE / NOMINAL SIZE	mm.	PCS / BOX	M2 / BOX	BOX / PLT	M2 / PLT	KG. / PLT
59,5x59,5 rett.	5	6	2,124	40	84,96	1000
29,7x59,5 rett.	5	12	2,120	40	84,80	1000



home5+ 5mm wood effect

wood effect

linfa bianco

linfa grigio

linfa beige



≠5

20x120 (12"x47")
T620165 rett.

93 ●



≠5

20x120 (12"x47")
T620175 rett.

93 ●



≠5

20x120 (12"x47")
T620185 rett.

93 ●

GM

V3



POSA 1/4



FUGA 2 mm
PER RETTIFICATO

PEZZI SPECIALI trims - pieces speciales - formstücke - СОБИЕЭЛЕМЕНТЫ

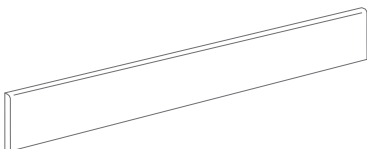

battiscopa rett.

10x120 (6"x47")

T620166 linfa bianco rett.

T620176 linfa grigio rett.

T620186 linfa beige rett.

52 ▲

6

IMBALLI packing - emballages - verpackung - УПАКОВКА

F.TO NOMINALE / NOMINAL SIZE	mm.	PCS / BOX	M2 / BOX	BOX / PLT	M2 / PLT	KG. / PLT
20x120 rett.	5	8	1,92	32	61,44	552

home5+ | 15mm cement effect



cement effect

material nero

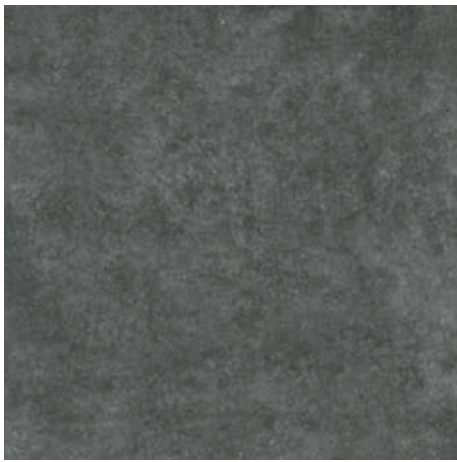

59,5x59,5 (24"x24")
T620215 rett.

83 ●

material grigio



59,5x59,5 (24"x24")
T620225 rett.

83 ●

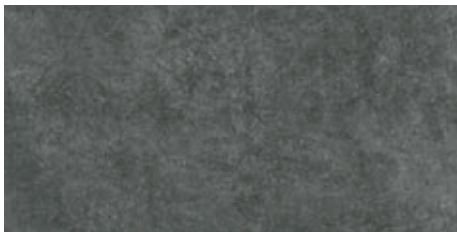

29,7x59,5 (12"x24")
T620195 rett.

83 ●



29,7x59,5 (12"x24")
T620205 rett.

83 ●



PEZZI SPECIALI trims - pieces speciales - formstücke - СОБИЕЭЛЕМЕНТЫ

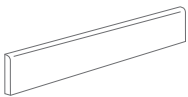

battiscopa rett.
7,5x59,5 (3"x24")

T620196 material nero rett.
T620206 material grigio rett.

30 ▲ 24 📦

IMBALLI packing - emballages - verpackung - УПАКОВКА

F.TO NOMINALE / NOMINAL SIZE	mm.	PCS / BOX	M2 / BOX	BOX / PLT	M2 / PLT	KG. / PLT
59,5x59,5 rett.	5	6	2,124	40	84,96	1000
29,7x59,5 rett.	5	12	2,120	40	84,80	1000

2CM

outdoor
paving 20mm

alpi grip
pag. 228



artica roc
pag. 230



neutra roc
pag. 232



urbandeck grip
pag. 234





alpi grip | 2CM

PAVIMENTI A SECCO PER ESTERNI
DRY-LAID FLOORING FOR OUTDOOR USE
DALLAGES A SEC POUR EXTERIEURS
TROCKENFUSSBÖDEN FÜR AUSSENÄRÄUME

avana grip



40x120 (16"x47")
7695029 rett.

110 ●

beige grip



40x120 (16"x47")
7695009 rett.

110 ●

miele grip



40x120 (16"x47")
7695019 rett.

110 ●

GM

V3



DIN 51130
R11



DIN 51097
A+B+C

PEZZI SPECIALI trims - pieces speciales - formstücke - СОБЫЕЭЛЕМЕНТЫ



elemento elle rett.

40x120x4 (16"x47"x1,5")

7695028 avana grip rett.

7695008 beige grip rett.

7695018 miele grip rett.

135 ▲ 2 ◻

IMBALLI packing - emballages - verpackung - УПАКОВКА

F.TO NOMINALE / NOMINAL SIZE	 mm.	 PCS / BOX	 M2 / BOX	 BOX / PLT	 M2 / PLT	 KG. / PLT
40x120 Rett.	20	2	0,96	32	30,72	1444



PAVIMENTI A SECCO PER ESTERNI
DRY-LAID FLOORING FOR OUTDOOR USE
DALLAGES A SEC POUR EXTERIEURS
TROCKENFUSSBÖDEN FÜR AUSSENÄRÄUME

bianco roc



60,5x60,5 (24"x24")
7690718 rett.

106 ●

≠20

nube roc

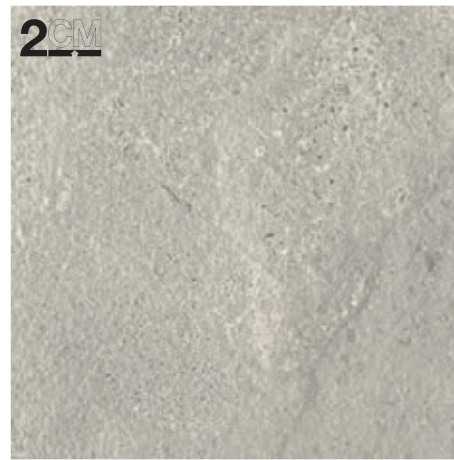

60,5x60,5 (24"x24")
7688478 rett.

106 ●

≠20

GM

V3



DIN 51130
R11



DIN 51097
A+B+C

brandy roc

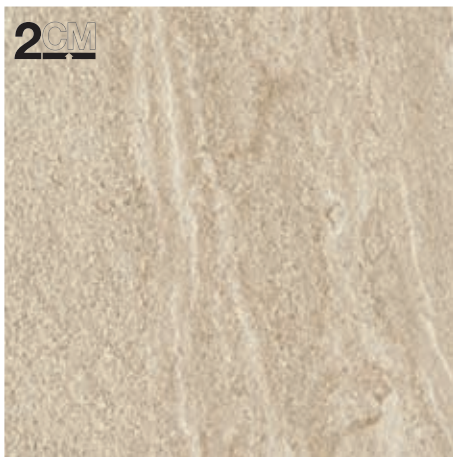

60,5x60,5 (24"x24")
7688468 rett.

106 ●

≠20

grigio roc

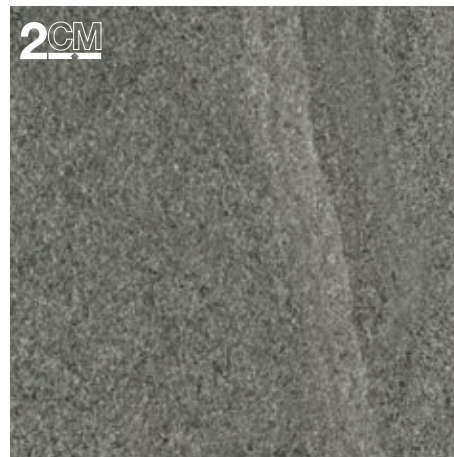

60,5x60,5 (24"x24")
7688488 rett.

106 ●

≠20

PEZZI SPECIALI

trims
pieces speciales
formstücke
СОБЫЕЭЛЕМЕНТЫ

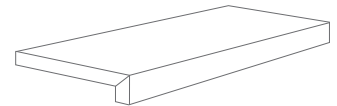

elemento elle rett.

30x60,5x4 (12"x24"x1,5")
7688470 brandy roc rett.
7688490 grigio roc rett.
7688480 nube roc rett.
7688460 bianco roc rett.
116 ▲ 7 ☐

artica roc | 2CM

2,8 PCS / 1 M2							
SUPPORTI FISSI - FIXED SUPPORTS PLOTS FIXES - FIXE STELZLAGER	SUPPORTI REGOLABILI IN ALTEZZA - SUPPORT WITH ADJUSTABLE HEIGHT PLOTS REGOLABLES EN HAUTEUR - STELZLAGER MIT EINSTELLBARER HÖHE						
H 25 mm 19 ▲ 7327019	H 35-50 mm 24 ▲ 7326979	H 50-70 mm 24 ▲ 7326989	H 65-100 mm 26 ▲ 7326999	H 95-130 mm 28 ▲ 7327009	H 125-160 mm 31 ▲ 7327007	H 155-190 mm 32 ▲ 7327008	H 185-220 mm 34 ▲ 7327018

IMBALLI packing - emballages - verpackung - УПАКОВКА

F.TO NOMINALE / NOMINAL SIZE	mm.	PCS / BOX	M2 / BOX	BOX / PLT	M2 / PLT	KG. / PLT
60,5x60,5 Rett.	20	2	0,73	32	23,36	1024



neutra roc 12CM

PAVIMENTI A SECCO PER ESTERNI
DRY-LAID FLOORING FOR OUTDOOR USE
DALLAGES A SEC POUR EXTERIEURS
TROCKENFUSSBÖDEN FÜR AUSSENRAÜME

avorio roc



60,5x60,5 (24"x24")
7685899 rett.

106 ●

≠20

beige roc



60,5x60,5 (24"x24")
7685909 rett.

106 ●

≠20



DIN 51130
R11



DIN 51097
A+B+C

piombo roc

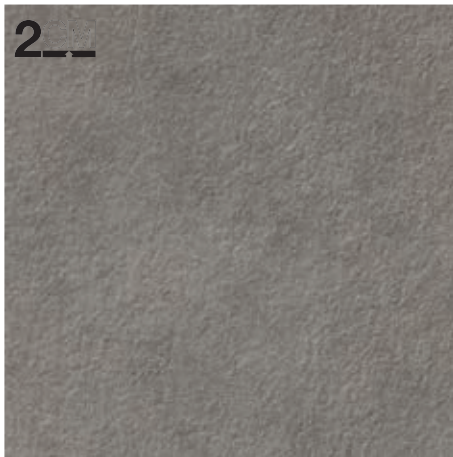

60,5x60,5 (24"x24")
7685919 rett.

106 ●

≠20

nero roc



60,5x60,5 (24"x24")
7685929 rett.

106 ●

≠20

PEZZI SPECIALI

trims
pieces speciales
formstücke
СОБЫЕЭЛЕМЕНТЫ

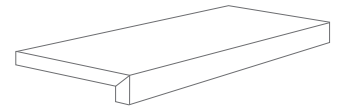

elemento elle rett.

30x60,5x4 (12"x24"x1,5")

7685896 avorio roc rett.

7685906 beige roc rett.

7685927 nero roc rett.

7685916 piombo roc rett.

116 ▲ 7 ☐

2,8 PCS / 1 M2							
SUPPORTI FISSI - FIXED SUPPORTS PLOTS FIXES - FIXE STELZLAGER	SUPPORTI REGOLABILI IN ALTEZZA - SUPPORT WITH ADJUSTABLE HEIGHT PLOTS REGOLABLES EN HAUTEUR - STELZLAGER MIT EINSTELLBARER HÖHE						
H 25 mm 19 ▲ 7327019	H 35-50 mm 24 ▲ 7326979	H 50-70 mm 24 ▲ 7326989	H 65-100 mm 26 ▲ 7326999	H 95-130 mm 28 ▲ 7327009	H 125-160 mm 31 ▲ 7327007	H 155-190 mm 32 ▲ 7327008	H 185-220 mm 34 ▲ 7327018

IMBALLI packing - emballages - verpackung - УПАКОВКА

F.TO NOMINALE / NOMINAL SIZE	mm.	PCS / BOX	M2 / BOX	BOX / PLT	M2 / PLT	KG. / PLT
60,5x60,5 Rett.	20	2	0,73	32	23,36	1024



PAVIMENTI A SECCO PER ESTERNI
DRY-LAID FLOORING FOR OUTDOOR USE
DALLAGES A SEC POUR EXTERIEURS
TROCKENFUSSBÖDEN FÜR AUSSENÄUME

urbandeck grip 2CM

silver grip

grey grip

taupe grip



GM

V3



DIN 51130
R11



DIN 51097
A+B+C

40x120 (16"x47")
7695039 rett.

110 ●

40x120 (16"x47")
7695049 rett.

110 ●

40x120 (16"x47")
7695059 rett.

110 ●

PEZZI SPECIALI trims - pieces speciales - formstücke - СОБЫЕЭЛЕМЕНТЫ

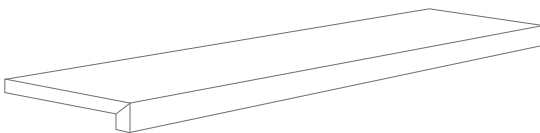

elemento elle rett.

40x120x4 (16"x47"x1,5")
7695038 silver rett.
7695048 grey rett.
7695058 taupe rett.

135 ▲ 2 ☐

IMBALLI packing - emballages - verpackung - УПАКОВКА

F.TO NOMINALE / NOMINAL SIZE	 mm.	 PCS / BOX	 M2 / BOX	 BOX / PLT	 M2 / PLT	 KG. / PLT
40x120 Rett.	20	2	0,96	32	30,72	1444

technical section

sezione tecnica
section technique
Technischer abshnitt
Ктехнический раздел

238	<p>grandi lastre - guida alla posa Large format slabs: Storage – Handling – Installation</p>	260	<p>stuccatura delle fughe joint sealing jointoiment verfugung der fugen estucado de las fugas заделка швов</p>
252	<p>gres porcellanato con colorazione in massa porcelained stoneware with mass colouring gres cerame avec pate coloree durchgefärbtes feinsteinzeug gres porcelánico con coloración en masa фарфоровый керамогранит, окрашенный по всей толщине</p>	261	<p>manutenzione e pulizia di pavimenti e rivestimenti maintenance and cleaning of floors and walls entretien et nettoyage des sols et revêtements instandhaltung und reinigung von fussböden und verkleidungen чистка и уход за напольной и облицовочной плиткой</p>
254	<p>gres porcellanato smaltato glazed gres porcelain gres cerame emaille glasierte feinsteinzeug gres porcelánico esmaltado глазурованный фарфоровый керамогранит</p>	264	<p>condizioni generali di vendita general sales conditions conditions générales de vente allgemeine verkaufsbedingungen condiciones generales de venta общие условия продажи</p>
256	<p>nuove norme iso new iso standards nouvelles normes iso neue iso normen neucas normas iso новые нормы iso</p>	268	<p>2cm informazioni tecniche 2cm technical information 2cm informations techniques 2cm technische informationen 2cm información técnica 2cm техническая информация</p>
257	<p>caratteristiche tecniche di resistenza allo scivolamento anti-slip technical features caractéristiques techniques de résistance au glissement technische eigenschaften der rutschfestigkeit características técnicas de resistencia al deslizamiento технические характеристики сопротивления скольжению</p>	272	<p>think green think green think green think green think green think green</p>
258	<p>massetto di sottofondo e giunti foundation base and joints base en ciment et joints estrich und dehnungsfugen bloques de fondo y juntas подстилающая стяжка и швы</p>	274	<p>leed leed leed leed leed leed</p>
259	<p>posa in opera laying pose verlegung colocación укладка</p>	276	<p>schemi di posa laying solutions schemas de pose verlegungbeispiele композиционные решения</p>

GRANDI LASTRE

GUIDA ALLA POSA

Large format slabs: Storage – Handling – Installation

3200

Porcelain Stoneware

60x120
24"x47"

120x120
47"x47"

160x320
63"x126"

120x260
47"x102"

120x241
47"x96"

INTRODUZIONE / INTRODUCTION

Per *grande formato* si definiscono quelle lastre, quadrate o rettangolari, dove entrambi o solamente uno dei due lati risulta essere maggiore di 60 cm. / Large format refers to square or rectangular slabs where one or both of the dimensions is greater than 60 cm. (UNI 11493-1:2016).

1. **Lo stoccaggio a magazzino e l'imballo / Storage**
2. **La scelta dell'adesivo / Adhesive Selection**
3. **La movimentazione / Handling**
4. **La tecnica di posa / Installation Technique**
5. **Il taglio e la foratura / Cutting and Drilling**

1. MOVIMENTAZIONE E STOCCAGGIO DELLE LASTRE IMBALLATE STORAGE AND HANDLING THE PACKS

Le lastre in formato 60x120, 120x120cm sono fornite disposte su pallet e protette da opportune sponde laterali / gabbie di protezione, che limitano urti accidentali. In fase di stoccaggio in magazzino, possono essere opportunamente sovrapposte per un massimo di 3 o 4 palette, a seconda del formato.

Le lastre in formato 120x240 e 120x260 cm sono fornite in imballi costituiti da casse di legno, che possono essere opportunamente sovrapposte in fase di stoccaggio per un massimo di 5 casse.

La movimentazione delle lastre imballate deve sempre avvenire per mezzo di carrelli elevatori di idonea portata.

Sia i pallet che le casse di legno, devono sempre essere movimentati singolarmente e la lunghezza delle forche deve essere commisurata alle dimensioni dell'imballo (ad esempio, forche lunghe 1,5 m, se il materiale viene movimentato dal lato lungo, oppure 2,5 m, se le movimentate dal lato corto).

Le stesse forche devono poi essere predisposte in posizione di massima apertura, al fine di migliorare la stabilità dell'imballo durante la movimentazione.

60x120, 120x120 cm formats → shipped on pallets with side collars/protective cages. Store in stacks up to a maximum of 3 or 4 pallets, depending on format.

Slabs in 120x240, 120x260 cm format are packed in wooden crates. Store in stacks up to a maximum of 5 crates.

Handle using suitable capacity forklift trucks.

Move single packs: using fork depth suited to the size of the pack (e.g. 2.5 m for crates).

Use maximum fork width when moving → better pack stability.

2. SCELTA DELL'ADESIVO ADHESIVE SELECTION

La corretta scelta e prescrizione del collante è di fondamentale importanza nella posa di grandi formati. Più specificatamente, la migliore tipologia di adesivo deve essere scelta in funzione di:

- **Destinazione d'uso**
- **Condizioni di esercizio**
- **Tipologia di supporto**
- **Dimensione della lastra ceramica**

Di seguito alcuni accorgimenti generali che possono aiutare per selezionare il corretto adesivo:

- in generale, per la posa dei grandi formati su supporti "tradizionali" (ad esempio massetti cementizi) è consigliabile l'utilizzo di un adesivo di classe C2 caratterizzato da alta deformabilità (classe S2).
- per la posa in ambienti con climi freddi o umidi, o durante il periodo invernale quando la temperatura può abbassarsi sotto i 0°C, è consigliabile l'utilizzo di un adesivo a presa rapida (classe F) per facilitare la stagionatura dello strato di allettamento;
- per la posa in ambienti con climi caldi e secchi o con frequente ed abbondante ventilazione, o durante il periodo estivo quando la temperatura può raggiungere valori elevati, è consigliabile l'utilizzo di un adesivo a tempo aperto prolungato (classe E) per evitare che il collante crei la pellicola superficiale, inibendo del tutto il potere adesivo dello stesso. Importante: qualora si crei questa pellicola, è

- opportuno sottolineare che il collante perde ogni potere d'adesione e non può in nessun caso essere utilizzato;
- in virtù del tempo necessario per poter stendere il collante, specialmente per i formati più grandi quali il 120x120, 120x240 e 120x260cm, è normalmente consigliabile prescrivere un adesivo a tempo prolungato sia sul retro della lastra che sul supporto di posa.
 - per la posa su supporti scarsamente porosi (ad esempio, pavimentazioni in grès preesistenti) o con umidità elevata (ma sempre al di sotto dei requisiti dettati dalla normativa UNI 11493-1:2016) è consigliabile l'utilizzo di un adesivo a presa rapida (classe F) per facilitare la stagionatura dello strato di allettamento.
 - nel caso di posa su supporti in gesso, massetti in anidrite o solfato di calcio, è sempre consigliabile prevedere la stesura di un opportuno *primer* precedentemente le operazioni di posa.
 - nel caso di posa a parete in esterno, ove le lastre in ceramica sono sottoposte a sensibili movimenti di contrazione-dilatazione per effetto dei gradienti termici diurni e stagionali, si rende necessario l'utilizzo di un adesivo altamente deformabile, capace di assecondare i naturali movimenti del rivestimento, ammortizzando così le tensioni generate sul sottostante supporto e producendo un rilassamento dello sforzo che evita il distacco del rivestimento ceramico dal supporto.

A titolo indicativo, si riporta di seguito una tabella ove sono indicati i requisiti minimi consigliati per la posa di lastre di grande formato, a seconda dell'ambiente e del tipo di supporto.

Choose adhesive on the basis of:

- **End use**
- **Installation conditions**
- **Support type**
- **Dimensions of ceramic slab**

Indications for adhesive selection

- Traditional supports (cementitious screed) → highly flexible Class C2 adhesives (Class S2)
- Installation in cold, humid climates, during winter → quick setting adhesive (Class F)
- Installation in hot, dry climates with good ventilation, or during summer → adhesive with extended open time (Class E). Installation must be fully complete before the adhesive forms a skin (causing it to lose all adhesive power).
- Installation on low-porosity supports (pre-existing ceramic tile) or under high humidity → fast-setting adhesives (Class F), for more rapid curing;
- Installation on plaster, anhydrite or calcium sulphate screeds → primer prior to installation
- Installation on external walls → Class S2 highly deformable adhesives, for absorption of cladding movement.

Tipologia di supporto Support type	Posa in interno Interior installation		Posa in esterno Exterior installation	
	pavimento floor	parete wall	pavimento floor	parete wall
Massetti cementizi senza sistema di climatizzazione radiante Cementitious screed without radiant heating/cooling	C2 E S1		C2 E S2	
Massetti cementizi con sistema di climatizzazione radiante Cementitious screed with radiant heating/cooling	C2 E S2			
Massetti in anidrite o solfato di calcio, con o senza sistema di climatizzazione radiante Anhydrite or calcium sulphate screed, with or without radiant heating/cooling	C2 E S2		C2 E S2	
Pavimentazioni preesistenti in ceramica o pietra Pre-existing flooring in ceramic tile or stone	C2 F E S2		C2 F E S2	
Parete in calcestruzzo Cement wall		C2 T E S2		C2 T E S2
Intonaco cementizio Cementitious plaster		C2 T E S2		C2 T E S2
Pannelli o superfici in metallo, pannelli e compositi di legno, gomma, resilienti Metal panels or surfaces, wood panels and composites, rubber, resilient materials	R2 T ¹	R2 T ¹	R2 T ¹	R2 T ¹

¹ indicazione di massima. Vista la varietà e le peculiarità di tali supporti, è sempre necessario consultare, prima della scelta, il produttore dell'adesivo.

3. MOVIMENTAZIONE DELLE LASTRE NELLE FASI PRECEDENTI LA POSA / HANDLING

Una volta estratto dall'imballo il cartone e, da esso, la lastra, movimentarla con cura prestando particolare attenzione agli angoli per evitare sbeccature o rotture, seguendo i consigli che di seguito sono meglio esplicitati.

Il numero di operatori addetti alla movimentazione varia in funzione del formato delle lastre stesse. In qualsiasi caso, tutti gli addetti alla movimentazione devono essere sempre muniti di idonei dispositivi di sicurezza e protezione individuali.

Per i formati 60x120 e 120x120 occorrono due operatori. Si segnala che esistono opportune mono o bi-ventose, che facilitano il sollevamento, la movimentazione (e dunque la posa nella fase successiva). Prima di applicare le ventose, è consigliabile utilizzare una spugna bagnata od uno straccio inumidito sia sulla superficie della lastra che sulla ventosa stessa, al fine di eliminare polvere o residui che ne diminuiscono sensibilmente il potere adesivo. L'utilizzo di mono o bi-ventose di tipo Vacuum (ossia a vuoto controllato) è normalmente da preferirsi perché, oltre a consentire una maggiore azione di presa sulla superficie (anche strutturata), consentono in continuo di verificarne l'entità per mezzo del manometro installato. Infine, quattro operatori sono normalmente consigliati per la movimentazione di lastre in formato, 120x240 e 120x260 cm.

In questo ultimo caso, i quattro operatori possono spostare la lastra mediante opportuni telai / profili modulabili (in base al formato della lastra, vedi immagini sottostanti) dotati di ventose. L'utilizzo di ventose tipo Vacuum (a vuoto controllato) è da preferirsi in luogo alle normali bi-ventose in commercio.

Con una spugna bagnata od uno straccio inumidito, eliminare polvere o residui che possono essere presenti sulla lastra ed inumidire tanto la superficie quanto la gomma delle ventose stesse.

Una volta sollevata la lastra, essa deve essere posizionata in maniera stabile su di un supporto che ne consenta la movimentazione in posizione verticale e la successiva spalmatura del collante.

A tale scopo, si segnala che in commercio esistono diverse tipologie di telai verticali movibili, o carrelli, nei quali è possibile incastrare saldamente i profili di sollevamento sopra menzionati. Durante la fase del trasporto della lastra, evitare il più possibile brusche oscillazioni o vibrazioni del materiale. **(1,2)**

Remove boxes from the pack, handling them with care. Be careful of the edges to avoid chips and breakage.

Number of personnel recommended for handling:

- 60x120, → two workers
- 120x120, 120x240, 120x260 → preferably four workers (at least two) using suction cup handling devices

Position the slab in a stable manner on supports, allowing movement into vertical position and subsequent application of adhesive (movable vertical racks). Use of suction cup devices with pressure gauge is recommended → for continuous monitoring of suction grip.

Avoid sudden oscillations and vibration of the material when transporting the slab. **(1,2)**



1



2

4. PRESCRIZIONI GENERALI RIGUARDANTI LA TECNICA DI POSA DEI GRANDI FORMATI INSTALLATION TECHNIQUE

Fatta salva l' idoneità del supporto su cui le lastre saranno installate, una corretta tecnica di posa rappresenta un caposaldo fondamentale da seguire fedelmente al fine di ottenere le migliori performances tecniche da una pavimentazione/rivestimento.

Sia a pavimento che a rivestimento, il requisito fondamentale per una posa a regola d' arte è il raggiungimento del letto pieno d' adesione, vale a dire la condizione in cui lo strato di adesivo tra il retro della lastra ed il supporto di posa è il più possibile continuo, compatto e privo di vuoti. **(3)**

A pavimento, questa condizione permette alla piastrellatura ceramica di resistere alle sollecitazioni meccaniche per le quali è stata progettata. A rivestimento, la condizione di letto pieno assicura una sicura adesione tra ceramica e muratura che eviti distacchi, ribaltamenti, ecc.

La fuga a giunto unito è in generale da sconsigliarsi per ragioni tecniche, prediligendo in ogni caso la posa a giunto aperto **(4)**, particolarmente indicata nel caso di lastre di grande formato o esposte a livelli di sollecitazione meccanica e igrotermica elevati. Questo tipo di posa permette di ridurre sensibilmente il modulo di elasticità della piastrellatura, e quindi la sua rigidità, impedendo in misura relativamente efficace i rischi di sollevamento, distacco o fessurazione delle lastre stesse.

L' interposizione di opportune giunture tecniche (giunti di deformazioni, perimetrali, frazionamento) nelle quali le fughe sono inscritte permette alla pavimentazione di sopportare meglio le sollecitazioni meccaniche e termo-igrometriche a cui la piastrellatura dovrà resistere.

I giunti perimetrali sono posti lungo il confine dell' ambiente da rivestire, ed in corrispondenza di tutti gli elementi della costruzione (pilastri, colonne, tubi).

I giunti di frazionamento a pavimento devono suddividere le piastrellature di grandi dimensioni in campiture di forma approssimativamente quadrata. Interessano tutto lo spessore della piastrellatura (lastra ed adesivo) e parte del supporto, per circa 1/3 del suo spessore.

È consigliabile mantenere un' area massima delle campiture dei giunti di frazionamento pari a 24 / 25 m² in ambienti interni e 9 / 10 m² in ambienti esterni. Il rapporto tra il maggiore ed il minore dei lati della campitura non deve essere maggiore di 1,5.

I giunti di dilatazione interessano esclusivamente lo spessore della piastrellatura (ceramica + adesivo) e devono integrare ed includere la campitura dei giunti di frazionamento per suddividere ulteriormente, laddove ve ne sia bisogno in forza di sollecitazioni meccaniche o termo-igrometriche severe, la piastrellatura in riquadri dilatanti più fitti.

Per dimensionamento della larghezza dei giunti (i cui valori oscillano normalmente tra 5 e 12 mm) si tiene conto delle sollecitazioni meccaniche e termo-igrometriche d' esercizio della piastrellatura e delle capacità elastiche del materiale che costituisce il giunto (in ogni caso, nella realizzazione di tali giunti, è opportuno seguire le indicazioni di fabbricazione fornite dal produttore). **(5, 6, 7)**



3



4



5

Full-bed adhesion: the adhesive layer between slab rear and support is as continuous, compact and free of voids as possible. **(3)** This is achieved by double spreading.

Open-joint installation: always recommended, and especially in locations with high levels of mechanical or hygrothermic stresses **(4)**. Reduces the elastic modulus of the tiling, lessening risks of raising, detachment and cracking in the finished tiling.

Technical joints: the tile edges are inserted in the joints → gaining better support against mechanical and hygrothermic stresses.

Perimeter joints, around the edges of the area to be tiled and against intervening structural elements

Subdivision joints, inserted through the thickness of the slab + adhesive + 1/3 of screed

Expansion joints, inserted only through slab + adhesive

Sizing subdivision joints – area:

- 24 - 25 m² for interior installations
- 9 - 10 m² for exterior installations
- length/width ratio: < 1.5.

Sizing subdivision joints – joint width: on the basis of mechanical and hygrothermic stresses of the tiling installation and elastic capacities of the joint materials. **(5, 6, 7)**



6



7

technical section

4.1 POSA DELLE LASTRE A PAVIMENTO / FLOOR INSTALLATION STEPS

Per effettuare una posa a pavimento a regola d'arte, consigliamo questi passaggi:

- Stendere il collante sul supporto di posa, avendo cura di aver precedentemente verificato che possiede tutti requisiti di qualità necessari per la posa di lastre in grande formato. L'adesivo deve essere steso con una spatola dentata (possibilmente a rebbi inclinati) da 10 mm lungo una sola direzione, preferibilmente quella parallela al lato corto in caso di piastrella rettangolare. Questo accorgimento facilita l'espulsione dell'aria durante la fase di vibrazione e contribuisce ad ottenere il letto pieno d'adesione.
- Stendere il collante sul retro della lastra, con una spatola dentata da 3 mm, nella medesima direzione utilizzata per spalmare il collante sul supporto di posa.
- Movimentare la lastra provvista di strato di adesivo e posizionarla sul supporto di posa ove è stato precedentemente steso il collante.
- Nel caso di posa dei formati 120x120, 120x240 e 120x260 cm è consigliabile l'utilizzo dei predetti carrelli che consentono un trasporto in tutta sicurezza ed aiutano gli operatori a posizionare la lastra in orizzontale. **(8)** In caso di altri formati, la



8

movimentazione ed il posizionamento delle lastre può avvenire tramite mono o bi-ventose e senza l'ausilio di telai preposti. **(9)** Una volta posizionata, muovere delicatamente la lastra, facendo compiere piccoli spostamenti in tutte e quattro le direzioni del piano.

- Nell'effettuare il posizionamento delle lastre adiacenti, rispettare le distanze per le fughe imposte dai distanziatori. A tal proposito, nel caso di lastre di grande formato si consigliano opportuni livellatori che facilitano il processo di allineamento delle fughe ed al contempo aiutano nell'evitare dislivelli tra una lastra e l'altra.

Infine, segnaliamo che vi sono opportuni attrezzi, detti "accosta-lastre" che permettono di effettuare movimenti di precisione per ottenere un corretto posizionamento. **(10)**

Effettuare una opportuna vibrazione utilizzando frattazzi antirimbalzo manuali o vibratori elettrici, partendo dal centro della lastra verso i lati della stessa, su tutta la superficie in maniera continua ed uniforme. **(11)** Questa operazione è necessaria in quanto consente di eliminare i vuoti all'interno dello strato di collante ed aiuta il raggiungimento della condizione di letto pieno d'adesione. Per questa operazione, si consiglia di non utilizzare martelli ancorché gommati.

- Attendere la stagionatura del collante, secondo le indicazioni fornite dal produttore, prima di camminare sopra la superficie della pavimentazione. Per tutto il tempo della stagionatura, la pavimentazione deve risultare protetta da carichi accidentali. Le fughe non stuccate, devono essere protette da polvere e residui.

Spread the adhesive on the installation surface using a 10mm-toothed trowel, working in one direction only (parallel to short side for rectangular slabs).

Spread the adhesive on the rear of the slab using a 3mm-toothed trowel, working in matching direction.

Carefully move the slab into position, placing adhesive against the support surface.

Move the slab delicately, making small movements in all four surface directions.

Use slab-handling tools for precise movement into correct position. **(8, 9,10)**

Vibrate using a manual anti-bouncing tile beater or electric tile vibrator, from slab centre to sides, continuously and uniformly over the entire surface. **(11)**

Wait for adhesive to set according to the manufacturer's instructions before walking on tiled surfaces. Avoid accidental loading of the surface. Protect joints prior to grouting: prevent accumulation of dust and dirt in open joints.



9



10



11

4.2 POSA DELLE LASTRE A RIVESTIMENTO / TIPS FOR WALL INSTALLATION

Per effettuare una posa a rivestimento a regola d'arte, seguire i passaggi già menzionati al capitolo precedente

- Stendere il collante sul supporto di posa, avendo cura di aver precedentemente verificato che possieda tutti requisiti di qualità necessari per la posa di lastre in grande formato. L'adesivo deve essere steso con una spatola dentata (possibilmente a rebbi inclinati) da 10 mm lungo una sola direzione, preferibilmente quella parallela al lato corto della lastra (onde facilitare l'espulsione dell'aria durante la fase di vibrazione ed assicurare il letto pieno d'adesione). Se il rivestimento prevede sistemi di aggancio di sicurezza "a vista", tipo Cp-Kerclip, prima della stesura del collante occorre ancorare i ganci al supporto con opportuni fissaggi di tipo meccanico (tasselli, sparachiodi, etc.) la cui estremità di testa possa essere "annegata" nello strato di adesivo steso **(12)**

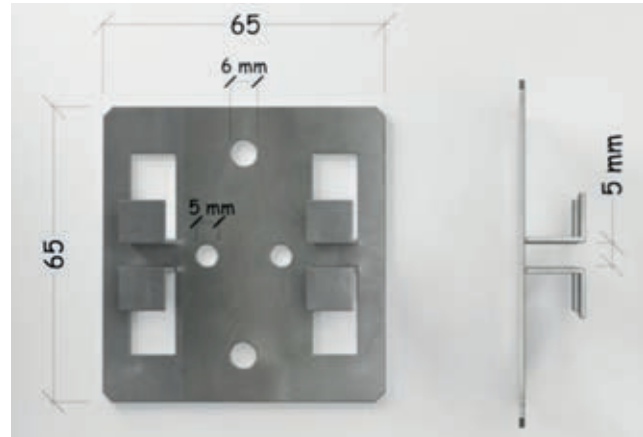

12

- Stendere il collante sul retro della lastra, con una spatola dentata da 3 mm, nella medesima direzione utilizzata per spalmare il collante sul supporto di posa. Se il rivestimento prevede sistemi di aggancio di sicurezza "a scomparsa", tipo Cp-Kerfix, prima della stesura del collante è necessario eseguire l'incisione sul retro della lastra ove sarà alloggiato l'ancoraggio di sicurezza (nel caso in cui tale incisione non sia stata precedentemente effettuata in fabbrica). **(13)**



13

- Nel caso di incisione in cantiere, la distanza reciproca tra le incisioni dovrà essere non inferiore a 40 cm l'una dall'altra e dovrà essere effettuata con opportuni utensili che sono stati appositamente studiati. Dopo l'incisione, e comunque sempre prima della stesura dell'adesivo, occorre incastrare il gancio di sicurezza Cp-Kerfix all'interno della fresatura.
- Movimentare la lastra provvista di strato di adesivo e posizionarla sul supporto di posa ove è stato precedentemente steso il collante. Nel caso di posa dei formati 120x120, 120x240 e 120x260 cm è consigliabile l'utilizzo dei predetti carrelli che consentono un trasporto in tutta sicurezza ed aiutano gli operatori a posizionare la lastra in orizzontale. In caso di altri formati, la movimentazione ed il posizionamento delle lastre può avvenire tramite mono o bi-ventose e senza l'ausilio di telai preposti.
 - Una volta posizionata, muovere delicatamente la lastra, per mezzo del telaio a ventosa, facendo compiere piccoli spostamenti in tutte e quattro le direzioni.

Nell'effettuare il posizionamento delle lastre adiacenti, rispettare le distanze per le fughe. L'utilizzo dei sistemi livellatori è possibile e consigliabile anche nel caso di posa a rivestimento verticale.

- Effettuare una opportuna vibrazione utilizzando frattazzi antirimbazzo "manuali" o vibratorii elettrici, partendo dal centro della lastra verso i lati della stessa, su tutta la superficie in maniera continua ed uniforme. Questa operazione è necessaria in quanto consente di eliminare ogni tipo di vuoto all'interno del letto pieno d'adesione.
- Correggere eventuali difetti di planarità avvalendosi dei sistemi di livellamento in corrispondenza dei distanziali delle fughe.

- Ancorare i ganci del sistema Cp-Kerfix al supporto di posa con opportuni fissaggi meccanici (tasselli, sparachiodi, etc.) la cui estremità di testa possa essere "annegata" nello strato di adesivo steso.
- Attendere la stagionatura del collante, secondo le indicazioni fornite dal produttore, prima di effettuare qualsiasi operazione sul rivestimento (fori, incisioni, etc.) o applicare carichi alla piastrellatura.

If installing wall cladding using (Cp-Kerclip) visible safety systems, anchor the clips to the support prior to spreading the adhesive (using anchors, nailgun, etc.) **(12)**

- If installing wall cladding using (Cp-Kerfix) invisible safety systems, cut the back of the slab prior to spreading the adhesive. If the slab cuts are carried out at the worksite, the distance between cuts must be > 40 cm.
- Carefully move the slab into position, placing the adhesive layer against the support surface. Anchor the Cp-Kerfix clips to the support surface. **(13)**

Wait for adhesive to set according to the manufacturer's instructions before carrying out any cladding operations (holes, cuts, etc.), and before applying any loads to the tiling.

4.3 TAGLIO DELLE LASTRE / CUTTING AND DRILLING

Per il taglio di lastre di grande formato occorre premunirsi di una opportuna attrezzatura che permetta di effettuare tali operazioni in tutta sicurezza, sia per l'incolumità dell'operatore sia per preservare l'integrità della lastra stessa. L'utilizzo di taglierine professionali ad acqua è da preferirsi per ottenere una migliore qualità del taglio **(14,15)**



14

Water cutting, using professional equipment for higher quality cuts. **(14,15)**



15

Nel caso di taglio a secco, a seconda della tipologia di taglio e del formato della lastra, possono essere impiegati diverse varietà di utensili:

- Segnaliamo che in commercio esistono taglierine di dimensioni idonee per tagliare lastre di formato fino al 60x120 cm **(16)**
- Lastre di dimensioni maggiori (ad esempio 120x120, 120x240 e 120x260cm) devono essere posizionate su di un piano rigido e stabile, che possa assorbire eventuali vibrazioni indotte dagli utensili di taglio, il quale può essere effettuato mediante idonee guide già equipaggiate di rotelline diamantate. Le guide devono essere ben ancorate alla lastra. **(17, 18, 19)**
- Qualsiasi sia l'utensile prescelto per effettuare un'operazione di questo genere, al fine di ottenere una linea di taglio ben definita e senza sbavature, si consiglia di controllare preventivamente lo stato di usura della rotellina di incisione e sostituirla, nel caso di usura evidente, con una nuova al widia/titanio o lega di carbonio. L'incisione deve essere progressiva ed uniforme, senza esercitare una eccessiva pressione in alcuni punti, mantenendo una velocità ed una forza costante lungo tutta la linea di incisione.



16



17

18

La fase troncatrice, nel caso di tagli su lastre adagiate su di un piano di lavoro, deve essere effettuata mediante opportune pinze che agiscono, in contemporanea, sulle estremità delle linee di taglio ed una in mezzzeria, in modo da effettuare una pressione di troncatrice quanto più continua lungo tutta l'incisione. **(20, 21, 22)**

- Per effettuare tagli a scasso o riseghe, si può usare una comune smerigliatrice angolare munita di disco diamantato idoneo allo spessore della lastra. Per i formati più grandi, segnaliamo che alcune guide di taglio sono già predisposte per alloggiare la smerigliatrice angolare su di esse, in modo da guidare l'operatore durante la fase di incisione/taglio in maniera precisa e lineare. **(23, 24)**

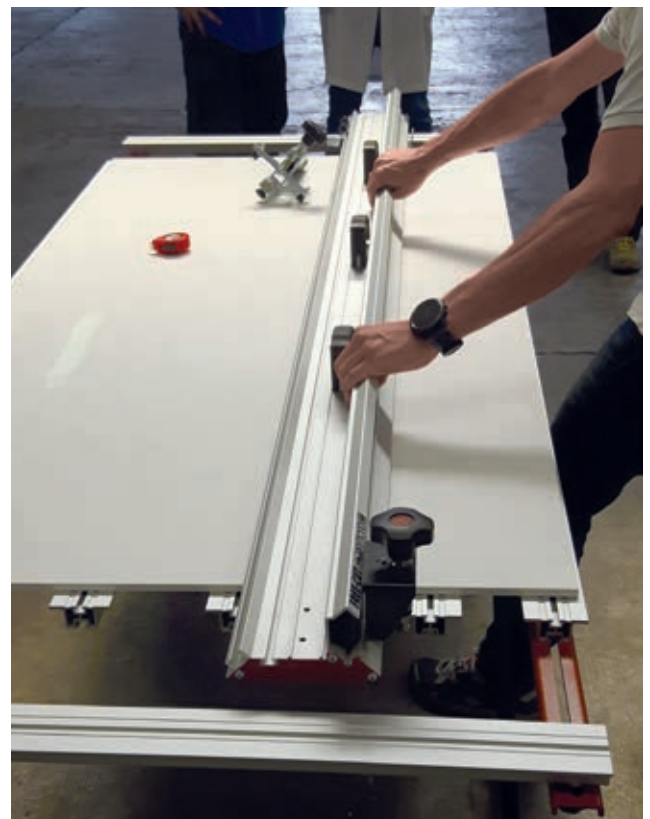

19

- In tutti i casi, si consiglia di dosare la velocità di avanzamento del disco diamantato proporzionalmente alla durezza del materiale: imprimere una velocità eccessiva potrebbe causare il danneggiamento della macchina, la deformazione del disco diamantato e la rottura della piastrella.

Dry cutting - select tools depending on the type of cut and slab format:

- Linear cutters for formats up to 60x120 cm. **(16)**
- 120x120, 120x240 and 120x260 cm formats → cut using a diamond blade with guide on a stable, rigid worktable, capable of absorbing vibrations from cutting tools. **(17, 18, 19)**
- Position the slabs on a solid, stable and rigid surface, capable of absorbing vibrations from cutting tools.
- Anchor the cutting guide to the slab. Most guides come with diamond cutters.
- Cut with uniform pressure, maintaining constant movement and force along the entire line of the cut. **(20, 21, 22)**
- Break using purpose-made pliers, acting simultaneously at the two extremities and at the centre of the cut line.
- Angle grinder with diamond disc for straight-line cuts on medium-large formats **(23, 24)**
- Angle grinder mounted on cutting guide
- Recommendation: advance the diamond disc at speeds suited to the hardness of the material. Going too fast can damage the grinder, deform the diamond disc, and/or break the slab.

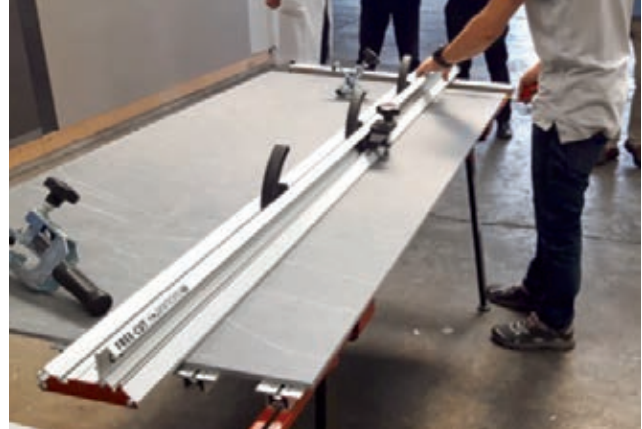

20



21



22



23



24

5. FORATURA DELLE LASTRE /

LINEAR CUTS / POCKET CUT ON WORKTABLE / CIRCULAR HOLES / POCKET CUTS

Di seguito segnaliamo alcuni accorgimenti che permettono di realizzare sulle lastre in grès porcellanato fori e aperture (quadrati o rettangolari) in modo agevole e superando le situazioni più difficili, operando in sicurezza e con professionalità. In tutti i casi, l'operazione deve essere condotta su una superficie piana, stabile, adagiando la piastrella possibilmente su un foglio di polistirolo o di gomma morbida, per attenuare le vibrazioni e rendere più sicuro il lavoro (25). A tal fine, si segnala che in commercio esistono idonei banchi che fungono da supporto durante le operazioni di taglio e foratura, che permettono di effettuare tali operazioni garantendo sicurezza per l'operatore e integrità per la lastra.

La soluzione più rapida per praticare fori circolari su piastrelle in grès porcellanato è quella di ricorrere a frese diamantate professionali applicabili ai comuni flessibili per dischi intercambiabili (disponibili in vari diametri da 6 mm a 75 mm), in grado di realizzare un foro in pochi minuti e lasciando la superficie della piastrella integra e priva di scheggiature sul contorno dell'apertura.

E' importante realizzare il foro facendo oscillare la fresa con movimento rotatorio, senza esercitare eccessiva pressione sul punto d'attacco, avendo l'accortezza di nebulizzare costantemente con acqua il punto esatto ove si vuole realizzare il foro. (26)

La nebulizzazione produce il duplice beneficio di allungare la vita utile della fresa e ridurre l'attrito fresa/ceramica, principale responsabile di eventuali sbeccature e micro-cricche che potrebbero formarsi. Prima di incidere con fresa diamantata, è inoltre consigliabile verificarne lo stato di usura del diamante: frese eccessivamente usurate possono portare a risultati non ottimali. È consigliabile realizzare il foro in più riprese, nebulizzando/bagnando costantemente l'area di incisione

Nel caso di aperture rettangolari o quadrate, la tecnica dell'incisione e taglio con solo disco montato su flessibile (spesso non idoneo al grès porcellanato) risulta oltremodo difficoltosa e dall'esito incerto: lo stress provocato dal taglio e le vibrazioni trasmesse al materiale, in condizioni di lavoro assai precarie come si riscontrano spesso nei cantieri, può provocare fessurazioni e rotture anche dopo l'incollaggio del pezzo.

Nella maggior parte dei casi, il tutto è risolvibile procedendo nel seguente modo:

- seguendo la procedura sopra descritta per la realizzazione dei fori ed utilizzando frese diamantate professionali, realizzare 4 fori del diametro di circa 5-7 mm in corrispondenza dei vertici che delimitano l'apertura, con l'utilizzo di un trapano non a percussione
- incidere delicatamente e progressivamente la piastrella da foro a foro con flessibile e disco diamantato professionale idoneo per grès porcellanato.

Di importanza fondamentale in questa delicata fase di taglio è la qualità e la struttura del disco diamantato che, operando a velocità molto elevata, deve mantenere integre le proprie caratteristiche di rigidità e taglio (27, 28, 29, 30)



25



26



27

Support the slab on a flat, stable surface (worktable, polystyrene or soft rubber sheet) **(25)**

Use professional-quality diamond bits (for use with angle-grinders), 6 to 75 mm diameter.

Rock the cutter bit in a rotating motion, avoiding excessive pressure; apply a constant spray of water. **(26)**

Complete the cutting in steps, spraying/bathing the area of the hole constantly.

Cut 4 holes of about 5-7 mm diameter, corresponding to the borders of the pocket corners. If necessary, cut more holes along the borders of the pocket opening. Cut the slab delicately and continuously from one hole to the next, using angle grinder and professional-quality diamond disc for porcelain tiles **(27, 28, 29, 30)**



28

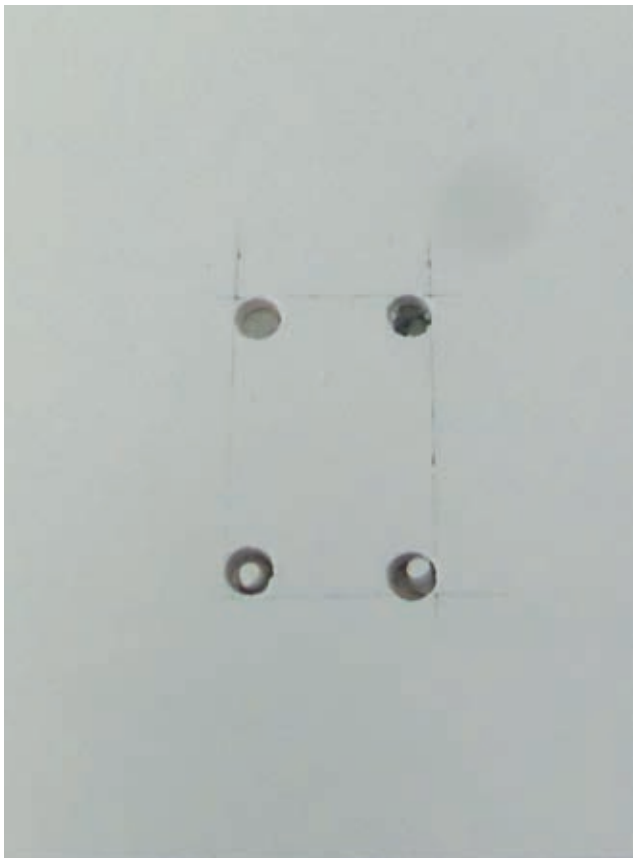

29



30

Movimentazione

Handling/Manipulation/Handhabung

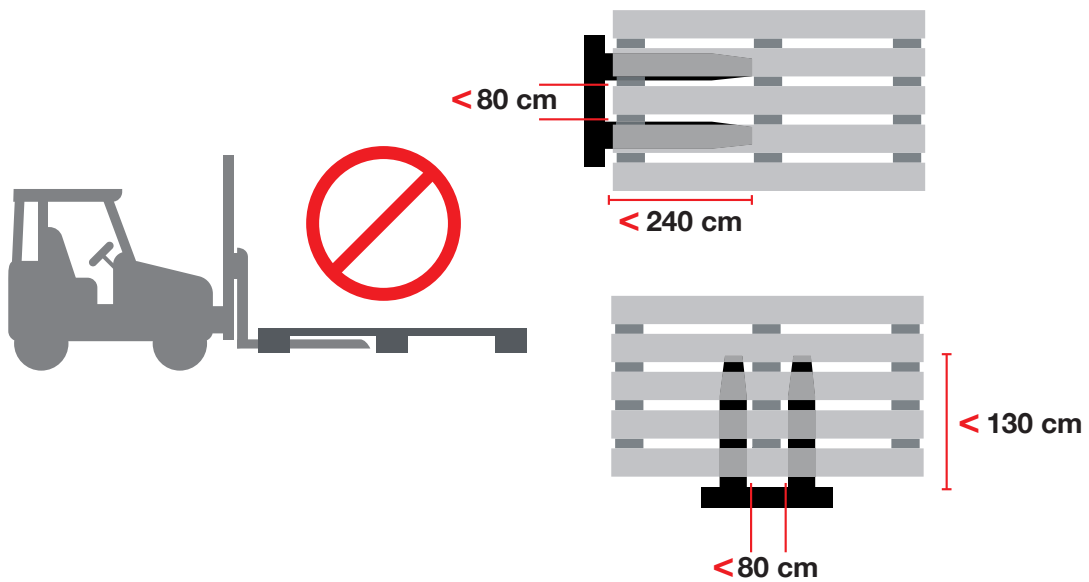
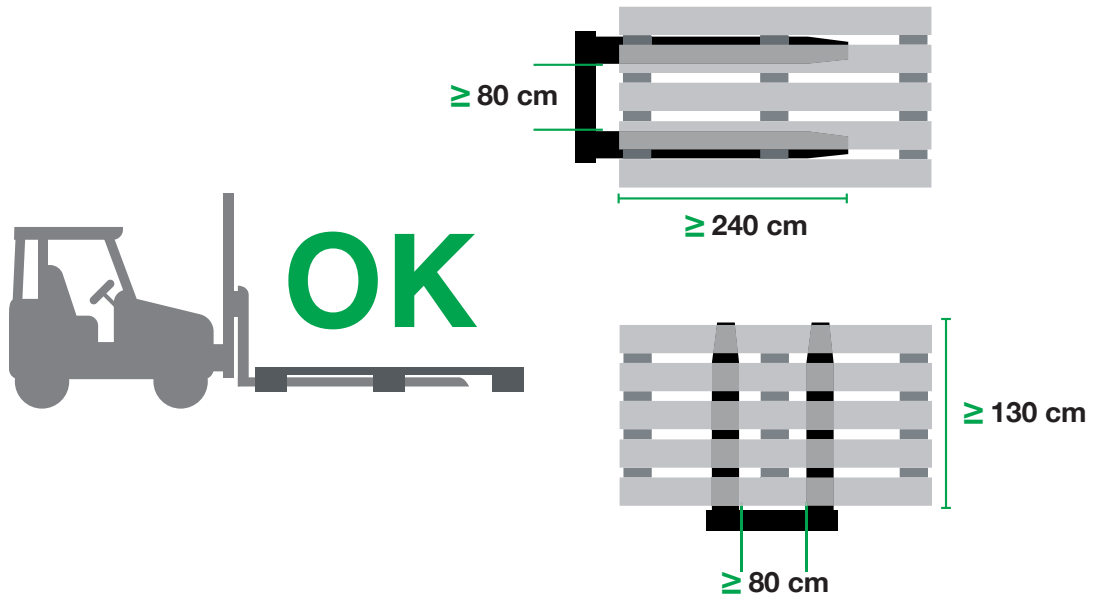

OK

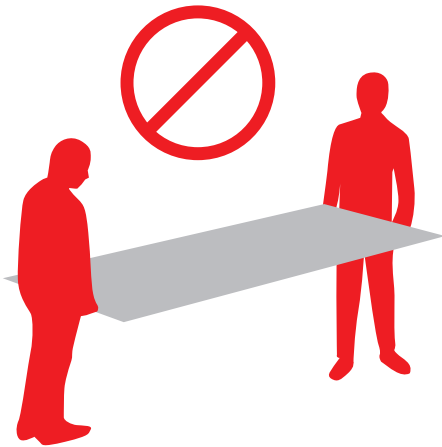
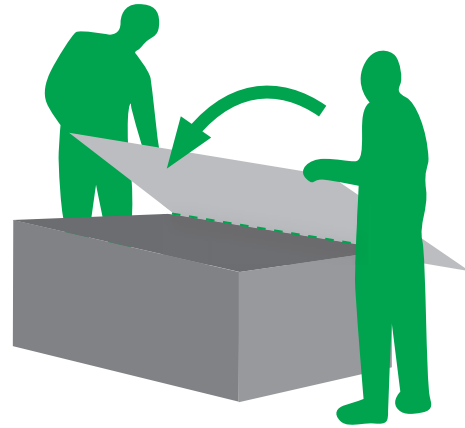
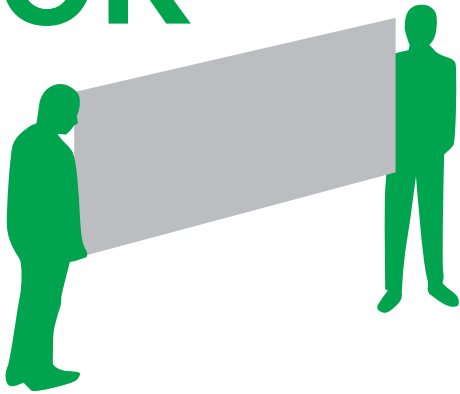

Simbologia Symbolics Symboles Symbole Simbologias Символы	Caratteristiche Features Caracteristiques Eigenschaften Características Характеристика	Unità di misura Unit of measurement Unité de mesure Masseinheit Unidad de medida Единица измерения	GRUPPO DI APPARTENENZA SECONDO ISO 13006		
			Valore medio Saime Saime mean value Valeur moyenne Saime Durchschnittswert-Saime Valor medio Saime Среднее значение Saime	Valore prescritto Fixed value Valeur prescrite Vorgeschriebener Wert Valor prescrito Требуемое значение	Metodo di prova Test method Méthode d'essai Prüfmethode Método de ensayo Метод испытания
	Dimensione lati Dimensions-Lenght and widht Dimensions-Longueur et largeur Masse-Länge und Breite Dimensiones-Longitud y ancho Размеры сторон	%	+/- 0,4	+/- 0,6 max	UNI EN ISO 10545-2
	Rettilineità dei lati Side straightness Rectitude des arêtes Geradlinigkeit der Kanten Rectilinedad de los lados Прямолинейность сторон	%	+/- 0,4	+/- 0,5 max	UNI EN ISO 10545-2
	Ortogonalità degli spigoli Corner squaranness Angularité Rechtwinkligkeit der Kanten Ortogonalidad de las esquinas Ортогональность кромок	%	+/- 0,4	+/- 0,6 max	UNI EN ISO 10545-2
	Planarità Flatness Planéité Ebenflächigkeit Planeidad Плоскость	%	+/- 0,4	+/- 0,5 max	UNI EN ISO 10545-2
	Spessore Thickness Epaisseur Dicke Grosor Толщина	%	+/- 5,0	+/- 5,0 max	UNI EN ISO 10545-2
	Assorbimento d'acqua Water absorption Absorption d'eau Wasseraufnahme Absorción de agua Водопоглощение	%	< 0,2	≤ 0,5	UNI EN ISO 10545-3
	Sforzo di rottura Breaking strenght Contrainte de rupture Bruchkraft Esfuerzo de rotura Разрушающее усилие	N	> 1600	≥ 1300 se Spess. ≥ 7,5 ≥ 700 se Spess. ≤ 7,5	UNI EN ISO 10545-4
	Modulo di rottura Modulus of rupture Coefficient de rupture Bruchmodul Módulo de rotura Модуль разрыва	N/mm ²	> 40	≥ 35	UNI EN ISO 10545-4
	Dilatazione termica lineare Coeff. of linear thermal expansion Coeff. d'extension thermique linéaire Linearer Wärmeausdehnungs-Koeffizient Coeficiente de dilatación térmica lineal Линейное тепловое расширение	°MK (-1)	7,0	metodo disponibile available method méthode disponible verfügbare methode método disponible требуемое значение	UNI EN ISO 10545-8
	Resistenza agli sbalzi termici Thermal shock resistyance Résistance aux chocs termiques Temperaturwechsel Beständigkeit Resistencia a choque térmico Стойкость к перепадам температуры	-	resiste resist widerstandsfähig resiste стойкий	metodo disponibile available method méthode disponible verfügbare methode método disponible требуемое значение	UNI EN ISO 10545-9
	Resistenza alle macchie Stain resistance Résistance au tâches Flecken Beständigkeit Resistencia a las manchas Стойкость к образованию пятен	-	≥ 3	3 MIN	UNI EN ISO 10545-14
	Resistenza ai prodotti chimici di uso domestico Resistance to chemical products Résistance aux produits chimiques Beständigkeit gegen Chemikalien Resistencia a los productos químicos Стойкость к бытовым химикатам	-	conforme conform conforme gleichmässig conforme соответствует	MIN GB	UNI EN ISO 10545-13
	Resistenza agli acidi e alle basi a bassa concentrazione Resistant to acids and low concentration bases Résistance aux acides et aux bases à faible concentration Widerstandsfähig gegenüber niedrig konzentrierten Säuren und Laugen Resistencia a los ácidos y las bases de baja concentración Стойкость к низким концентрациям кислот и щелочей	-	MIN GLB	secondo classificazione prodotto according to product classification selon classification produit Gemäß Produktklassifizierung Согласно классификации продукции	UNI EN ISO 10545-13
	Resistenza al gelo Frost resistance Résistance au gel Frostbeständigkeit Resistencia al hielo Морозостойкость	-	resiste resist widerstandsfähig resiste стойкий	richiesta request demande anfrage solicitud требуемое значение	UNI EN ISO 10545-12
	Stabilità dei colori Colour stability Stabilité des coloris Lichtechtheit der Färbung Estabilidad de los colores Цветостойкость	-	stabile stable stabil estable стойкий	metodo disponibile available method méthode disponible verfügbare methode método disponible требуемое значение	DIN 51094
	E' a disposizione della gentile clientela la lista dei nostri articoli certificati dall'ente UNI CERTIQUALITY The list of our items certified by "UNI" is available for our customers Pour tous nos clients est disponible la liste de nos produits avec la certification UNI Den Kunden steht eine Aufstellung zur Verfügung der Artikeln die mit UNI Zertifikat bescheinigt wurden La lista de nuestros artículos certificados por el Instituto UNI está a disposición de la estimada clientela. Мы можем предоставить в распоряжении наших заказчиков перечень нашей продукции, сертифицированной органом UNI				

gres porcellanato **GM**

con colorazione in massa

Il gres porcellanato è un prodotto tecnico realizzato con argille speciali e materie prime selezionate cotto ad alta temperatura. Molto compatto, altamente sinterizzato, raggiunge per questo, un bassissimo grado di assorbimento e offre ai vari test i più elevati valori tecnologici. L'impasto a tutta massa, può essere miscelato a variegate polveri e ossidi per ottenere superfici venate, rustiche o ad effetti speciali. In questo caso si parla di Gres Porcellanato con colorazione in massa. Per apprezzare le differenze tra superficie naturale e lappato fare riferimento ai campioni reali.

PORCELAINED STONEWARE WITH MASS COLOURING

The porcelained stoneware is a technical product manufactured using kaolin and selected raw materials, fired at a high temperature. It is a very compact, highly sinterized product which for this reason has a very low level of absorption and responds with high technological values to various tests. The massive mixture can be mixed with coloured micro-granules to obtain the Vitrified Massive Stoneware, or it can be blended with various powders and oxides to obtain veined and rustic surfaces or surfaces with special effects. In this case it is called porcelained stoneware with mass colouring. Please refer to the actual samples to appreciate the differences between the natural and the semi-polished surface finish.

GRES CERAME AVEC PATE COLOREE

Le grès cérame est un produit technique réalisé avec des kaolins et des matières premières sélectionnés, cuit à haute température. Très compact, hautement synthésisé, il atteint pour cette raison un très faible taux d'absorption et présente, lors des différents tests, les valeurs technologiques les plus élevées. La pâte à toute épaisseur, peut être mélangée à des micro-granulés colorés pour obtenir des surfaces veinées, rustiques ou à effets spéciaux. Dans ce cas, on parle de Grès Cérame avec pate coloree. Afin d'apprécier les différences entre surface naturelle et lappato veuillez vous référer aux échantillons réels.

DURCHGEFÄRBTES FEINSTEINZEUG

Das Feinsteinzeug ist ein technisches Produkt, das aus Kaolinen und ausgewählten Rohstoffen produziert und das bei hoher Temperatur gebrannt wird. Es ist sehr kompakt und durchgesintert und erreicht daher einen sehr niedrigen Absorptionsgrad und bietet bei den verschiedenen Tests die höchsten technischen Werte. Das Vollstärkengemisch kann zur Erzielung von porphyrisiertem Vollstärkenfeinsteinzeug mit farbigem Mikrogranulat oder zur Erzielung von geäderten, rustikalen Oberflächen oder besonderen Effekten mit Pulvern und Oxyden gemischt werden. In diesem Fall spricht man von durchgefärbtem Feinsteinzeug. Um die Unterschiede zwischen Naturale und Lappato Oberfläche zu erkennen, nehmen Sie bitte Bezug auf die realen Muster.

ФАРФОРОВЫЙ КЕРАМОГРАНИТ ОКРАШЕННЫЙ ПО ВСЕЙ ТОЛЩИНЕ

Фарфоровый керамогранит - это технический материал, изготовленный из специальной глины и отобранного сырья, обожженный при высокой температуре. Он является очень компактным материалом с высокой степенью спекания, поэтому обладает очень низким уровнем поглощения и показывает самые высокие технологические результаты при проведении различных испытаний. Однородную по всей толщине смесь можно смешивать с различными порошками и оксидами в целях получения поверхности с прожилками, специальными эффектами и негладкие поверхности. В таком случае речь идет о фарфоровом керамограните, окрашенном по всей толщине. Для оценки различий между натуральной и притертой поверхностью необходимо сравнить образцы продукции.



N° DI CONCESSIONE PT0219



GS

GRES PORCELLANATO SMALTATO
 GLAZED GRES PORCELAIN
 GRES CERAME EMAILLE
 GLASIERTES FEINSTEINZEUG
 GRES PORCELÁNICO ESMALTADO
 ГЛАЗУРОВАННЫЙ ФАРФОРОВЫЙ КЕРАМОГРАНИТ

GRUPPO DI APPARTENENZA SECONDO ISO 13006
 CLASS
 GROUPE D'APPARTENANCE
 ZUGEHÖRIGKEITSGRUPPE
 GRUPPO DE PERTENENCIA
 ГРУППА ПРИНАДЛЕЖНОСТИ



Bla GL

Simbologia Symbolics Symboles Symbole Simbologias Символы	Caratteristiche Features Caracteristiques Eigenschaften Caracteristicas Характеристика	Unità di misura Unit of measurement Unité de mesure Masseinheit Unidad de medida Единица измерения	Valore medio Saime Saime mean value Valeur moyenne Saime Durchschnittswert-Saime Valor medio Saime Среднее значение Saime	Valore prescritto Fixed value Valeur prescrite Vorgeschriebener Wert Valor prescrito Требуемое значение	Metodo di prova Test method Méthode d'essai Prüfmethode Método de ensayo Метод испытания
	Dimensione lati Dimensions-Lenght and widht Dimensions-Longueur et largeur Masse-Länge und Breite Dimensiones-Longitud y ancho Размеры сторон	%	+/- 0,4	+/- 0,6 max	UNI EN ISO 10545-2
	Rettilineità dei lati Side straightness Rectitude des arêtes Geradlinigkeit der Kanten Rectilinedad de los lados Прямолинейность сторон	%	+/- 0,4	+/- 0,5 max	UNI EN ISO 10545-2
	Ortogonalità degli spigoli Corner squaranness Angularité Rechtwinkligkeit der Kanten Ortogonalidad de las esquinas Ортогональность кромок	%	+/- 0,4	+/- 0,6 max	UNI EN ISO 10545-2
	Planarità Flatness - Planéité Ebenflächigkeit - Planeidad Плоскостность	%	+/- 0,4	+/- 0,5 max	UNI EN ISO 10545-2
	Spessore Thickness - Epaisseur Dicke - Grosor Толщина	%	+/- 5,0	+/- 5,0 max	UNI EN ISO 10545-2
	Assorbimento d'acqua Water absorption - Absorption d'eau Wasseraufnahme - Absorción de agua Водопоглощение	%	< 0,4	≤ 0,5	UNI EN ISO 10545-3
	Sforzo di rottura Breaking strenght Contrainte de rupture Bruchkraft Esfuerzo de rotura Разрушающее усилие	N	> 1500	≥ 1300 se Spess. ≥ 7,5 ≥ 700 se Spess. ≤ 7,5	UNI EN ISO 10545-4
	Modulo di rottura Modulus of rupture Coefficient de rupture Bruchmodul Módulo de rotura Модуль разрыва	N/mm ²	> 38	≥ 35	UNI EN ISO 10545-4
	Resistenza all'abrasione Resistance to abrasion Résistance à l'abrasion Beständigkeit gegen Oberflächenverschleiss Resistencia a la abrasión Сопротивление истиранию	-	secondo la serie	Classe 1-5	UNI EN ISO 10545-7
	Dilatazione termica lineare Coeff. of linear thermal expansion Coeff. d'extension thermique linéaire Linearer Wärmeausdehnungs-Koeffizient Coeficiente de dilatación térmica lineal Линейное тепловое расширение	°MK (-1)	7,0	metodo disponibile available method méthode disponible verfügbare methode método disponible требуемое значение	UNI EN ISO 10545-8
	Resistenza agli sbalzi termici Thermal shock resistyance Résistance aux chocs thermiques Temperaturwechsel Beständigkeit Resistencia a choque térmico Стойкость к перепадам температуры	-	resiste résiste widerstandsfähig resiste стойкий	metodo disponibile available method méthode disponible verfügbare methode método disponible требуемое значение	UNI EN ISO 10545-9
	Resistenza alle macchie Stain resistance - Résistance au tâches Flecken Beständigkeit - Resistencia a las manchas Стойкость к образованию пятен	-	≥ 3	3 MIN	UNI EN ISO 10545-14
	Resistenza ai prodotti chimici di uso domestico Resistance to chemical products Résistance aux produits chimiques Beständigkeit gegen Chemikalien Resistencia a los productos quimicos Стойкость к бытовым химикатам	-	conforme conform conforme gleichmässig conforme соответствует	MIN GB	UNI EN ISO 10545-13
	Resistenza agli acidi e alle basi a bassa concentrazione Resistant to acids and low concentration bases Résistance aux acides et aux bases à faible concentration Widerstandsfähig gegenüber niedrig konzentrierten Säuren und Laugen Resistencia a los ácidos y las bases de baja concentración Стойкость к низким концентрациям кислот и щелочей	-	MIN GLB	secondo classificazione prodotto according to product classification selon classification produit gemäß Produktklassifizierung согласно классификации продукции	UNI EN ISO 10545-13
	Resistenza al gelo Frost resistance Résistance au gel Frostbeständigkeit Resistencia al hielo Морозостойкость	-	resiste résiste widerstandsfähig resiste стойкий	richiesta request demande anfrage solicitud требуемое значение	UNI EN ISO 10545-12
	Stabilità dei colori Colour stability Stabilité des coloris Lichtechtheit der Färbung Estabilidad de los colores Цветостойкость	-	stabile stable stabil estable стойкий	metodo disponibile available method méthode disponible verfügbare methode método disponible требуемое значение	DIN 51094
	E' a disposizione della gentile clientela la lista dei nostri articoli certificati dall'ente UNI CERTIQUALITY The list of our items certified by "UNI" is available for our customers Pour tous nos clients est disponible la liste de nos produits avec la certification UNI Den Kunden steht eine Aufstellung zur Verfügung der Artikeln die mit UNI Zertifikat bescheinigt wurden La lista de nuestros artículos certificados por el Instituto UNI está a disposición de la estimada clientela. Мы можем предоставить в распоряжении наших заказчиков перечень нашей продукции, сертифицированной органом UNI				

technical section

Tutte le caratteristiche tecniche del gres porcellanato smaltato si associano in questa tipologia, ad una profonda ricerca estetica, che ha sviluppato e realizzato una varietà innumerevole di articoli. Il ciclo produttivo ha raggiunto livelli così sofisticati tali da garantire sia dal punto di vista fisico-chimico che cromatico, la perfetta qualità del prodotto commercializzato.

GLAZED GRES PORCELAIN

All the technical features of the glazed porcelained gres are coupled, in this type of products, with careful aesthetic research, which has led to the development and creation of a wide range of items. The production cycle has reached so refined levels that the final product, both physically-chemically and chromatically, has a perfect quality.

GRES-CERAME EMAILLE

Toutes les caractéristiques techniques du grès cérame émaillé sont associées, dans cette typologie, à une recherche esthétique profonde, qui a permis de développer et de réaliser une grande variété d'articles. Le cycle de la production a atteint des niveaux si élevés qu'il est à même de garantir, aussi bien d'un point de vue physico-chimique et chromatique, la parfaite qualité du produit sur le marché.

GLASIERTES FEINSTEINZEUG

Alle technischen Eigenschaften des zu dieser Typologie gehörenden glasiertes Feinsteinzeuges stützen auf einer aufwendigen, optischen Forschungsarbeit, durch die eine Vielzahl an Artikeln realisiert wurde. Der Produktionszyklus hat derart raffinierte Erzeugnisse ermöglicht, daß sowohl physikalisch-chemisch, als auf farblich, die perfekte Qualität des für den Handel bestimmten Produktes erreicht wurden.

ГЛАЗУРОВАННЫЙ ФАРФОРОВЫЙ КЕРАМОГРАНИТ

Все технические характеристики глазурованного фарфорового керамогранита в данной линии сочетаются с глубокими эстетическими исследованиями, благодаря которым были разработаны и созданы многочисленные изделия. Производственный цикл достиг такого уровня совершенства, который гарантирует, как с физико-химической, так и с цветовой точки зрения, отличное качество поступающей в продажу продукции.



N° DI CONCESSIONE PT0219



nuove norme ISO

new ISO standards - nouvelles normes ISO - neue ISO normen - nuevas normas ISO - Новые нормы ISO



DEFINIZIONE E CLASSIFICAZIONE DEFINITION AND CLASSIFICATION - DEFINITION ET CLASSIFICATION DEFINITION UND KLASSIFIZIERUNG - DEFINICIÓN Y CLASIFICACIÓN ОПРЕДЕЛЕНИЕ И КЛАССИФИКАЦИЯ		Tabella 1a Table - Tab. Table - Tabla
CARATTERISTICHE E REQUISITI (specifica tecnica)	GRUPPO - GROUP - GROUPE - GRUPPE - GRUPO - ГРУППА Bla - Blb - Blla - Bllb - Blll	ISO 13006
CHARACTERISTICS AND REQUISITES (technical specifications)	Campionamento e criteri di accettazione Sampling and basis for acceptance - Echantillonnage et critères d'acceptation Musterentnahme und Kriterien für die Annahme - Muestreo y criterios de aceptación Отбор образцов и приемочные критерии	ISO 10545.1
CARACTERISTIQUES ET QUALITES REQUISES (Spécification technique)	Determinazione delle caratteristiche dimensionali e della qualità della superficie Determination of dimensions and surface quality Détermination des caractéristiques dimensionnelles et de la qualité de la surface Bestimmung der Abmessungseigenschaften und der Qualität der Oberfläche Determinación de las características dimensionales y de la calidad de la superficie Определение размерных характеристик и качества поверхности	ISO 10545.2
EIGENSCHAFTEN UND VORAUSSETZUNGEN (technische Beschreibung)		
CARACTERÍSTICAS Y REQUISITOS (especificaciones técnicas)	Determinazione dell'assorbimento d'acqua, della porosità apparente della densità relativa apparente e della densità apparente Determination of water absorption, apparent porosity, apparent relative density and bulk density Détermination de l'absorption d'eau, de la porosité apparente, de la densité relative apparente et de la densité apparente Bestimmung der Wasseraufnahme, der scheinbare Porosität, der scheinbaren relativen Dichte und der scheinbaren Dichte Determinación de la absorción de agua, de la porosidad aparente, de la densidad relativa aparente y de la densidad aparente Определение водопоглощения, кажущейся пористости, удельной кажущейся плотности и кажущейся плотности	ISO 10545.3
ХАРАКТЕРИСТИКИ И ТРЕБОВАНИЯ (технические условия)		
METODI DI PROVA TESTING METHODS METHODES D'ESSAI PRÜFMETHODEN MÉTODOS DE PRUEBA МЕТОДЫ ИСПЫТАНИЯ	Determinazione della resistenza a flessione e della forza di rottura Determination of modulus of rupture and breaking strength - Détermination de la résistance à la flexion et de la force de rupture Bestimmung der Flexionsfestigkeit und der Bruchkraft - Determinación de la resistencia a la flexión y de la fuerza de rotura. Определение прочности при изгибе и разрушающего усилия	ISO 10545.4
	Determinazione della resistenza all'urto mediante misurazione del coefficiente di restituzione Determination of impact resistance by measurement of coefficient of restitution Détermination de la résistance au choc à travers la mesure du coefficient de restitution Bestimmung der Stoßfestigkeit durch Messung des Restitutionsfaktors Determinación de la resistencia a los golpes mediante medición del coeficiente de restitución Определение ударпрочности путем измерения коэффициента восстановления	ISO 10545.5
	Determinazione della resistenza all'abrasione profonda per piastrelle non smaltate Determination of resistance to deep abrasion for unglazed tiles Détermination de la résistance à l'abrasion profonde pour carreaux non émaillés Bestimmung der Tiefenabriebfestigkeit bei nicht glasierten Fliesen Determinación de la resistencia a la abrasión profunda para azulejos no esmaltados Определение сопротивления глубокому истиранию неглазурованной плитки	ISO 10545.6
* In sede di ISO/TC189 si è deciso di eliminare il metodo di determinazione della durezza superficiale secondo la scala Mohs, previsto dalla norma EN101 e di sostituirlo con un nuovo metodo. * According to ISO/TC189 the Mohs scale method of determining surface hardness, prescribed by the EN 101 standard, has been eliminated and substituted with a new method. * On a décidé, pour la ISO/TC189, d'éliminer la méthode déterminant la dureté de surface selon l'échelle de Mohs, prévue par la norme EN 101, et de la remplacer par une nouvelle méthode. * Bei der ISO/TC189 wurde beschlossen, die Bestimmungsmethode der Oberflächenhärte auf der Mohsskala gemäß EN 101 abzuschaffen und durch eine andere Methode zu ersetzen. * En sede de ISO/TC189 se ha decidido eliminar el método de determinación de la dureza superficial según la escala Mohs, previsto por la norma EN 101, y sustituirlo con un nuevo método. * При составлении нормы ISO/TC189 было решено устранить метод определения поверхностной твердости по шкале Мооса, предусмотренный стандартом EN101, и заменить его новым методом. Fonte: Assopiastrelle Formedil / Source : Assopiastrelle Formedil / Source : Assopiastrelle Formedil / Quelle: Assopiastrelle Formedil / Fuente: Assopiastrelle Formedil / Источник: итальянская ассоциация производителей керамической плитки Assopiastrelle	Determinazione della resistenza all'abrasione superficiale per piastrelle smaltate Determination of resistance to surface abrasion for glazed tiles Détermination de la résistance à l'abrasion superficielle pour carreaux émaillés Bestimmung der Oberflächenabriebfestigkeit bei glasierten Fliesen Determinación de la resistencia a la abrasión superficial para azulejos esmaltados Определение сопротивления глазурованной плитки поверхностному истиранию	ISO 10545.7
	Determinazione della dilatazione termica lineare Determination of linear thermal expansion - Détermination de la dilatation thermique linéaire Bestimmung der linearen thermischen Dilatation - Determinación de la dilatación térmica lineal. Определение линейного теплового расширения	ISO 10545.8
	Determinazione della resistenza agli sbalzi termici Determination of resistance to thermal shock - Détermination de la résistance aux écarts thermiques Bestimmung der Thermochockfestigkeit - Determinación de la resistencia a los cambios de temperatura. Определение стойкости к перепадам температуры	ISO 10545.9
	Determinazione della dilatazione dovuta all'umidità Determination of moisture expansion - Détermination de la dilatation due à l'humidité Bestimmung der Dilatation durch Feuchtigkeit - Determinación de la dilatación debida a la humedad. Определение расширения, вызванного влажностью	ISO 10545.10
	Determinazione della resistenza al cavillo per piastrelle smaltate Determination of crazing resistance for glazed tiles - Détermination de la résistance à la craquelure pour carreaux émaillés Bestimmung der Haarrissfestigkeit bei glasierten Fliesen - Determinación de la resistencia al cuarteado para azulejos esmaltados Определение стойкости глазурованной плитки к образованию кракелюра	ISO 10545.11
	Determinazione della resistenza al gelo Determination of frost resistance - Détermination de la résistance au gel Bestimmung der Frostfestigkeit - Determinación de la resistencia a las heladas Определение морозостойкости	ISO 10545.12
	Determinazione della resistenza chimica Determination of chemical resistance - Détermination de la résistance chimique Bestimmung der Chemikalienfestigkeit - Determinación de la resistencia química Определение химической стойкости	ISO 10545.13
	Determinazione della resistenza alle macchie Determination of resistance to stains - Détermination de la résistance aux taches Bestimmung der Fleckenfestigkeit - Determinación de la resistencia a las manchas Определение стойкости к образованию пятен	ISO 10545.14
	Determinazione del piombo e del cadmio ceduto dalle piastrelle smaltate Determination of lead and cadmium given off by glazed tiles Détermination du plomb et du cadmium émanant des carreaux émaillés Bestimmung des von glasierten Fliesen freigesetzten Bleis und Kadmiums Determinación del plomo y del cadmio cedido por los azulejos esmaltados Определение свинца и кадмия, выделяемого глазурованной плиткой	ISO 10545.15
	Determinazione delle differenze di colore Determination of colour differences - Détermination de la différence de couleur Bestimmung der Farbunterschiede - Determinación de las diferencias de color Определение цветовых разниц	ISO 10545.16
	Determinazione del coefficiente di attrito Determination of coefficient of friction - Détermination du coefficient de frottement Bestimmung des Reibungskoeffizienten - Determinación del coeficiente de rozamiento Определение коэффициента трения	ISO 10545.17

caratteristiche tecniche di resistenza allo scivolamento

anti-slip technical features - caractéristiques techniques de résistance au glissement

technische eigenschaften der rutschfestigkeit - características técnicas de resistencia al deslizamiento

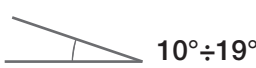
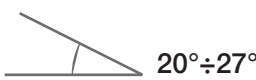
технические характеристики сопротивления скольжению

NORMATIVA TEDESCA DIN 51130 - 51097 GERMAN STANDARD - NORMES ALLEMANDES - DEUTSCHE NORMEN - NORMAS ALEMANAS - НЕМЕЦКИЙ СТАНДАРТ		
DIN 51130		
CATEGORIE DI RESISTENZA ALLO SCIVOLAMENTO CON PIEDI CALZATI SLIP RESISTANCE GROUPS WITH FOOTWEAR - CATEGORIES DE RESISTANCE AU GLISSEMENT LES PIEDS CHAUSSÉS RUTSCHHEMMUNGSKATEGORIEN MIT SCHUHWERK - CATEGORIE DI RESISTENZA ALLO SCIVOLAMENTO CON PIEDI CALZATI КАТЕГОРИИ СОПРОТИВЛЕНИЯ СКОЛЬЖЕНИЮ ПРИ ХОЖДЕНИИ В ОБУВИ		
Coefficiente di Attrito Coefficient of friction Coefficient de friction Reibungskoeffizient Coeficiente de agarre Кэффициент трения	Angoli di Inclinazione Angle Angle d'Inclinaison Neigungswinkel Ángulos de inclinación Углы наклона	Campi di Applicazione Field of application Domaines d'Utilisation Anwendungsbereich Campos de aplicación Сфера применения
R9	 6°÷10°	Ambienti residenziali, scuole, studi medici, ecc. Residential environments, schools, surgeries, etc. Milieux résidentiels, écoles, cabinets de médecins, etc. Wohnbereich, Schulen, Arztpraxen usw. Ambientes residenciales, escuelas, estudios médicos, etc. Жилые помещения, школы, медицинские амбулатории и т.д.
R10	 10°÷19°	Toilettes, magazzini, garages cucine di locali pubblici, ecc. Bathrooms, warehouses, garages, kitchens of restaurants, etc. Toilettes, magasins, garages, cuisines d'établissements publics, etc. Toiletten, Lagerhallen, Garagen, Großküchen usw. Baños, almacenes, garajes, cocinas de locales públicos, etc. Туалеты, склады, кухни общественных заведений и т.д.
R11	 20°÷27°	Lavorazione formaggi, celle frigorifere, lavanderia, ecc. Dairies, cold rooms, laundries, etc. Travail du fromage, chambres frigorifiques, blanchisseries, etc. Käserei, Wäscherei, Kühlräume usw. Elaboración quesos, salas frigoríficas, lavanderías, etc. Сыроваренные цеха, холодильные камеры, прачечные и т.п.
R12	 28°÷35°	Lavorazione carni, cucine industriali, zuccherifici, ecc. Meat processing, industrial kitchens, sugar production, etc. Travail de la viande, cuisines industrielles, sucreries, etc. Fleischverarbeitungstätten, Industrieküchen, Zuckerfabriken usw. Tratamiento de carnes, cocinas industriales, azucareras, etc. Мясоперерабатывающие цеха, промышленные кухни, сахарные заводы и т.д.

DIN 51097		
CATEGORIE DI DESTINAZIONE D'USO PER SUPERFICI CALPESTABILI CON PRESENZA DI ACQUA A PIEDI NUDI SLIP RESISTANCE GROUPS: BAREFOOT ON WET SURFACE - CATEGORIES DE DESTINATION D'UTILISATION POUR SURFACES PIETINABLES EN PRESENCE D'EAU LES PIEDS NUS - BEANSPRUCHUNGSKATEGORIEN FÜR BARFUß BEGEBBARE OBERFLÄCHEN BEI NÄßE CATEGORÍAS DE DESTINO DE USO PARA SUPERFICIES PISABLES CON PRESENCIA DE AGUA CON PIES DESCALZOS КАТЕГОРИИ НАЗНАЧЕНИЯ ПОВЕРХНОСТЕЙ ПРИ НАЛИЧИИ ВОДЫ И ХОЖДЕНИИ БОСИКОМ		
Gruppi di valutazione Evaluation groups Groupes d'estimation Bewertungsgruppen Grupos de valoración Группы оценки	Angoli di Inclinazione Angle Angle d'Inclinaison Neigungswinkel Ángulos de inclinación Углы наклона	Campi di Applicazione Field of application Domaines d'Utilisation Anwendungsbereich Campos de aplicación Сфера применения
A	> = 12%	Spogliatoi, zone di passaggio a piedi nudi, ecc. Dressing rooms, areas likely to be walked on barefoot, etc. Vestiaires, zones de passage les pieds nus, etc. Umkleieräume, Barfuß-Durchgangsbereiche usw. Vestuarios, zonas de paso con pies descalzos, etc. Раздевалки, зоны хождения босиком и т.д.
B	> = 18%	Docce, bordi piscine, ecc. Shower enclosures, swimming pool decks, etc. Douches, bords des piscines, etc. Duschen, Schwimmbadränder usw. Duchas, bordes de piscina, etc. Души, борта бассейнов и т.д.
C	> = 24%	Bordi di piscine in pendenza, scale immerse, ecc. Sloping swimming pool decks, submerged stairs, etc. Bords des piscines en pente, escaliers plongées, etc. Schwimmbadländer mit Gefälle, sich im Wasser befindliche Treppen usw. Bordes de piscina con pendenza, escaleras sumergidas, etc. Наклонные борта бассейнов, погруженные в воду лестницы и т.д.

massetto di sottofondo e giunti

foundation base and joints - base en ciment et joints - estrich und dehnungsfugen

bloques de fondo y juntas - Подстилающая стяжка и швы

Per superfici da pavimentare molto estese, consigliamo di prestare attenzione alla progettazione delle strutture di sottofondo.

Infatti sono da tener conto le seguenti problematiche:

- 1) la dilatazione termica;
- 2) la deformazione o fessurazione dovute al ritiro e asciugamento dei materiali;
- 3) l'assestamento della struttura.

Sottofondi posati in opera su strati comprimibili, esempio isolanti termici, vermiculite o argilla espansa, devono essere armati con rete elettrosaldata.

I massetti possono essere eseguiti in due modi: galleggianti o aderenti. Nel primo caso occorre predisporre una barriera al vapore (foglio polietilico) quindi polistirolo di 1 cm lungo i muri perimetrali e lungo qualsiasi altro elemento che attraversa la pavimentazione. I giunti di frazionamento sono consigliati ogni 5x5 m. Nel caso di massetti aderenti occorre pulire la superficie cementizia, quindi applicare una boiacca di adesione realizzata con cemento, acqua e idonei laticci. Quando quest'ultima è ancora fresca occorre gettare il nuovo massetto aderente. Le informazioni contenute in questo paragrafo sono puramente indicative. Per notizie più approfondite rimandiamo a documentazione specializzata.

For very large floor surfaces we recommend additional care in the design of the foundation structure.

The following factors should be kept in mind:

- 1) Thermal expansion.
- 2) Deformation or cracking caused by shrinkage and drying of the materials.
- 3) The settling of the structure.

Foundations laid on compressible layers, like thermal insulation, vermiculite, or expanded clay must be reinforced with arc-welded meshwork.

The base can be made in one of two ways: floating or fixed. In the first case a vapour barrier must be provided (polyethylene sheet) and then polystyrene of 1 cm along the perimeter walls and along any other element that runs across the floor. Sectional joints are recommended every 5x5 m. In the case of fixed bases, clean the cement surface and apply a fixing grout made from cement, water and suitable latex. When this is still fresh, cast the new fixed laying base. The information contained in this paragraph is purely indicative. For more-in-depth information, we refer you to the special documentation.

Si vous devez carreler des surfaces très étendues, nous vous conseillons de faire très attention au projet des structures de la base en ciment.

Il existe, en effet, des problèmes dont vous devez tenir compte:

- 1) la dilatation thermique;
- 2) la déformation ou les fissures provoquées par le retrait et le séchage des matériaux;
- 3) le tassement de la structure.

Les bases qui sont posées sur des couches compressibles comme, par exemple, des couches d'isolement thermique, de la vermiculite ou de l'argile expansée, doivent être armées de filets soudés électriquement. Les bases de ciment peuvent être effectuées de deux façons: ou bien mobiles ou bien adhérentes. Dans le premier cas, vous devez préparer une barrière à la vapeur (feuille de polythène) et, par conséquent, appliquez du polystyrène d'1 cm le long des murs périmétraux et le long de n'importe quel élément qui traverse le carrelage. Les joints de fractionnement sont conseillés tous les 5x5 m. Dans le cas de bases de ciment adhérentes, vous devez nettoyer la surface en ciment, puis appliquer une bouillie d'adhérence réalisée à base de ciment, d'eau et de latex appropriés. Quand celle-ci est encore fraîche, vous devez jeter dessus la nouvelle base adhérente en ciment. Les informations que contient ce paragraphe sont purement indicatives. Pour des renseignements plus approfondis, consultez la documentation spécialisée.

Bei sehr großen Bodenflächen empfehlen wir, in besonderer Weise auf die Vorbereitung des Untergrunds zu achten.

Dabei muss auf folgendes geachtet werden:

- 1) die thermische Dehnung;
- 2) die Verformung und Rissbildung aufgrund von Schwund und Austrocknung der Materialien;
- 3) die Setzung des Untergrunds.

Untergründe, die auf komprimierbaren Schichten wie Wärmedämmungen, Vermiculit oder Leichtton ausgeführt worden sind, müssen durch Stahlmatten verstärkt werden. Der Estrich kann auf zwei verschiedene Weisen verlegt werden: schwimmend oder aufliegend. Im ersten Fall muss eine Dampfsperre (Polyäthylenfolie) verlegt werden; dann 1 cm Styropor die Wände entlang sowie an allen Baukörpern, die den Boden unterbrechen. Zu allen 5x5 m werden Dehnungsfugen empfohlen. Bei aufliegendem Estrich die Zementoberfläche reinigen, dann eine Haftschrämme aus Zement, Wasser und Latex auftragen. Den neuen Estrich ausführen, wenn die Haftschrämme noch frisch ist. Die in diesem Abschnitt enthaltenen Informationen sind vollkommen unverbindlich. Für weitergehende Informationen verweisen wir auf die entsprechende Dokumentation.

Para superficies muy amplias, que se deben pavimentar, aconsejamos prestar atención al proyecto de las estructuras de base.

De hecho se deben tener en cuenta las siguientes problemáticas:

- 1) la dilatación térmica;
- 2) la deformación o fisuración debidas al retiro y secado de los materiales;
- 3) el asentamiento de la estructura.

Las bases colocadas sobre estratos comprimibles, por ejemplo aislantes térmicos, vermiculita, arcilla expandida, deben ser armadas con red electrosoldada. Los bloques de fondo pueden ser realizados de dos maneras: flotantes o adherentes. En el primer caso es necesario disponer una barrera al vapor (folio de polietileno) a continuación colocar el poliestireno de 1 cm a lo largo de las paredes perimetrales y a lo largo de cualquier otro elemento que atraviese el pavimento. Las juntas de fraccionamiento son aconsejables cada 5x5 m. En caso de bloques de fondo adherentes es necesario limpiar la superficie de cemento, después aplicar una lechada de adhesión realizada con cemento, agua y látex idóneo. Cuando ésta última está todavía fresca es necesario echar el nuevo bloque de fondo adherente. Las informaciones contenidas en este párrafo son puramente indicativas. Para informaciones más detalladas ver documentación especializada.

В случае настила больших поверхностей рекомендуем тщательно спроектировать подстилающие слои.

Необходимо учитывать следующие аспекты:

- 1) тепловое расширение;
- 2) искажение или растрескивание, вызванное усадкой и высыханием материалов;
- 3) оседание конструкции.

Подстилающие слои, уложенные на сжимаемые материалы, например теплоизоляционные материалы, вермикулит или керамзит, необходимо армировать электросваренной сеткой. Стяжки бывают двух типов - плавающие или прилегающие. В первом случае необходимо уложить паронепроницаемый барьер (полиэтиленовую пленку), затем 1 см полистирола вдоль периметра стен и вдоль любого другого элемента, проходящего через пол. Рекомендуется выполнить делительные швы через каждые 5 x 5 м. В случае прилегающей стяжки необходимо сначала очистить бетонную поверхность, затем нанести прилипающий раствор, выполненный из цемента, воды и подходящих латексов. Пока раствор еще не схватился, следует залить прилегающую стяжку. Информация, приведенная в данном разделе, носит лишь ориентировочный характер. Для более подробных сведений смотри специализированную документацию.

posa in opera

laying - pose - verlegung - colocación - Укладка

La posa di un pavimento può avvenire in due sistemi: il primo con una posa a cemento tradizionale, il secondo con l'uso di collanti.

Per il primo caso consigliamo di adottare i seguenti accorgimenti:

- non si deve immergere il materiale in acqua prima della posa;
- spolvero in cemento nella quantità a rifiuto;
- battere il pavimento con l'apposita macchina fino alla fuoriuscita della boiaccia.

Nel secondo caso consigliamo di:

- procedere con l'uso di adesivi;
- preparazione del piano di posa rendendolo sufficientemente planare senza fessurazioni e ben pulito;
- preparazione dell'adesivo attenendosi alle istruzioni del produttore;
- applicazione del collante e posa: applicare con la spatola dentata, coprendo la parte che a mano a mano si va posando.

Le piastrelle andranno appoggiate, con una pressione leggera sulla superficie.

Rimuovere di tanto in tanto per controllare che l'adesivo abbia bagnato sufficientemente il suo rovescio.

Consigliamo sempre una posa con fuga adeguata al tipo di materiale.

Le informazioni contenute in questo paragrafo sono puramente indicative. Per notizie più approfondite rimandiamo a documentazione specializzata.

There are two systems for laying floor tiles: the first with traditional cement, and the second using glue.

In the first case we recommend proceeding as follows:

- do not submerge the material in water before laying,
- sprinkle abundantly with cement,
- pound the floor with an appropriate machine until the grout begins to extrude.

In the case of adhesives we recommend:

- preparing the laying bed so that it is sufficiently flat, free of cracks and very clean,
- prepare the adhesive according to the manufacturer's instructions,
- glue application and laying: apply the glue with a toothed spatula, covering each section as laying proceeds.

The tiles are set in position with a light surface pressure.

We always strongly recommend installation with joints suitable for material being used.

Occasionally remove one to check that the adhesive has sufficiently covered the back of the tile.

The information contained in this paragraph is purely indicative. For more-in-depth information, we refer you to the special documentation.

La pose d'un carrelage peut se faire de deux façons: la première est la pose traditionnelle sur du ciment, la seconde est celle effectuée à l'aide de colles.

Dans le premier cas, nous vous conseillons de faire bien attention aux points suivants:

- vous ne devez pas plonger les carreaux dans de l'eau avant de les poser;
- saupoudrez la bouillie de ciment jusqu'à saturation;
- battez les carreaux à l'aide de la machine conçue à cet effet jusqu'à ce que la bouillie arrive à la surface des carreaux.

Dans le deuxième cas, nous vous donnons les conseils suivants:

- procédez dans l'utilisation des colles;
- préparez la surface sur laquelle les carreaux seront posés: elle doit être suffisamment plate, sans fissures et parfaitement propre;
- préparez la colle en suivant le mode d'emploi du producteur;
- appliquez la colle et posez les carreaux de la façon suivante: à l'aide d'une brosse dentée, appliquez la colle sur la partie de la surface que vous allez recouvrir au fur et à mesure de carreaux.

Posez les carreaux et appliquez une légère pression sur leur surface.

Enlevez un carreau de temps en temps pour vérifier que l'adhésif l'a suffisamment mouillé dessous.

Nous conseillons toujours une pose avec joint adapté au type de matériel.

Les informations que contient ce paragraphe sont purement indicatives. Pour des renseignements plus approfondis, consultez la documentation spécialisée.

Die Verlegung eines Bodenbelags kann mit zwei Systemen erfolgen: das erste ist die herkömmliche Verlegung mit Zementmörtel, das zweite die Verlegung mit Kleber.

Im ersten Fall empfehlen wir die Anwendung der folgenden Maßnahmen:

- Das Material darf vor der Verlegung nicht in Wasser eingetaucht werden.
- Den Untergrund mit reichlich Zement abstreuen.
- Den Bodenbelag mit der entsprechenden Maschine abrütteln, bis die Schlämme austritt.

Im zweiten Fall empfehlen wir:

- Kleber zu verwenden;
- Vorbereitung des Verlegeuntergrunds, der ausreichend eben, frei von Rissen und sauber sein muss;
- Vorbereitung des Klebers unter Beachtung der Angaben des Herstellers;
- Auftragen des Klebers und Verlegung; mit der Zahnpachtel auftragen und nach und nach den Bereich abdecken, der verlegt wird.

Die Fliesen werden mit einem leichten Druck auf die Oberfläche aufgesetzt.

Ab und zu eine Fliese abheben, um zu kontrollieren, ob der Kleber die Rückseite in ausreichender Weise angefeuchtet hat.

Es wird empfohlen eine zum Materialtyp passende Fuge zu verwenden.

Die in diesem Abschnitt enthaltenen Informationen sind vollkommen unverbindlich. Für weitergehende Informationen verweisen wir auf die entsprechende Dokumentation.

La colocación de un pavimento puede realizarse con dos sistemas: el primero con una colocación con cemento tradicional, el segundo con el uso de colas.

Para el primero aconsejamos adoptar las siguientes medidas:

- no se debe sumergir el material en agua antes de la colocación;
- esparcir cemento en polvo hasta la saturación;
- batir el pavimento con la máquina especial hasta que salga la lechada.

En el segundo caso aconsejamos:

- proceder con el uso de adhesivos;
- preparación de la base sobre la que se deben colocar los azulejos, rindiéndola suficientemente plana sin fisuraciones y bien limpia;
- preparación del adhesivo ateniéndose a las instrucciones del productor;
- aplicación de la cola y colocación; aplicar con la espátula dentada, cubriendo la parte que poco a poco se va colocando.

Los azulejos se deberán apoyar, con una presión ligera sobre la superficie.

Levantar de vez en cuando un azulejo para controlar que el adhesivo haya mojado suficientemente la parte de atrás.

Las informaciones contenidas en este párrafo son puramente indicativas. Para informaciones más detalladas ver documentación especializada.

Укладка пола может выполняться двумя способами: традиционным образом, с применением цемента, или же с использованием клеящих составов.

При укладке при помощи цемента рекомендуем придерживаться следующих указаний:

- не погружать материал в воду перед укладкой;
- обильно посыпать пол цементом;
- утрамбовать пол специальной машиной вплоть до вытекания цементного молока.

При использовании клеящих составов рекомендуем выполнить следующее:

- использовать клеящие средства;
 - подготовить поверхность укладки, обеспечивая ее плоскостность, отсутствие щелей и грязи;
 - подготовить клеящий состав с соблюдением инструкции его изготовителя;
 - нанесение клея и укладка: нанести средство зубчатым шпателем, укладывая плитку по мере нанесения клея.
- Плитку следует укладывать, оказывая небольшое давление на ее поверхность.

Время от времени снимайте плитку и проверяйте, что клей намочил в достаточной степени тыльную сторону плитки.

Рекомендуем всегда укладку со швом, соответствующим типу материала.

Информация, приведенная в данном разделе, носит лишь ориентировочный характер. Для более подробных сведений смотри специализированную документацию.

stuccatura delle fughe

joint sealing - jointoiment - verbugung der fugen - estucado de las fugas - Заделка швов

La stuccatura del pavimento posato dovrà avvenire il giorno seguente la posa "a colla". Le fughe dovranno essere perfettamente pulite in tutto il loro spessore; si deve successivamente inumidire con la spugna il bordo delle piastrelle. La fuga può essere eseguita con stucchi cementizi o epossidici preconfezionati. La stuccatura delle fughe viene effettuata con le apposite spatole di gomma, facendo penetrare con particolare cura lo stucco in profondità evitando i vuoti d'aria che possono crearsi. Si lascia asciugare il tutto e quando il sigillante incomincia a far presa, si procede ad asportare l'eccesso con una spugna umida. Per gli epossidici attenersi alle istruzioni del produttore. Nel caso di gres porcellanato levigato è consigliato per la stuccatura sporcare tutta la superficie della piastrella e non utilizzare una colorazione in contrasto con il colore della piastrella. Le informazioni contenute in questo paragrafo sono puramente indicative. Per notizie più approfondite rimandiamo a documentazione specializzata.

The sealing of the laid floor joints should take place the day after laying with glue. The joints must be perfectly clean right across their width. The edges of the tiles should be dampened with a sponge. Joints can be filled with ready-made cement or epoxy filler. The joints are filled using a special rubber spatula, taking great care to ensure the full penetration of the filler and avoiding the formation of air gaps. Leave to dry, and when the filler begins to set, remove the excess with a damp sponge. With epoxy fillers, follow the manufacturer's instructions. When laying polished porcelain stoneware it is advisable to dirty the entire surface of the tile with the filler and not to use a colour that contrasts with the colour of the tiles. The information contained in this paragraph is purely indicative. For more-in-depth information, we refer you to the special documentation.

Le jointoiment du carrelage posé doit se faire le lendemain de la pose "à la colle". Vous devez d'abord nettoyer parfaitement les joints sur toute leur épaisseur et ensuite humidifier le bord des carreaux à l'aide d'une éponge. Le jointoiment peut être effectué avec des stucs en ciment ou avec des stucs oxycarbonés qui se trouvent dans le commerce déjà préparés. Pour effectuer le jointoiment, vous devez utiliser des brosses spéciales en caoutchouc : faites pénétrer le stuc en profondeur en faisant attention à ce qu'il ne se crée pas de vides d'air. Laissez sécher le tout et, quand le scellant commence à prendre, éliminez le stuc excédant à l'aide d'une éponge humide. Pour les oxycarbonés, conformez-vous au mode d'emploi du producteur. Si le carrelage que vous posez est en grès cérame poli, nous vous conseillons d'enduire toute la surface du carreau quand vous effectuez le jointoiment et de pas utiliser une couleur en contraste avec celle des carreaux. Les informations que contient ce paragraphe sont purement indicatives. Pour des renseignements plus approfondis, consultez la documentation spécialisée.

Das Verfugen des verlegten Bodenbelags muss gleich am ersten Tag der Verlegung erfolgen. Die Fugen müssen in der gesamten Breite vollkommen sauber sein und anschließend muss der Rand der Fliese mit einem Schwamm angefeuchtet werden. Die Fuge kann mit Zementstuck oder gebrauchsfertigem Epoxystuck ausgeführt werden. Das Verfugen der Fugen erfolgt mit entsprechenden Gummispachteln, wobei besonders darauf zu achten ist, dass die Masse in die Tiefe eindringt und dass Hohlräume vermieden werden. Alles antrocknen lassen und die überflüssige Masse mit einem feuchten Schwamm entfernen, wenn sie abzubinden beginnt. Bei Epoxymassen die Anweisungen des Herstellers beachten. Bei geschliffenem Feinsteinzeug wird empfohlen, die gesamte Oberfläche der Fliese zu verschmutzen und zum Verfugen eine Farbe zu verwenden, die nicht im Kontrast zur Fliesenfarbe steht. Die in diesem Abschnitt enthaltenen Informationen sind vollkommen unverbindlich. Für weitergehende Informationen verweisen wir auf die entsprechende Dokumentation.

El estucado del pavimento colocado deberá realizarse al día siguiente de la colocación "pegado". Las fugas deberán estar perfectamente limpias en todo su espesor: sucesivamente se debe humedecer con una esponja el borde de los azulejos. La fuga puede realizarse con estucos de cemento o epoxídicos ya preparados. El estucado de las fugas se efectúa con las espátulas especiales de goma, haciendo, con particular cuidado, que el estuco penetre en profundidad evitando los vacíos de aire que puedan crearse. Se deja secar y cuando la masilla impermeable empieza a agarrar, se procede a retirar el exceso con una esponja húmeda. Para los epoxídicos, atenerse a las instrucciones del productor. En caso de gres porcelánico pulido es aconsejable para el estucado, ensuciar toda la superficie del azulejo y no utilizar una coloración en contraste con el color del mismo. Las informaciones contenidas en este párrafo son puramente indicativas. Para informaciones más detalladas ver documentación especializada.

Заделка уложенного при помощи клея пола должна выполняться на следующий день после укладки. Швы необходимо тщательно очистить по всей толщине, после чего необходимо увлажнить губкой кромку плитки. Шов можно выполнить при помощи уже готовых цементных или эпоксидных затирок. Заделку швов необходимо выполнять при помощи специальных резиновых шпателей, очень тщательно обеспечивая проникновение затирки и не допуская образования воздушных пустот. Выдержать материал и, когда клей начнет схватываться, удалить излишки при помощи влажной губки. При применении эпоксидных материалов придерживайтесь инструкций их изготовителя. Если речь идет о полированном фарфоровом керамограните, то для заделки швов рекомендуется намазать всю поверхность плитки, при чем не следует использовать цветную затирку, цвет которой контрастирует с цветом плитки. Информация, приведенная в данном разделе, носит лишь ориентировочный характер. Для более подробных сведений смотри специализированную документацию.

manutenzione e pulizia di pavimenti e rivestimenti

maintenance and cleaning of floors and walls - entretien et nettoyage des sols et revêtements

instandhaltung und reinigung von fussböden und verkleidungen

чистка и уход за напольной и облицовочной плиткой

- Un pavimento o rivestimento murale **Saime Ceramiche** sia nella versione naturale che satinata che lappata o lucida, è sinonimo di bellezza, durata e resistenza nel tempo.

La sua manutenzione non richiede particolari cure se non l'attenersi alle seguenti norme di Pulizia.

Prima pulizia

Si esegue normalmente una sola volta prima dell'utilizzo del pavimento/rivestimento e deve essere obbligatoriamente eseguita dopo la posa in opera e prima dell'uso del pavimento/rivestimento. Ha lo scopo di eliminare ogni traccia di cemento o stucco conseguente alla chiusura dei giunti.

Fughe con stucco cementizio - Lavare il pavimento/rivestimento con un detergente specifico a base acida per ceramica (per i rivestimenti usare un detergente specifico acido in gel).

Fughe con stucco epossidico - È necessario non lasciare residui di prodotti a fine lavoro asportando tutto il materiale, anche se disperso in acqua e asciugando la superficie del manufatto. È consigliabile effettuare un lavaggio con appositi detersivi **entro 24 ore** circa dalla stuccatura e, comunque a stucco indurito all'interno della fuga.

Ovviamente più tempo passa tra la stuccatura già indurita e l'inizio del lavaggio e più **difficoltosa** sarà la pulizia.

Per entrambi i tipi di stucco si procede come di seguito:

1. Spazzare il pavimento/rivestimento raccogliendo lo sporco grossolano.
2. Inumidire con acqua la superficie affinché le fughe vengano impregnate e pertanto protette dall'azione dell'acido del detergente; evitare che il detergente venga a contatto con componenti di acciaio, alluminio e marmo naturale adiacenti al pavimento/rivestimento.
3. Attenersi alla concentrazione del prodotto detergente (rapporto di miscelazione con l'acqua) indicata dal produttore, applicandolo con una spazzola e stenderlo.
4. Durante il tempo d'azione che deve essere stabilito in relazione allo stato del pavimento strofinare lo sporco più ostinato (ad es. residui di malta, stucco, etc...).
5. Sciacquare il pavimento/rivestimento con acqua e raccogliere subito l'acqua sporca (manualmente o con un apparecchio lavasciuga).

L'operazione di prima pulizia, se ritenuto necessario, può essere ripetuta.

Se la prima pulizia viene eseguita dopo che il pavimento/rivestimento è stato usato, sarà bene, prima dell'applicazione del prodotto acido, togliere con appositi detersivi alcalini (**sgrassanti**) eventuali presenze di sostanze grasse o simili (vedi Pulizia ordinaria).

Pulizia ordinaria

Per la pulizia quotidiana è sufficiente lavare il pavimento/rivestimento con acqua e aggiunta di normali prodotti detersivi adatti a pulire superfici ceramiche (per i rivestimenti utilizzare detersivi in gel)

La superficie dei prodotti Saime Ceramiche essendo praticamente inassorbente, non richiede l'applicazione di cere e/o prodotti siliconici di protezione che, al contrario, non devono mai essere usati (possono creare un film superficiale modificando le caratteristiche naturali del grès porcellanato).

Il pavimento deve essere considerato pulito quando riacquista il suo aspetto originario.

Tuttavia in presenza di macchie persistenti e difficili da togliere con la pulizia ordinaria, intervenire con impiego di detergenti più concentrati lasciando agire lo stesso per un adeguato intervallo di tempo e, successivamente, strofinare con più intensità fino a ricondurre le piastrelle all'aspetto originario. Al riguardo è opportuno segnalare che il grès è resistente a qualsiasi sostanza chimica, eccezion fatta per l'acido fluoridrico che attacca tutti i prodotti ceramici e che, quindi, non deve essere utilizzato.

Per la pulizia di pavimenti in aree pubbliche si consiglia di intervenire dopo la chiusura dei locali, affinché il pavimento, alla riapertura, sia asciutto; in alternativa isolare il pavimento pulito fino alla sua completa asciugatura.

Superficie lucida e lappata

Com'è noto tutte le superfici lucide subiscono con l'uso un processo di opacizzazione. Nel caso dei prodotti Saime Ceramiche, grazie alle peculiari caratteristiche tecniche, questo processo di opacizzazione è più lento rispetto a qualsiasi altro materiale naturale (marmo, granito, pietre...). Per conservare tuttavia il più a lungo possibile la lucentezza originale del pavimento è bene proteggere l'ingresso del locale pavimentato, specie se questo è in diretta comunicazione con ambienti esterni, con uno zerbino o altri strumenti idonei al fine di trattenere il più possibile polveri o altre sostanze abrasive al di fuori della pavimentazione.

Una leggera diminuzione della lucentezza, a seguito del primo lavaggio acido del pavimento, deve essere considerata normale, perché dovuta alla eliminazione dei residui degli abrasivi utilizzati nella lavorazione della superficie.

- A Saime Ceramiche floor or wall covering, in the natural, honed, semi-polished or polished version, is synonymous with beauty, durability and resistance over time.

Its maintenance does not require special treatments except for the compliance with the following cleaning rules.

Initial cleaning

This is normally carried out once before the wall/floor tiling is put into use; it must be performed after laying and before using the floor/wall. It aims to remove all traces of concrete or grout following the filling of the joints.

Joints with concrete grout - Wash the floor/wall with a specific acid-based detergent for ceramics (for wall tiles use a specific gel acid detergent).

Joints with epoxy grout - Since no residues must remain after the work, remove all material, even if dispersed in water, and dry the surface of the product. It is advisable to wash with special cleaning agents **within 24 hours** of grouting and anyway when the grout has hardened in the joint.

Obviously the more time that elapses between the already-hardened grouting and the beginning of the wash, the more the cleaning will be difficult.

For both types of grout proceed as follows:

1. Sweep the wall/floor to collect the coarse debris.
2. Moisten the surface with water so that the joints are impregnated and protected from the action of the acid contained in the detergent; prevent the detergent from coming into contact with steel, aluminium and natural marble components next to the floor/wall.
3. Respect the detergent concentration (mixing ratio with water) indicated by the manufacturer, spreading it with a brush.
4. During the exposure time, which must be determined in relation to the state of the floor, scrub the most stubborn dirt (i.e. mortar and grout residues, etc.).
5. Rinse the floor/wall with water and immediately collect the dirty water (manually or with a washer-dryer).

The first cleaning operation, if deemed necessary, can be repeated.

If the first cleaning is performed after the floor/wall has been used, it is a good idea, before applying the acid product, to remove with alkali detergents (degreasing agents) any greasy substances or similar (see Ordinary cleaning).

Ordinary cleaning

For daily cleaning it is sufficient to wash the floor/wall with water adding normal detergents suitable for cleaning ceramic surfaces (use gel detergents for walls).

The surfaces of Saime Ceramiche products, being practically non-absorbent, do not require the application of waxes and/or silicone products which, on the contrary, must never be used (they can create a surface film, changing the natural characteristics of porcelain tiles).

The floor must be considered clean when it regains its original appearance.

However if there are stains which are persistent and difficult to remove with normal cleaning, intervene by using more concentrated detergent, leaving it on for an adequate time interval and then scrub it more vigorously to bring the tiles back to their original appearance. In this respect it should be noted that stoneware is resistant to any chemical substance **with the exception of hydrofluoric acid that attacks all ceramic products and that must therefore never be used.**

In order to clean floors in public areas it is advisable to intervene after the closure of the premises, so that the floor is dry at reopening; alternatively close off the clean floor until it is completely dry.

Honed and semi-polished surface

As we know, all glossy surfaces undergo a process of dulling with use. In the case of Saime Ceramiche products, thanks to their special technical characteristics, this dulling process is slower than in any other natural material (marble, granite, stones, etc.). However, to preserve the original gloss of the floor for as long as possible it is a good idea to protect the entrance to the tiled room, especially if it communicates directly with external environments, with a mat or other appropriate means in order to keep dust or other abrasive substances off the floor as much as possible. A slight decrease in gloss, following the first acid washing of the floor, must be regarded as normal, because it is due to the removal of abrasive residues used in the processing of the surface.

- Un revêtement de sol ou mural Saime Ceramiche en version naturelle, satinato, lappato ou lucido se caractérise par son esthétique, sa longévité et sa résistance dans le temps. Son entretien ne requiert pas de soins particuliers, si ce n'est le respect des règles suivantes en matière de nettoyage.

Nettoyage initial

Il est généralement effectué une seule fois avant l'utilisation du revêtement de sol/mural, et doit obligatoirement être réalisé après la pose et avant l'utilisation du revêtement de sol/mural.

Son but est d'éliminer toute trace de ciment ou tout résidu suite au remplissage des joints.

Jointes ciment - Nettoyer le revêtement de sol/mural avec un produit nettoyant à base acide pour céramique (pour les revêtements muraux, utiliser un gel nettoyant acide spécifique).

Jointes époxy - Aucun résidu de produit ne doit être laissé à l'issue de la pose. Tout résidu, même couvert d'eau, doit être retiré et la surface du revêtement posé doit être séchée. Il est recommandé d'effectuer un nettoyage avec des produits spécifiques dans les 24 heures environ suivant le remplissage des joints, une fois que ceux-ci ont durci.

Bien sûr, plus le temps passe entre le durcissement des joints et le début du nettoyage, plus le nettoyage sera difficile.

Procéder comme indiqué ci-après pour les deux types de joints :

1. Balayer le revêtement de sol/mural en évacuant les saletés les plus grossières.
2. Humidifier la surface avec de l'eau pour imprégner les joints et les protéger de l'action de l'acide du produit nettoyant ; éviter que le produit nettoyant n'entre en contact avec des composants en acier, en aluminium et en marbre naturel adjacents au revêtement de sol/mural.
3. Respecter la quantité de produit nettoyant (rapport de mélange avec l'eau) indiquée par le fabricant et l'appliquer en l'étalant à l'aide d'une brosse.
4. Pendant le temps d'action, à définir en fonction de l'état du sol, frotter les résidus (de mortier, joint, etc.) les plus tenaces.
5. Rincer le revêtement de sol/mural à l'eau et recueillir immédiatement l'eau sale (manuellement ou avec une laveuse-sécheuse de sol).

Si nécessaire, le nettoyage initial peut être répété.

Si le nettoyage initial est effectué alors que le revêtement de sol/mural a déjà été utilisé, il est préférable avant d'appliquer le produit acide d'éliminer les éventuelles substances grasses ou similaires présentes (voir Nettoyage ordinaire) avec des nettoyants alcalins (dégraissants) spécifiques.

Nettoyage ordinaire

Pour le nettoyage quotidien, il suffit de nettoyer le revêtement de sol/mural à l'eau, en y ajoutant des produits nettoyants normaux pour surface céramique (pour les revêtements muraux, utiliser des gels nettoyants).

La surface des produits Saime Ceramiche n'étant quasiment pas absorbante, il n'est pas nécessaire d'appliquer des cires et/ou produits silicones de protection ; au contraire, ceux-ci ne doivent jamais être utilisés (car ils peuvent créer une pellicule superficielle et modifier les caractéristiques naturelles du grès cérame).

Le sol est propre lorsqu'il a retrouvé son aspect d'origine.

En présence de taches persistantes et difficiles à éliminer par un nettoyage ordinaire, utiliser des produits nettoyants plus concentrés en les laissant agir pendant un temps adapté, puis frotter avec plus d'intensité jusqu'à ce que les carreaux aient retrouvé leur aspect d'origine. Signalons à ce sujet que le grès est résistant à toute substance chimique, à l'exception de l'acide fluorhydrique qui attaque tous les produits céramiques et ne doit donc pas être utilisé.

Pour le nettoyage des sols des lieux publics, il est conseillé d'intervenir après la fermeture pour que le sol soit sec au moment de la réouverture ; le cas échéant, isoler le sol nettoyé jusqu'à son séchage complet.

Surface lucida et lappata

Comme on le sait, toutes les surfaces brillantes s'opacifient avec le temps. Grâce aux caractéristiques techniques spécifiques des produits Saime Ceramiche, ce processus d'opacification est plus lent par rapport aux autres matériaux naturels (marbre, granit, pierre, etc.). Pour conserver le plus longtemps possible l'éclat du sol, l'entrée du lieu où il a été posé, en particulier s'il communique directement avec l'extérieur, doit être protégée avec un paillason ou d'autres accessoires permettant de retenir un maximum de poussières ou d'autres substances abrasives.

Une légère diminution de l'éclat du sol après le premier nettoyage acide est normale. Elle est due à l'élimination des résidus des abrasifs utilisés pour le traitement de surface.

- Ein Fußboden oder eine Wandverkleidung von Saime Ceramiche ist sowohl in der Matt als auch in der Satinato, Halbpoliert oder Lucido Version Synonym für unvergängliche Schönheit, Dauer und Resistenz. Die Instandhaltung erfordert keine besondere Pflege, die über die folgenden Reinigungsvorschriften hinausgeht.

Erstreinigung

Sie wird normalerweise nur einmal vor dem Gebrauch des Fußbodens/der Verkleidung vorgenommen und muss auf jeden Fall nach der Verlegung und vor dem Gebrauch des Fußbodens/der Verkleidung erfolgen.

Sie dient zur Beseitigung aller durch das Schließen der Fugen entstandenen Zement- und Stuckspuren.

Fugen mit Zementstuck - Den Fußboden/die Verkleidung mit einem speziellen Reinigungsmittel für Keramik auf saurer Basis reinigen (für die Verkleidungen ein spezielles saures Reinigungsgel verwenden).

Fugen mit Epoxystuck - Nach beendeter Arbeit dürfen keine Rückstände des Produkts zurückbleiben und das gesamte Material muss, auch mit Hilfe von Wasser und durch Trocknen der entsprechenden Fläche, entfernt werden.

Es empfiehlt sich innerhalb von circa 24 Stunden nach der Spachtelung eine Reinigung mit den geeigneten Reinigungsmitteln vorzunehmen, jedoch auf jeden Fall erst wenn der Stuck im Innern der Fuge verhärtet ist.

Je mehr Zeit zwischen der schon verhärteten Spachtelung und dem Beginn der Reinigung vergeht umso schwieriger wird die Reinigung.

Bei beiden Stuckarten wird folgenderweise verfahren:

1. Den Fußboden/die Verkleidung säubern und den groben Schmutz entfernen.
2. Die Oberfläche mit Wasser befeuchten, damit die Fugen imprägniert und somit vor der Wirkung des Reinigungsmittels geschützt werden; es muss vermieden werden, dass das Reinigungsmittel mit Stahl-, Aluminiumkomponenten und natürlichem Marmor in der Nähe des Fußbodens/der Verkleidung in Berührung kommt.
3. Die vom Hersteller angegebene Konzentration der Reinigungsprodukts beachten (Mischungsverhältnis mit Wasser) und mit einer Bürste auftragen und verteilen.
4. In der Einwirkungszeit, die auf Grund des Zustand des Fußbodens festzulegen ist, den hartnäckigsten Schmutz aufwischen (z. B. Rückstände von Mörtel, Stuck etc...).
5. Den Fußboden/die Verkleidung mit Wasser nachspülen und das schmutzige Wasser sofort (bei Hand oder mit einem Bodenreiniger und -trockner) entfernen.

Der erste Reinigungsvorgang kann bei Erfordernis wiederholt werden.

Wenn die Erstreinigung nach Benützen des Fußbodens/der Verkleidung erfolgt, ist es sinnvoll vor dem Auftragen des sauren Produkts mit geeigneten alkalischen (entfettenden) Reinigungsmitteln eventuelle Spuren von Fett oder ähnlichem zu entfernen (siehe normale Reinigung).

Normale Reinigung

Für die tägliche Reinigung ist es ausreichend, wenn der Fußboden/die Verkleidung mit Wasser und einem Zusatz von normalen Reinigungsmitteln für Keramikflächen gereinigt wird (für die Verkleidungen Reinigungsgel verwenden).

Die Oberfläche der Produkte von Saime Ceramiche ist nicht absorbierend, sie erfordert kein Auftragen von Wachs und/oder schützenden Silikonprodukten, die sogar niemals verwendet werden dürfen (sie können einen Oberflächenfilm erzeugen und so die natürlichen Charakteristiken des Feinsteinzeugs verändern).

Der Fußboden gilt als sauber, wenn er wieder sein ursprüngliches Aussehen hat.

Allerdings ist bei hartnäckigen Flecken, die mit der normalen Reinigung schwer zu entfernen sind, der Gebrauch von stärker konzentrierten Reinigungsmitteln sinnvoll. Man lässt sie ausreichend lang einwirken und wischt anschließend kräftig darüber, bis die Fliesen wieder ihr ursprüngliches Aussehen erhalten. Diesbezüglich muss darauf hingewiesen werden, dass das Steinzeug resistent gegen alle chemischen Substanzen ist, mit Ausnahme von Fluorwasserstoffsäure, die alle Keramikprodukte angreift und deshalb nicht verwendet werden darf.

Für die Reinigung von Fußböden in öffentlichen Bereichen empfiehlt es sich nach Schließen des Lokals zu reinigen, damit er Fußboden bei der nächsten Öffnung trocken ist. Als Alternative kann der saubere Fußboden isoliert werden, bis er vollständig trocken ist.

Lucido und Halbpoliert Flächen

Es ist bekannt, dass bei Gebrauch alle blanken Flächen glanzlos werden. Im Vergleich zu anderen natürlichen Materialien (Marmor, Granit, Stein) wird bei den Produkten Saime Ceramiche dieser Prozess verzögert, dank der besonderen technischen Charakteristiken. Um den ursprünglichen Glanz des Fußbodens allerdings so lange wie möglich zu erhalten, besonders wenn er direkt mit Außenbereichen verbunden ist, sollte der Eingang zum Fußboden des Lokals mit einer Fußmatte oder anderen zweckmäßigen Vorrichtungen geschützt werden, um Staub und sonstiges scheuerndes Material nicht auf den Fußboden zu bringen.

Eine leichte Verminderung des Glanzes nach der ersten sauren Reinigung des Fußbodens ist normal, weil sie auf die Beseitigung der Rückstände der bei der Bearbeitung der Oberfläche verwendeten Schleifmittel zurückführbar ist.

- Напольная или облицовочная плитка **Saime Ceramiche**, как в натуральной, так и в сатирированной, шлифованной или полированной версии, является синонимом красоты, долговечности и прочности. Уход за ней не требует выполнения особенных действий, кроме соблюдения следующих правил чистки.

Первая чистка

Как правило, она выполняется один лишь раз, до начала использования пола или облицовки, и должна обязательно выполняться после укладки и до начала использования напольной или облицовочной плитки. Ее целью является удаление всех следов цемента или затирки, которые могут остаться после заделки швов.

Швы с цементной затиркой - Промойте пол или облицовку специальным моющим средством на кислотной основе для керамики (для облицовочной плитки используйте специальный кислотный моющий гель).

Швы с эпоксидной затиркой - Необходимо не оставлять остатков продукта после окончания работ, удаляя весь материал, даже если он растворен в воде, вытирая поверхность насухо.

Рекомендуется промывать специальными моющими средствами **в течение приблизительно 24 часов** после затирки, в любом случае, после отвердевания затирки в шве.

Естественно, чем больше времени пройдет между отвердеванием затирки и началом промывки, тем **сложнее будет выполнять чистку.**

Для обоих типов затирки необходимо действовать следующим образом:

1. Подмести пол или очистить щеткой стены, чтобы собрать крупную грязь.
2. Смочить водой поверхность, чтобы пропитались швы, что защитит их от действия кислоты мощного средства. Не допускайте, чтобы моющее средство попадало на элементы из стали, алюминия и натурального мрамора, которые могут находиться рядом с полом или облицовкой.
3. Соблюдайте указанную производителем концентрацию мощного средства (пропорция смешивания с водой), наносите его щеткой и растирайте.
4. В течение времени действия продукта, которое должно быть установлено в зависимости от состояния пола, потрите наиболее стойкую грязь (напр., остатки раствора, затирки и т.д.).
5. Промойте пол или облицовку водой и сразу же соберите грязную воду (вручную или же пылесосом, собирающим жидкости).

В случае необходимости операции первой чистки можно повторить.

Если же первая чистка выполняется после того, как пол или облицовка уже были использованы, то перед нанесением кислотного продукта рекомендуется удалить специальными щелочными моющими средствами (**обезжиривателями**) возможно присутствующие жирные или схожие вещества (см. Обычную чистку).

Обычная чистка

Для выполнения повседневной чистки достаточно промывать пол или облицовку водой, добавляя в нее обычные моющие средства для чистки керамических поверхностей (для чистки облицовочной плитки используйте чистящие гели).

Поверхность продукции Saime Ceramiche практически не впитывает воду, поэтому, она **не требует нанесения воска и/или силиконовых защитных продуктов, которые, наоборот, никогда не следует использовать (они могут образовывать пленку на поверхности, изменяя естественные характеристики керамогранита).**

Пол должен считаться чистым, когда он приобретает свой первоначальный вид.

Тем не менее, при наличии стойких и трудно выводимых во время обычной чистки пятен действуйте, используя более концентрированные моющие средства, оставляя их на необходимое время, после чего интенсивно потрите, чтобы вернуть плитке первоначальный вид. В этом плане необходимо сказать, что керамогранит является стойким к любому химическому веществу, **кроме фтористоводородной кислоты, которая разрушает все керамические изделия, следовательно, ее нельзя использовать.**

Для чистки полов в общественных местах рекомендуется действовать после закрытия заведения, чтобы в момент открытия пол был сухим. В противном случае пол следует оградить до его полного высыхания.

Полированная и шлифованная поверхность

Как известно, все полированные поверхности, по мере их использования, становятся матовыми. В случае с продукцией Saime Ceramiche, благодаря ее особым техническим характеристикам, матовость образуется медленнее, чем на любом другом натуральном материале (мрамор, гранит, камень). Тем не менее, чтобы как можно дольше сохранить первоначальный блеск пола, рекомендуется защитить вход в помещение, в особенности, если оно выходит непосредственно на улицу, ковриком или другими подходящими средствами, чтобы максимально задерживать пыль или другие абразивные вещества и не допускать их попадания на пол.

Легкое уменьшение блеска после первой промывки пола кислотными средствами должно считаться нормальным, потому что это обусловлено удалением остатков абразивных средств, использованных во время обработки поверхности.

condizioni generali di vendita

general sales conditions - conditions générales de vente - allgemeine verkaufsbedingungen

condiciones generales de venta - Общие условия продажи

1. Premessa

Le presenti condizioni generali, salvo eventuali modificazioni o deroghe concordate per iscritto, disciplinano tutti i contratti di vendita fra noi e l'acquirente. Le variazioni delle condizioni generali di vendita, le transazioni e gli abbouoni, anche se effettuati su iniziativa dei nostri agenti, saranno impegnative per noi solo dopo nostra eventuale conferma scritta e comunque limitate ai contratti a cui si riferiscono.

2. Oggetto della fornitura

La fornitura comprende solamente le prestazioni, i materiali ed i quantitativi specificati nella nostra conferma d'ordine o in altre comunicazioni scritte provenienti da noi. Il testo della nostra conferma d'ordine prevarrà, in ogni caso, sul testo difforme dell'eventuale offerta o della ordinazione.

3. Conferma d'ordine

Qualora nella nostra conferma d'ordine esistano differenze nei singoli elementi che la compongono rispetto alle intese od alle ordinazioni, il compratore che non abbia contestato con lettera raccomandata spedita entro dieci giorni dalla ricezione della conferma tali differenze, è tenuto ad accettarla così come è stata redatta.

4. Consegna

La merce, anche se venduta "franco arrivo", o franco domicilio del compratore, viaggia a rischio e pericolo di quest'ultimo ed ogni nostra responsabilità cessa con la consegna al vettore, nei confronti del quale il compratore - effettuate le opportune verifiche - dovrà sporgere eventuali reclami. L'onere dello scarico della merce dai mezzi di trasporto grava sul compratore. Le spedizioni, via mare o via terra, concernenti forniture sull'estero, vengono effettuate in base alle condizioni scelte di volta in volta, riportate negli "INCOTERMS" approvati dalla Camera di Commercio Internazionale nel 1953 e nei successivi.

5. Termini di consegna

Il termine stabilito per la consegna della merce deve intendersi a favore di entrambi i contraenti.

Salvo l'inserimento di particolari clausole, esso deve di norma considerarsi puramente indicativo e non essenziale. Quando siano intervenute modificazioni al contratto, il termine resta prorogato per un periodo uguale a quello inizialmente stabilito. Ogni evento di forza maggiore sospende la decorrenza del termine per tutta la sua durata. Il ritardo nella consegna della merce, dovuto a cause documentate, anche se non espressamente previste, non dà alcun diritto al compratore di chiedere la risoluzione del contratto, indennizzi o risarcimenti.

6. Pagamenti

Il luogo di pagamento è fissato presso la nostra Sede anche nel caso di emissioni di tratte o ricevute bancarie, ovvero di rilascio di effetti cambiari. Il ritardo, anche parziale, del pagamento delle nostre fatture oltre la pattuita scadenza, darà luogo all'immediata decorrenza degli interessi di mora nella misura dei tassi passivi praticati dagli istituti bancari. Inoltre il mancato o ritardato pagamento delle fatture - per qualsivoglia ragione - ci darà diritto, pregiudicata ogni altra iniziativa, di pretendere il pagamento anticipato delle restanti forniture, oppure di ritenere temporaneamente sospeso o definitivamente risolto il contratto e di annullare l'evasione di eventuali altri ordini in corso, senza che il compratore possa avanzare pretese di compensi, indennizzi od altro. Nessuna eccezione, salvo quella di nullità, annullabilità e rescissione del contratto, può essere opposta dall'acquirente, al fine di ritardare od evitare il pagamento.

7. Riserva di Proprietà

Nel caso in cui il pagamento, per accordi contrattuali, debba essere effettuato - in tutto o in parte - dopo la consegna, i prodotti consegnati restano di nostra proprietà fino all'integrale pagamento del prezzo.

8. Garanzia

La nostra garanzia è limitata ai materiali di 1a scelta, con la tolleranza del 5% (cinqueper cento) circa. Qualsiasi garanzia per vizi rimane quindi espressamente esclusa per i materiali di 2a e di 3a scelta o di stock che, come le partite occasionali, si intendono sempre vendute come "viste" e "piaciute".

Le differenze di tonalità non possono essere denunciate come vizio di materiale. Eventuali reclami e contestazioni dovranno essere notificati, a pena di decadenza, a mezzo lettera raccomandata, unicamente presso la nostra Sede, prima della posa in opera del materiale e comunque nei termini di legge. La posa in opera del materiale determina la decadenza dall'azione per vizi tanto palesi che occulti, importando rinuncia implicita alla garanzia di cui all'art. 1490 c.c. In ogni caso la nostra garanzia comprende unicamente la sostituzione del materiale riscontrato difettoso con esclusione di ogni ulteriore e diversa obbligazione.

Non ci assumiamo nessuna responsabilità sull'idoneità del materiale all'uso cui il compratore lo intende destinare e ciò neppure nell'ipotesi che, da parte nostra, vengano forniti suggerimenti o indicazioni circa l'installazione e l'impiego dello stesso.

9. Marchi commerciali

Il distributore deve utilizzare i nomi ed i marchi commerciali, i logos, ed i domini di cui è titolare esclusiva e fa uso la Nuova Riwal Ceramiche S.r.l. al solo fine di pubblicizzare e vendere i prodotti contrattuali. Tanto il nome Riwal Ceramiche quanto ogni altro nome o marchio commerciale, logos e dominio adottati da Nuova Riwal Ceramiche S.r.l. non dovranno comparire nella ditta, nella ragione sociale o denominazione sociale o nell'oggetto sociale del distributore anche in combinazione di parole. Il distributore non depositerà o farà depositare nè userà in alcun modo marchi, nomi, o altri segni distintivi che assomiglino graficamente, foneticamente o in qualsiasi altro modo ai marchi e nomi commerciali che fanno capo alla Nuova Riwal Ceramiche S.r.l. e si asterrà da qualsiasi comportamento che possa comunque arrecare pregiudizio alla Nuova Riwal Ceramiche S.r.l.

10. Foro competente

Per qualsiasi controversia, comunque relativa alla fornitura, tanto da parte del venditore come da parte del compratore, viene attribuita competenza, con applicazione della legge italiana, al tribunale di Modena.

11. Clausola arbitrale

Per le forniture all'estero, tutte le controversie eventualmente derivanti dal contratto, saranno risolte in via definitiva secondo il regolamento di conciliazione e di arbitrato della Camera di Commercio Internazionale da uno o più arbitri, in conformità a detto regolamento. Ferme le condizioni generali che precedono, il diritto sostanziale applicabile sarà quello esclusivamente italiano.

1. Premise

These general conditions, unless modified or extended and then expressly agreed upon in writing, shall govern all the sales agreements between Gruppo RI.WAL Ceramiche and the purchasers. All transactions, variations to the general sales conditions, as well as discounts, even if such offers are made by our agents, shall be binding for RI.WAL only after its written confirmation and, in any case, shall be limited by the agreements they refer to.

2. Supply

The supply includes the services, the materials and the quantities stipulated in our order acknowledgement or in other means of written communication provided by RI.WAL.

However, the text of our order confirmation will supersede any different text contained in the previous offer or order.

3. Order confirmation

If there are any differences between the elements in the order confirmation and those in the order or those agreed beforehand and the purchaser does not object to them within 10 days by means of a recorded delivery letter, this latter shall be obliged to accept the order confirmation as it stands.

4. Delivery

The goods, even if sold "free at destination" i.e. with carriage to the purchaser paid, shall travel at this latter's risk and all our responsibilities towards the purchaser cease when the goods are handed over to the carrier, to whom the purchaser, after carrying out the necessary checks, should make any claims. It is the purchaser's duty to unload the goods from the means of transport.

Any deliveries made, either by sea or by land, to purchasers abroad are made under the conditions chosen on each occasion, indicated by the 'Incoterms' and subsequent amendments as approved by the International Chamber of Commerce in 1953.

5. Delivery terms

The terms established for the delivery of the goods must be considered beneficial to both parties. Unless extra clauses are provided for, it is standard to consider the terms as simply indicative and not binding. When the agreement is modified, the term is extended by the same amount of time as originally set. In any events of circumstances beyond our control, the delivery term will be suspended for the entire duration of such events. Delays in delivery whose causes can be proved by documentation, even though not expressly provided for, do not result in the purchaser's right to terminate the contract, or to apply for indemnities or damages.

6. Payments

The place of payment is fixed as our head office, even if bank drafts or receipts or bills of exchange are issued. Delays, even partial, in the payment of our invoices (as per the expiry terms agreed upon) shall result in the immediate application of arrears interest, which shall be calculated according to the current bank overdraft rates. Furthermore, failure to pay or delays in payment of the invoices - for any reason - shall give us the right, with no prejudice to further actions, to claim advanced payment for the rest of the supply, or to consider the agreement suspended temporarily or terminated definitively and to annul all orders being processed at that time, without the purchaser being entitled to compensation, indemnities or suchlike. No exceptions, except the rights to nullity and to terminate and withdraw from the agreement, can be opposed by the purchaser in order to delay or avoid payment.

7. Property conditions

If, through contractual agreements, the payment must be made, either in part or in full, after delivery, the products delivered, remain our property until the payment has been made in full.

8. Guarantee

Our guarantee is limited to the 1st choice materials, with a tolerance of approximately 5% (five percent). Any guarantee for defects is therefore expressly excluded for 2nd and 3rd choice materials or discounted stock which, as occasionally happens, are always sold as 'seen and approved'. Tonal differences cannot be disputed as material defects.

Any claims or complaints must be made in writing, at the risk of forfeiture, and they must be sent via recorded delivery mail to our head offices only. This must be done before the material is laid, within the terms set by law. The laying of the material represents the forfeiture of the right to claim for defects, both clearly visible ones and hidden ones, resulting in the implicit waiving of the guarantee as per article 1490 of the Italian Civil Code. In any case, our guarantee only extends to the replacement of the materials found to be faulty, with the exclusion of any further or different obligation.

We cannot accept any responsibility regarding the suitability of the material for the use to which the purchaser puts it, not even if we supply the material with indications or suggestions concerning the installation and use of the material itself.

9. Competent authority

For any disputes, relating to the supply, either from the seller or the buyer, shall be dealt with by the court of Modena and the case shall be governed by the Italian law.

10. Arbitration clause

For foreign supplies, any disputes which may arise from the agreement shall be resolved definitively according to the regulations of conciliation and arbitration of the International Chamber of Commerce, by one or more arbitrators, in compliance with the said regulations. The aforementioned general conditions accepted, the Italian law shall govern this agreement.

11. Commercial Trademarks

The distributor must only use the names, the commercial trademarks, the logos, and the dominion of Nuova Riwal Ceramiche S.r.l., who has the exclusive rights with regards to the their use, for the publicising and sale of its contractual products. Both the name Riwal Ceramiche as well as every other name, commercial trademark, logo, dominion or mixture of these words adopted by Nuova Riwal Ceramiche S.r.l. must not appear in the company style, the corporate or in the social name or in the company aim of the distributor. The distributor will not use, deposit or allow the filing of the trademarks, names, or other distinctive signs that resemble graphically, phonetically or in any other way the trademarks and commercial names which are owned by Nuova Riwal Ceramiche S.r.l. and he will forgo any behaviour that may cause harm to Nuova Riwal Ceramiche S.r.l.

condizioni generali di vendita

general sales conditions - conditions générales de vente - allgemeine verkaufsbedingungen

condiciones generales de venta - Общие условия продажи

1. Avant-propos

Les présentes conditions générales de vente disciplinent tous les contrats de vente entre l'acheteur et nous, sauf éventuelles modifications ou dérogations fixées par écrit. Les changements de ces conditions de vente, les transactions et les rabais, même s'ils sont effectués par initiative de nos agents, ne nous engagent qu'après une confirmation écrite de notre part et sont en tout cas limités aux contrats auxquels ils se réfèrent.

2. Objet de la fourniture

La fourniture comprend uniquement les services, les matériaux et les quantités qui sont spécifiés dans notre confirmation de commande ou dans d'autres communications écrites venant de nous. Le texte de notre confirmation de commande prévaudra, de toute façon, sur le texte éventuellement différent de l'offre ou de la commande.

3. Confirmation de commande

Si dans notre confirmation de commande il existe des différences dans les parties qui la composent par rapport aux accords ou aux commandes, l'acheteur qui n'a pas contesté ces différences par lettre recommandée dans les dix jours à compter de la date de réception de la confirmation est tenu à l'accepter telle qu'elle a été écrite.

4. Livraison

La marchandise voyage aux risques et périls de l'acheteur, même si elle est vendue "franco arrivée" ou "franco domicile de l'acheteur" et notre responsabilité cesse à partir du moment où nous remettons la marchandise au transporteur. C'est à ce dernier que l'acheteur devra faire d'éventuelles réclamations après avoir effectué les vérifications appropriées. Les frais de déchargement de la marchandise des moyens de transport sont à la charge de l'acheteur. Les expéditions par mer ou par terre des fournitures vers l'étranger sont effectuées sur la base des conditions choisies à chaque fois parmi celles indiquées dans les "INCOTERMS" approuvées par la Chambre de Commerce Internationale en 1963 et dans les suivantes.

5. Délais de livraison

Le délai établi pour la livraison de la marchandise doit s'entendre en faveur des deux contractants. A part l'introduction de clauses particulières, il doit être considéré normalement comme purement indicatif et non essentiel. Si le contrat a subi des modifications, le délai est prorogé d'une période égale à celle établie initialement. Tout événement de force majeure suspend le point de départ du délai pour toute sa durée. Tout retard dans la livraison de la marchandise dû à des causes documentées, même si elles n'ont pas été expressément prévues, ne donne aucun droit à l'acheteur de demander la résiliation du contrat, des indemnités ou des dédommagements.

6. Paiements

Le lieu de paiement est le siège de notre société, même en cas d'émission de traites ou de récépissés sur banque, c'est-à-dire de remise de lettres de change. Le retard, même partiel, du paiement de nos factures par rapport au délai convenu, donnera lieu à l'immédiat démarrage du calcul des intérêts moratoires dans la mesure des taux passifs pratiqués par les établissements bancaires. En outre, le non-paiement ou le retard dans le paiement des factures - quelle qu'en soit la raison - nous donnera le droit, toute autre initiative étant en suspens, de prétendre le paiement anticipé des autres fournitures, ou bien de considérer temporairement suspendu ou définitivement résilié le contrat et d'annuler l'expédition des autres commandes éventuellement en cours, sans que l'acheteur puisse avancer des prétentions de dédommagements, d'indemnités ou autres. Aucune exception, sauf celle de nullité, d'annulation et de résiliation du contrat, ne peut être opposée par l'acheteur pour retarder ou éviter le paiement.

7. Réserve de propriété

Si, suite à des accords contractuels, le paiement doit être effectué - totalement ou partiellement après la livraison, nous restons propriétaires des produits livrés jusqu'au paiement intégral du prix.

8. Garantie

Notre garantie est limitée aux matériaux de 1er choix, avec une tolérance de 5% (cinq pour cent) environ. Toute garantie pour des défauts reste donc expressément exclue pour des matériaux de 2e et de 3e choix ou pour des stocks qui, comme les lots occasionnels, s'entendent toujours vendus tels quels. Les différences de nuances ne peuvent être considérées comme défauts du matériau. Les réclamations et contestations éventuelles doivent être notifiées, sous peine de déchéance, par lettre recommandée, envoyée à l'adresse de notre société, avant que le matériau ne soit posé et en tout cas dans les termes de la loi. La pose du matériau implique la déchéance de l'action pour défauts, aussi bien visibles que cachés, et comporte le renoncement implicite à la garantie visée par l'art. 1490 du code civil italien.

Quoi qu'il en soit, notre garantie ne comprend que le remplacement du matériau défectueux et n'inclut aucune autre obligation. Nous déclinons toute responsabilité sur l'adaptabilité du matériau à l'usage que l'acheteur veut en faire, même dans le cas où nous aurions nous-mêmes donné des conseils ou des indications sur l'installation et l'emploi du matériau.

9. Tribunal compétent

Pour tout différend relatif à la fourniture, aussi bien de la part du vendeur que de la part de l'acheteur, c'est au tribunal de Modène qu'est attribuée la compétence en conformité avec la loi italienne.

10. Clauses d'arbitrage

Pour les fournitures à l'étranger, tous les différends dérivant éventuellement du contrat seront résolus d'une manière définitive suivant le règlement de conciliation et d'arbitrage de la Chambre de Commerce Internationale par un ou plusieurs arbitres, en conformité avec ledit règlement. Les conditions générales qui précèdent restant entendues, le droit substantiel applicable sera exclusivement le droit italien.

11. Marques commerciales

Le distributeur doit utiliser les noms et les marques commerciales, les logos et les domaines dont la société Nuova Rival Ceramiche S.r.l. est propriétaire et qu'elle emploie, uniquement dans le but de publiciser et de vendre les produits contractuels. Le nom de Rival Ceramiche ainsi que tout autre nom ou marque commerciale, logos et domaine adoptés par Nuova Rival Ceramiche S.r.l. ne devront apparaître dans le nom de la firme, la raison sociale, la dénomination sociale ou dans l'objet social du distributeur, même dans une combinaison de mots. Le distributeur ne pourra déposer, faire déposer ou utiliser de quelque manière que ce soit des marques, noms ou autres signes distinctifs qui ressemblent graphiquement, phonétiquement ou de toute autre façon aux marques et noms commerciaux appartenant à Nuova Rival Ceramiche S.r.l.. Il s'abstenra en outre de tout comportement pouvant porter préjudice de quelque façon que ce soit à Nuova Rival Ceramiche S.r.l.

1. Vorbemerkung

Die vorliegenden Allgemeinen Bedingungen regeln vorbehaltlich schriftlich vereinbarter Änderungen oder Abweichungen alle Verkaufsverträge zwischen uns und dem Käufer. Die Änderungen der Allgemeinen Verkaufsbedingungen, die Transaktionen und die Gutschriften sind - auch falls sie auf Veranlassung unserer Handelsvertreter vorgenommen werden - nur dann für uns verbindlich, falls sie von uns schriftlich bestätigt worden sind, und sind in jedem Fall ausschließlich auf die Verträge beschränkt, auf die sie sich beziehen.

2. Gegenstand der Lieferung

Die Lieferung umfasst nur die auf unserer Auftragsbestätigung oder sonstigen schriftlichen Mitteilungen von uns aufgeführten Leistungen, Materialien und Mengen. Der Text unserer Auftragsbestätigung hat in jedem Fall Vorrang vor dem gegebenenfalls abweichenden Text des Auftrags oder der Bestellung.

3. Auftragsbestätigung

Falls unsere Auftragsbestätigung bei einzelnen Positionen, aus denen sie sich zusammensetzt, Abweichungen von den Vereinbarungen oder den Bestellungen aufweist, so ist der Käufer, der diese nicht innerhalb von zehn Tagen per Einschreiben bestanden, gehalten, diese so, wie sie aufgesetzt worden sind, zu akzeptieren.

4. Lieferung

Die Ware reist auf Risiko und Gefahr des Käufers, auch falls sie "frei Bestimmung" oder "frei Haus des Käufers" verkauft wird und unsere Haftung endet mit der Auslieferung an den Transportunternehmer, bei dem der Käufer - nach Durchführung der entsprechenden Überprüfungen - eventuelle Beanstandungen geltend machen muss. Das Abladen der Ware von den Transportfahrzeugen geht zu Lasten des Käufers. Die Lieferungen ins Ausland auf dem See- oder Landweg werden auf Grundlage von von Mal zu Mal ausgewählten Bedingungen ausgeführt, die in den von der Internationalen Handelskammer 1953ff. anerkannten "INCOTERMS" angegeben werden.

5. Lieferfristen

Die Frist, die für die Lieferung der Ware vereinbart wird, ist zu Gunsten beider Vertragspartner auszulegen. Vorbehaltlich der Aufnahme besonderer Klauseln ist sie als unverbindlich und nicht wesentlich anzusehen. Bei Änderungen des Vertrages wird die Frist um einen Zeitraum verlängert, der dem ursprünglich vereinbarten entspricht. Bei Fällen von höherer Gewalt wird die Frist für deren gesamte Dauer ausgesetzt. Diese verspätete Lieferung der Ware, die auf dokumentierten, auch nicht ausdrücklich vorgesehenen Ursachen beruht, berechtigt den Käufer nicht zur Auflösung des Vertrages oder zu Entschädigungsforderungen.

6. Bezahlung

Der Ort der Bezahlung wird auf unseren Firmensitz festgelegt, auch im Falle der Ausstellung von Tratten, Bankquittungen oder Wechseln. Bei - auch partieller - Verspätung der Bezahlung unserer Rechnungen über die vereinbarte Fälligkeit hinaus werden mit unmittelbarer Wirkung Säumniszinsen in Höhe des von den Bankinstituten angewendeten Passivzinssatzes fällig. Außerdem berechtigt uns die unterlassene oder verspätete Bezahlung der Rechnungen - aus jedem beliebigem Grund - und unbeachtet aller weiteren Schritte, die Vorauszahlung der verbleibenden Lieferungen zu fordern oder den Vertrag für vorübergehend oder endgültig ausgesetzt zu betrachten und die Ausführung eventueller sonstiger laufender Bestellungen zu annullieren, ohne dass in diesem Fall Schadensforderungen oder sonstige Forderungen geltend gemacht werden können. Vorbehaltlich der Nichtigkeit, der Annullierbarkeit und des Rücktritts vom Vertrag können vom Käufer keine Ausnahmen für die Verspätung oder Unterlassung der Bezahlung vorgebracht werden.

7. Eigentumsvorbehalt

Falls die Bezahlung den vertraglichen Vereinbarungen gemäß - ganz oder teilweise - nach der Lieferung zu erfolgen hat, so bleiben die gelieferten Produkte unser Eigentum bis zur vollständigen Bezahlung des Preises.

8. Garantie

Unsere Garantie ist auf die Materialien 1. Wahl beschränkt, mit einer Toleranz von ca. 5% (fünf Prozent). Bei Materialien 2. und 3. Wahl sowie bei Lagerbeständen, die wie gelegentliche Partien stets als "gesehen" und "gefallen" verkauft werden, ist jede Garantieleistung für Mängel ausgeschlossen. Tonabweichungen können nicht als Mängel geltend gemacht werden. Eventuelle Reklamationen und Beanstandungen müssen vor der Verlegung des Materials und vor Ablauf der gesetzlichen Frist per Einschreiben einzig und allein an unseren Firmensitz gemeldet werden, anderenfalls verfällt der Gewährleistungsanspruch. Die Verlegung des Materials führt zum Verfall des Gewährleistungsanspruches für offensichtliche und versteckte Mängel und führt gemäß § 1490 des ital. Bürgerlichen Gesetzbuches zu einem impliziten Verzicht auf den Garantieleistungsanspruch. In jedem Fall umfasst unsere Garantie ausschließlich die Ersetzung des mangelhaften Materials und alle weiteren Verpflichtungen sind ausgeschlossen. Wir übernehmen keinerlei Haftung für Eignung des Materials für die vom Käufer vorgesehene Verwendungsweise, auch dann nicht, wenn unsererseits Empfehlungen oder Angaben zur Verwendung desselben gemacht werden.

9. Gerichtsstand

Sämtliche Rechtssachen zwischen dem Verkäufer und dem Käufer, die sich auf die Lieferung beziehen, unterliegen der italienischen Rechtsprechung; Gerichtsstand ist Modena.

10. Schiedsklausel

Bei Lieferungen ins Ausland werden sämtliche Rechtssachen, die aus dem Vertrag entstehen, in definitiver Weise auf Grundlage der Schlichtungsbestimmungen der Internationalen Handelskammer von einem oder mehreren Schlichtern entschieden. Unter Beibehaltung der vorausgehenden Allgemeinen Bedingungen ist im wesentlichen das italienische Recht anwendbar.

11. Handelsmarken

Der Händler darf die Namen, Handelsmarken, Logos sowie Domänen, deren ausschließlicher Inhaber und Benutzer Nuova Rival Ceramiche S.r.l. ist, ausschließlich für die Werbung sowie für den Verkauf der Vertragsprodukte verwenden. Sowohl der Name Rival Ceramiche, als auch alle anderen von Nuova Rival Ceramiche S.r.l. verwendeten Namen, Handelsmarken, Logos und Domänen dürfen nicht im Namen, der Geschäftsbezeichnung oder im Geschäftszweck des Händlers erscheinen, auch nicht in Wortkombinationen. Der Händler hinterlegt keine Marken, Namen oder sonstige Kennzeichnungen, die den Handelsnamen und -marken von Nuova Rival Ceramiche S.r.l. auf grafische, phonetische oder sonstige Weise ähnlich sind und er vermeidet sämtliche Verhaltensweisen, die Nuova Rival Ceramiche S.r.l. schädigen könnten.

condizioni generali di vendita

general sales conditions - conditions générales de vente - allgemeine verkaufsbedingungen

condiciones generales de venta - Общие условия продажи

1. Premisa

Las presentes condiciones generales, salvo eventuales modificaciones o derogas acordadas por escrito, reglamentan todos los contratos de venta entre el comprador y Riwal (vendedor). Las variaciones de las condiciones generales de venta, las transacciones y los descuentos, aunque se efectúen por iniciativa de nuestros agentes, nos comprometerán solo después de nuestra eventual confirmación escrita y se limitarán a los contratos a los que hacen referencia.

2. Objeto del suministro

El suministro incluye solamente las prestaciones, los materiales y las cantidades especificadas en nuestra confirmación de pedido o en otras comunicaciones escritas por nosotros. El texto de nuestra confirmación de pedido prevalecerá, en todo caso, sobre el texto diferente de la eventual oferta o del pedido.

3. Confirmación del pedido

En caso de que en nuestra confirmación de pedido existan diferencias en los elementos individuales que la componen respecto a los acuerdos o a los pedidos, el comprador que no haya notificado con carta certificada enviada antes de diez días a partir de la recepción de la confirmación dichas diferencias, deberá aceptarla tal y como ha sido redactada.

4. Entrega

La mercancía, también si se ha vendido "franco llegada", o franco domicilio del comprador, viaja bajo la responsabilidad de éste último y toda responsabilidad nuestra cesa en el momento de la entrega al transportista, frente al cual, el comprador, efectuadas las oportunas verificaciones, deberá presentar eventuales reclamaciones. El coste de la descarga de la mercancía de los medios de transporte corre a cargo del comprador. Los envíos, por mar o por tierra, concernientes a suministros al extranjero, se efectúan en base a las condiciones elegidas cada vez, citadas en los "INCOTERMS", aprobados por la Cámara de Comercio Internacional en 1953 y en los sucesivos.

5. Plazos de entrega

El plazo establecido para la entrega de la mercancía debe considerarse a favor de ambos contrayentes. Salvo la introducción de cláusulas particulares, esto debe considerarse por norma puramente indicativo y no esencial. Cuando se hayan realizado modificaciones en el contrato, el plazo resta prorrogado por un periodo igual al establecido inicialmente. Cualquier situación de fuerza mayor suspende el inicio del plazo durante toda la duración de la misma. El retraso en la entrega de la mercancía, debido a causas documentadas, aunque no estén expresamente previstas, no da ningún derecho al comprador a solicitar la rescisión del contrato, indemnizaciones o resarcimientos.

6. Pagos

El lugar de pago queda fijado en nuestra Sede, también en caso de emisión de libranzas o de letras de cambio, o en caso de emisión de otros efectos.

El retraso, aunque parcial, del pago de nuestras facturas más allá del plazo acordado, dará lugar al inicio inmediato de la aplicación de los intereses de demora en la medida de las tasas pasivas practicadas por los institutos bancarios. Además la ausencia o el retraso del pago de las facturas, por cualquier razón, nos dará derecho, pendientes de cualquier otra iniciativa, a pretender el pago anticipado de los restantes suministros, o a considerar temporalmente suspendido o definitivamente rescindido el contrato y a anular la evasión de otros eventuales pedidos en curso, sin que el comprador pueda presentar reclamaciones de compensaciones, indemnizaciones u otros. Ninguna excepción, salvo la de la nulidad, anulabilidad, y rescisión del contrato puede ser opuesta al comprador, con el fin de retrasar o evitar el pago.

7. Reserva de Propiedad

En caso de que el pago, por acuerdos contractuales, deba ser efectuado, en todo o en parte, después de la entrega, los productos entregados permanecen de nuestra propiedad hasta el pago integral del precio.

8. Garantía

Nuestra garantía está limitada a los materiales de 1ª calidad, con la tolerancia del 5% (cinco por ciento) aproximadamente. Toda garantía por defectos queda expresamente excluida para los materiales de 2ª y 3ª calidad o en stock que, como los lotes ocasionales, se consideran siempre vendidos como "vistos" y "aceptados". Las diferencias de tonalidad no pueden ser denunciadas como defectos del material. Eventuales reclamaciones y quejas deberán notificarse, so pena de caducidad, trámite carta certificada, únicamente en nuestra Sede, antes de la colocación del material y, en todo caso, según la ley. La colocación del material determina la caducidad de la acción por defectos tanto evidentes como ocultos, comportando la renuncia implícita a la garantía según el art. 1490 del código civil italiano. En todo caso nuestra garantía incluye únicamente la sustitución del material defectuoso con exclusión de cualquier ulterior obligación. No asumimos ninguna responsabilidad sobre la idoneidad del material para el uso al que el comprador pretende destinarlo y esto ni siquiera en la hipótesis en la que, por parte nuestra, se den sugerencias o indicaciones sobre la instalación y el propio uso.

9. Foro competente

Para cualquier controversia, en todo caso, relativa al suministro, tanto por parte del vendedor como por parte del comprador, se atribuye competencia, con aplicación de la ley italiana, al Tribunal de Modena.

10. Cláusula arbitral

Para el suministro al extranjero, todas las controversias derivadas eventualmente del contrato, serán resueltas por vía definitiva según el reglamento de conciliación y de arbitraje de la Cámara de Comercio Internacional por uno o más árbitros, de acuerdo con dicho reglamento. Manteniendo las condiciones generales que preceden, el derecho sustancial aplicable será exclusivamente el italiano.

11. Marcas comerciales

El distribuidor debe utilizar los nombres y las marcas comerciales, los logotipos, y los dominios de los que es titular exclusiva y usa Nuova Riwal Ceramiche S.r.l. con el único objetivo de hacer publicidad y vender los productos contractuales. Tanto el nombre Riwal Ceramiche como cualquier otro nombre o marca comercial, logotipo y dominio adoptados por Nuova Riwal Ceramiche S.r.l. no deberán aparecer en la empresa, razón social, denominación social o en el objeto social del distribuidor, tampoco en combinación de palabras. El distribuidor no depositará o hará que se deposite ni usará de ninguna manera marcas, nombres u otras señales distintivas que asemejen gráficamente, fonéticamente o en cualquier otro modo a las marcas y nombres comerciales que pertenecen a Nuova Riwal Ceramiche S.r.l. y se abstendrá de todo comportamiento que pueda, de alguna manera, acarrear un perjuicio a Nuova Riwal Ceramiche S.r.l.

1. Предусловие

Следующие общие условия, за исключением возможных письменно согласованных изменений или отклонений, регулируют все контракты о продаже, заключенные между нами и покупателями. Изменения общих условий продажи, мировые сделки и скидки, даже если они предложены нашими агентами, являются для нас обязывающими только после нашего письменного подтверждения, и в любом случае их действие ограничивается контрактами, к которым они относятся.

2. Предмет поставки

Поставка включает в себя лишь только услуги, материалы и количества, указанные в нашем подтверждении заказа или в других изданных нами письменных документах. В любом случае, текст нашего подтверждения заказа преобладает над отличающимся от него текстом возможного предложения или заказа.

3. Подтверждение заказа

Если отдельные составляющие элементы подтверждения заказа отличаются от договоренностей или от заказов, покупатель должен отказаться от таких отклонений заказным письмом в течение десяти дней после получения подтверждения заказа. В противном случае, он обязан согласиться с редакцией подтверждения заказа.

4. Доставка

Даже если товар был продан на условиях "франко место назначения" или франко место нахождения покупателя, он перевозится под ответственностью последнего, при чем любая наша ответственность прекращается в момент передачи товара грузоперевозчику. Поэтому, после выполнения необходимой проверки, покупатель должен выставлять претензии только грузоперевозчику. Расходы по разгрузке товара с транспортного средства лежат на покупателе. Отгрузка сухопутным или морским путем международных поставок выполняется на основе выбранных в каждом отдельном случае условий, исходя из правил "ИНКОТЕРМС", одобренных международной Торговой палатой в 1953 году и из последующих изданий.

5. Сроки поставки

Срок, согласованный для доставки товара, должен толковаться в пользу обеих договаривающихся сторон. При отсутствии специальных оговорок, как правило, этот срок считается лишь ориентировочным и не существенным. В случае внесения изменений в контракт, срок отодвигается на период, равняющийся ранее согласованному сроку. Каждое форс-мажорное обстоятельство, во время его действия, прекращает отчет срока. Задержка в поставке товара, если она вызвана уважительными причинами, даже не специально предусмотренными, не дает покупателю право требовать расторжения контракта, компенсации или возмещения убытков.

6. Оплата

Место произведения оплаты - это адрес нашей компании, даже в случае выставления тратт или предьявительских тратт, или же выдачи векселей. Задержка, даже частичная, в оплате наших инвойсов сверх согласованного срока вызывает немедленное начисление процентов по просроченной задолженности в размере процентной ставки на заемный капитал, взимаемой банковскими учреждениями. Кроме того, невыплата или задержка в выплате инвойсов (по каким то ни было причинам) дает нам право, помимо всего прочего, требовать досрочную оплату оставшихся поставок, или считать контракт временно или окончательно расторгнутым, невыполнять возможно имеющиеся другие заказы, при чем покупатель не имеет права требовать компенсацию, возмещение убытков или прочие требования. В целях задержки или уклонения от выплаты покупатель не может выставлять никакое возражение, кроме недействительности, оспоримости и расторжения контракта.

7. Право собственности

В случае, если по контрактной договоренности оплата будет полностью или частично производиться после доставки, то поставленный товар остается нашей собственностью вплоть до полной оплаты его цены.

8. Гарантия

Наша гарантия распространяется только на материал первого сорта, с приблизительным допуском в размере 5% (пяти процентов). Следовательно, явно исключается любая гарантия на дефекты материала второго и третьего сорта, а также товарных запасов, которые, так же как и случайные партии, продаются в состоянии, в котором они были "осмотрены и одобрены". Разница в тоне не принимается как дефект материала. Возможные претензии и споры должны сообщаться, под угрозой утраты права на них, заказным письмом, направленным исключительно на наш юридический адрес, перед укладкой материала и, в любом случае, до истечения предусмотренного законом срока. Укладка материала влечет за собой утрату права на требование компенсации по явным или скрытым дефектам, так как представляет собой отказ от гарантии, предусмотренной ст. 1490 ГК. В любом случае, наша гарантия предусматривает лишь только замену признанного дефектным материала с исключением всех остальных обязанностей. Мы не возлагаем на себя никакой ответственности относительно пригодности материала предусмотренному покупателем применению, даже в случае, если мы предоставили рекомендации или указания по установке и применению данного материала.

9. Торговые марки

Дистрибутор обязан использовать названия, торговые марки, логотипы и домены, являющиеся исключительной собственностью компании Nuova Riwal Ceramiche S.r.l. и используемые ею, только в целях рекламы и продажи контрактных изделий. Как название Riwal Ceramiche, так и остальные названия, торговые марки, логотипы и домены, используемые компанией Nuova Riwal Ceramiche S.r.l., не должны присутствовать в фирменном названии, официальном названии, наименовании или в предмете деятельности дистрибутора, даже в словесных сочетаниях. Дистрибутор обязуется не регистрировать и не использовать ни коим образом марки, названия и другие отличительные знаки, графически, фонетически или другим образом напоминающие марки и фирменные названия Nuova Riwal Ceramiche S.r.l., при чем он обязуется также не принимать никакое действие, которое может повредить компании Nuova Riwal Ceramiche S.r.l.

10. Компетентный суд

По любому спору, относящемуся к поставке, как продавец, так и покупатель признают, что компетентным судом является суд г. Модены, и что будет применяться итальянское законодательство.

11. Арбитраж

В случае международных поставок все споры и разногласия, связанные с контрактом, будут окончательно решаться в соответствии с Регламентом примирения и арбитража международной Торговой палаты одним или более судьями с соблюдением данного регламента. Оставляя неизменными приведенные выше общие условия, применяемым правом является лишь только итальянское право.

2СМ

Informazioni tecniche

Technical information

Informations techniques

Technische informationen

Información técnica

Техническая информация

LASTRE A SPESSORE MAGGIORATO PER PAVIMENTAZIONI ESTERNE.

2CM è la soluzione più evoluta per pavimentare aree esterne pedonali come giardini, balconi, camminamenti, pavimenti carrabili, ecc.

Le lastre 2CM sono ingelive, resistenti agli attacchi chimici, ai fattori atmosferici, agli agenti inquinanti; sono inassorbenti quindi di facile pulizia e manutenzione e grazie alla loro conformazione hanno una elevata resistenza alla flessione e agli urti e possono sopportare carichi statici elevati (dissuasori, panchine, fioriere, arredo urbano in genere).

Mediante l'utilizzo di supporti plastici (piedini) di varie misure ed altezze, le lastre vengono posate a secco su caldane grezze, guaine bituminose, pavimentazioni esistenti, creando delle intercapedini tecniche di altezza variabile che consentono sia il passaggio di reti impiantistiche che un regolare deflusso delle acque meteoriche.

Questo sistema consente di ottenere diversi vantaggi tecnici ed economici:

- Una riduzione considerevole dei tempi di posa.
- Un ottimo isolamento acustico e termico degli eventuali locali sottostanti grazie alla intercapedine d'aria che si forma tra la pavimentazione ed il sottofondo.
- Il riutilizzo totale del materiale in caso di interventi di ispezione o riparazione del sottofondo o degli impianti.

*Per maggiori informazioni su 2CM
contattare i nostri uffici commerciali.*

THICKER SLABS FOR OUTDOOR FLOORS.

2CM is an extremely cutting-edge solution for tiling outdoor pedestrian areas such as gardens, balconies, walkways, carriageable floors, etc.

2CM slabs are frostproof, and resistant to chemical attacks, atmospheric factors and polluting agents; they are non-absorbent and therefore easy to clean and maintain, and thanks to their conformation, they have high bending strength and shock resistance and can bear high static loads (bollards, benches, plant containers, and urban furniture in general).

With the use of plastic supports (feet) of various sizes and heights, the slabs are dry laid on rough concrete slabs, bituminous coatings or existing floors, creating technical cavities of variable height that allow both the passage of systems installations and the regular draining away of rainwater.

This system enables several technical and financial advantages to be obtained:

- A considerable reduction in laying times.
- Excellent acoustic and thermal insulation for any premises below, thanks to the air cavity that forms between floor and underlayer.
- The total re-use of the material in the case of inspection or repair interventions on the underlayer or the installations.

*For more information about 2CM,
please contact our sales offices.*

DALLES À ÉPAISSEUR MAJORÉE POUR CARRELAGE SOLS EXTÉRIEURS.

2CM est la solution la plus évoluée pour le revêtement d'espaces extérieurs tels que les passages sous jardins, balcons, les parcours dallés, carreaux passage, etc.

Les dalles 2CM sont ingélives, résistantes aux attaques chimiques, aux facteurs atmosphériques et aux agents polluants ; elles sont étanches, donc faciles à nettoyer et à entretenir, et grâce à leur conformation elles sont hautement résistantes à la flexion et aux chocs et peuvent supporter des charges statiques élevées (bornes escamotables, bancs, jardinières, aménagement urbain en général).

En utilisant des supports plastiques (pieds) de dimensions et hauteurs différentes, les dalles sont posées à sec sur des supports bruts, des gaines bitumineuses, des dallages existant déjà, en créant ainsi des interstices techniques de hauteur variable qui permettent tout aussi bien de faire passer des réseaux d'équipement qu'un écoulement régulier des eaux de pluie.

Ce système permet d'obtenir plusieurs avantages techniques et économiques :

- Une réduction considérable des temps de pose.
- Une excellente isolation acoustique et thermique des pièces situées éventuellement au-dessous, et ce grâce à l'interstice d'air qui se forme entre le sol et la sous-couche.
- La réutilisation totale du matériau en cas d'inspection ou de réparation de la sous-couche ou des équipements.

*Pour de plus amples informations concernant le 2CM
prière de contacter nos services commerciaux.*

PLATTEN MIT HÖHERER STÄRKE FÜR BODENVERKLEIDUNGEN IN AUSSENRAUMEN.

2CM ist die fortschrittlichste Lösung für die Verlegung von Fußböden in externen Fußgängerbereichen wie Garten, Balkon, Gehwege, Befahrbarbelag, usw.

Die Platten 2CM sind frostfest und gegen Chemikalien, Witterungseinflüsse und Schmutzmittel beständig. Sie sind nicht aufnahmefähig und daher leicht zu reinigen und instand zu halten, besitzen dank ihrer Form eine gehobene Biege- und Stoßfestigkeit und können hohe statische Lasten tragen (Absperrpoller, Bänke, Blumenkästen und Stadtmobiliar im Allgemeinen).

Die Platten werden unter Verwendung von Kunststoffträgern (Füßchen) in verschiedenen Größen und Höhen trocken auf groben Estrichen, Bitumenmäntel oder alten Bodenbelägen verlegt und bilden technische Zwischenschichten in veränderlichen Höhen, die sowohl die Durchführung von Anlagennetzen als auch das ordnungsgemäße Abfließen von Regenwasser ermöglichen.

Dieses System bietet verschiedene technische und wirtschaftliche Vorteile:

- Beachtlich kürzere Verlegungszeiten.
- Eine ausgezeichnete Schall- und Wärmeisolierung der eventuell darunter befindlichen Räume, dank der Luftzwischen-schicht, die sich zwischen dem Bodenbelag und dem Untergrund bildet.
- Eine volle Wiederverwendbarkeit des Materials im Falle von Inspektionen oder Reparaturen des Untergrundes oder der Anlagen.

*Unsere Vertriebsabteilung liefert gerne
nähere Infos über 2CM.*



posa sopraelevata

raised laying - pose surelevée - erhöhtes verlegen

2CM garantisce estetica e performance di primo livello anche per la creazione di pavimenti sopraelevati. In esterno tale soluzione permette di creare, tra il piano di sottofondo e quello di calpestio costituito dalle lastre ceramiche, uno spazio SEMPRE ISPEZIONABILE per l'allocazione di impianti e tubazioni di ogni genere.

2CM guarantees top-class beauty and performance also when creating outdoor raised floors. With this solution, a space can be made, between the underlayer and the floor for foot traffic comprising ceramic slabs, which CAN ALWAYS BE INSPECTED for the fitting of all kinds of installations and piping.

2CM garantit esthétique et performances exceptionnelles y compris pour la réalisation de dallages surélevés. A l'extérieur, cette solution permet de créer, entre la sous-couche et le plan de passage formé par les dalles céramiques, un espace qui RESTE CONTROLABLE pour la mise en place d'installations et de conduites en tout genre.

2CM garantiert eine schöne Optik und Performance erster Klasse auch für die Bildung erhöhter Fußböden. Im Außenbereich kann durch diese Lösung zwischen der Unterputz- und Trittläche, welche aus Keramikplatten besteht, ein Raum geschaffen werden, in dem Anlagen und Rohrleitungen jeglicher Art untergebracht werden können UND DER FÜR INSPEKTIONEN STETS ZUGÄNLICH ist.



Installazione in prossimità di muretti, angoli e spigoli

verlegung in der Nähe von Wänden, aussenecken und innenecken
 pose en oeuvre a proximité des murs, d'angles rentrants ou sortants
 installation close to walls, corners or edges

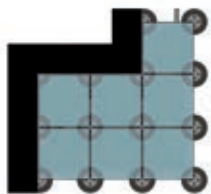

É necessario allontanare i supporti dal muro tagliando due o tutti e quattro i distanziatori.

The supports must be furthered from walls, corners and edges by cutting two or even all the spacers of their top.

A proximité des murs, d'angles rentrants et d'angles sortants, il faut éloigner les supports en coupant deux ou quatre pièces intercalaires.

In der Nähe von Wänden, Außenecken und Innenecken müssen die Stelzlager mit Abstand von der Wand platziert werden oder 2 bzw. 4 Abstandhalter eingeschnitten werden.

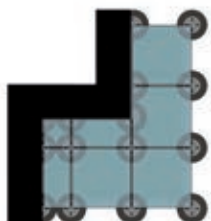

Talvolta è necessario tagliare anche la base dei supporti in caso di interferenza con la base dei supporti adiacenti.

The base of the supports must also be cut in case it obstructs the base of adjacent supports.

En cas d'interférence avec la base des supports adjacents il sera nécessaire de couper aussi la base des supports.

Unter Umständen ist es auch notwendig die Basis der Stelzlager anzupassen, wenn man diese sehr eng beieinander positionieren muß.

posa a secco

dry laying - pose a sec - trockenverlegen

2CM

Le lastre 2CM sono posabili a secco dando vita a PERCORSI e CAMMINAMENTI PEDONALI SU SOTTOFONDI IN ERBA, GHIAIA E SABBIA. Il sistema di posa a secco è immediatamente calpestabile, pratico ed ecologico, in quanto si evita la creazione del tradizionale massetto armato e si esclude totalmente l'impiego di collanti. Il nuovo sistema ceramico di Saime è applicabile in tutti gli ambienti esterni come spiagge, cortili, giardini e terrazzi, grazie alle prestazioni tecniche e alla valenza estetica del gres porcellanato.

2CM slabs can be dry-laid, in order to make PEDESTRIAN PATHS AND WALKWAYS ON GRASS, GRAVEL AND SAND UNDERLAYERS. The dry-laying system can be walked over immediately and is practical and eco-friendly, since it avoids creating the traditional reinforced concrete floor and completely avoids the use of adhesives. This new ceramic system from Saime can be applied in all outdoor surroundings such as shores, courtyards, gardens and terraces, exploiting the technical features and high-quality appearance of porcelain stoneware.

Les dalles 2CM se posent à sec, pour créer des PARCOURS ET PASSAGES PIETONNIERS SUR SOUS-COUCHE D'HERBE, GRAVIER ET SABLE. Le système de pose à sec permet une fréquentation immédiate, il est pratique et écologique car il évite la réalisation de la traditionnelle chape armée ainsi que toute utilisation de colle. Le nouveau système céramique de Saime trouve son application en tout lieu extérieur tels que plages, cours, jardins et terrasses grâce à ses propriétés techniques et à l'intérêt esthétique du grès cérame.

Die Platten 2CM sind trocken verlegbar und bilden STRECKEN SOWIE FUSSGÄNGERWEGE AUF UNTERPUTZ AUS GRAS, KIES UND SAND. Das Trockenverlegesystem ist sofort betretbar, praktisch und umweltfreundlich, da die Erzeugung des traditionellen armierten Unterbetonblocks vermieden wird und man keinerlei Kleber einzusetzen braucht. Dank der technischen Leistungen und der Optik des Steinzeugs ist das neue Keramiksystem von Saime in allen Außenräumen wie Stränden, Höfen, Gärten und Terrassen anwendbar.



Ghiaietto - Gravel - Gravier - Kies



Sabbia - Sand - Sable - Sand

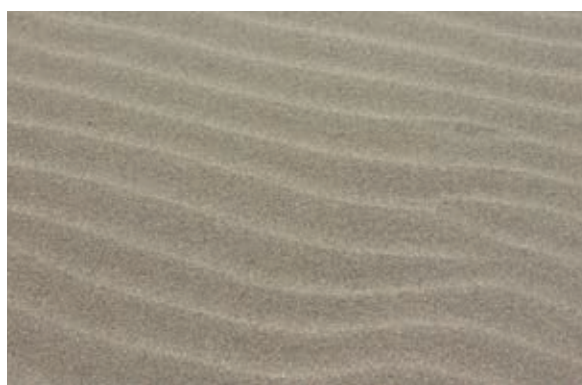

Erba - Gras - Herbe - Grass



technical section

THINKGREEN

Saime Ceramiche pone al centro dell'azione una particolare sensibilità all'ecosostenibilità dei propri processi industriali. Il costante investimento di capitali e professionalità pone l'azienda all'avanguardia nello sviluppo di sistemi produttivi a massima efficienza e minimo impatto, in grado di garantire un pieno rispetto dell'ambiente e l'eccellenza di una gamma di prodotti totalmente ecocompatibili.

Saime Ceramiche places great emphasis on having a special sensitivity to eco-sustainability in its industrial processes. Constant investments of capital and professional skills places the company at the leading edge in developing maximum efficiency, minimum impact production systems, that will guarantee full respect for the environment, as well as excellence in the totally eco-compatible product range.

Saime Ceramiche accorde un intérêt tout particulier à l'éco-durabilité de ses processus industriels. Par ses investissements constants en matière de capitaux et de professionnalisme, l'entreprise est à l'avant-garde dans le développement de systèmes de production qui allient efficacité maximale et impact minimal, assurant un respect absolu de l'environnement et l'excellence d'une gamme de produits totalement éco-compatibles.

Saime Ceramiche legt großen Wert auf die ökologische Nachhaltigkeit seiner Industrieprozesse. Durch die konstanten Investitionen in Kapital und Fachwissen steht das Unternehmen an vorderster Stelle bei der Entwicklung von Produktionssystemen mit maximaler Effizienz und minimaler Umweltbelastung; dadurch wird der Schutz der Umwelt und die Qualität von vollumfänglich nachhaltigen Produkten garantiert.

Saime Ceramiche pone en el centro de la acción una particular sensibilidad por la ecosostenibilidad de sus procesos industriales. La constante inversión de capitales y en profesionalidad coloca a la empresa en la vanguardia del desarrollo de sistemas productivos con máxima eficiencia y mínimo impacto, capaces de garantizar un pleno respeto del medio ambiente y la excelencia de una gama de productos totalmente ecocompatibles.

В работе Saime Ceramiche особое внимание уделяется экологической рациональности собственных промышленных процессов. Благодаря постоянным инвестициям капиталов и профессиональных навыков компания занимает передовые позиции в развитии максимально эффективных, минимально загрязняющих производственных систем, гарантирующих полную охрану природы и высокие характеристики совершенно экологичной продукции.



Saime Ceramiche definisce i propri sistemi produttivi nel pieno rispetto dei rigidi requisiti IPPC (Integrated Pollution Prevention and Control) in materia di riduzione delle emissioni inquinanti, efficienza energetica e ottimizzazione produttiva. Tutti i prodotti Saime Ceramiche sono realizzati attraverso processi e tecnologie che ne garantiscono sempre massima qualità e sostenibilità ambientale.

Saime Ceramiche defines its production systems in full compliance with the stringent IPPC (Integrated Pollution Prevention and Control) requirements with regard to reducing polluting emissions, energy efficiency and optimizing production. All Saime Ceramiche products are created with processes and technologies that always guarantee maximum quality and environmental sustainability.

Les systèmes de production Saime Ceramiche respectent pleinement les strictes exigences de la directive IPPC (Integrated Pollution Prevention and Control, prévention et réduction intégrées de la pollution) en matière d'émissions polluantes, d'efficacité énergétique et d'optimisation de la production. Tous les produits Saime Ceramiche sont réalisés au moyen de processus et de technologies assurant toujours une qualité maximale et la durabilité environnementale.

Die Produktionssysteme von Saime Ceramiche werden so projektiert, dass sie den strengen Anforderungen der IPPC (Integrated Pollution Prevention and Control), was die Reduktion der Schadstoffe, die Energieeffizienz und die Produktionsoptimierung betrifft, voll entsprechen. Alle Produkte von Saime Ceramiche werden mit Verfahren und Technologien realisiert, die stets höchste Qualität und Umweltverträglichkeit garantieren.

Saime Ceramiche define sus sistemas productivos respetando los rígidos requisitos IPPC (Integrated Pollution Prevention and Control) en materia de reducción de emisiones contaminantes, eficiencia energética y optimización productiva. Todos los productos Saime Ceramiche están realizados a través de procesos y tecnologías que garantizan siempre la máxima calidad y sostenibilidad medioambiental de los mismos.

Saime Ceramiche разрабатывает свои производственные системы с полным соблюдением жестких требований IPPC (Integrated Pollution Prevention and Control, комплексное предотвращение и контроль загрязнений) в плане снижения загрязняющих выбросов, энергоэффективности и оптимизации производства. Вся продукция Saime Ceramiche выпускается с применением процессов и технологий, обеспечивающих наивысшее качество и экологическую рациональность.

ANIMAVERDE

ANIMA VERDE
SENSIBILITÉ ENVIRONNEMENTALE
NACH HALTIGKEIT
ALMA VERDE
ЗЕЛЕНАЯ ДУША



MASSIMA SICUREZZA

Il ciclo di produzione è severamente controllato attraverso verifiche periodiche. Macchine, impianti e lavoratori sono dotati dei più moderni sistemi di sicurezza.

MAXIMUM SAFETY

The production cycle is strictly controlled by means of periodic checks. Machines, equipment and workers are equipped with very up-to-date safety systems.

SÉCURITÉ MAXIMALE

Grâce à des contrôles réguliers, un suivi scrupuleux du cycle de production est assuré. Machines, installations et travailleurs sont équipés des dispositifs de sécurité les plus modernes.

MAXIMALE SICHERHEIT

Der Produktionszyklus wird anhand von periodisch durchgeführten Überprüfungen strengstens kontrolliert. Maschinen, Anlagen und Mitarbeiter sind mit modernsten Sicherheitssystemen ausgestattet.

MÁXIMA SEGURIDAD

El ciclo de producción está severamente controlado a través de verificaciones periódicas. Las máquinas, las instalaciones y los trabajadores están equipados de los sistemas de seguridad más modernos.

НАИВЫСШАЯ БЕЗОПАСНОСТЬ

Производственный цикл постоянно проверяется и подвергается периодическому контролю. Самые современные системы безопасности применяются для охраны оборудования, систем и работников.



EFFICIENZA ENERGETICA

Produzione autonoma di energia attraverso un innovativo impianto di cogenerazione che consente un'elevata efficienza energetica.

ENERGY EFFICIENCY

Independent energy production by means of an innovative cogeneration plant that allows high energy efficiency.

EFFICACITÉ ÉNERGÉTIQUE

Une installation de cogénération innovante à haute efficacité énergétique assure l'autonomie en matière de production d'énergie.

ENERGIEEFFIZIENZ

Autonome Energieproduktion anhand einer innovativen Wärme-Kraft-Kopplungsanlage, die eine hohe Energieeffizienz zusichert.

EFICIENCIA ENERGÉTICA

Producción autónoma de energía a través de una innovadora planta de cogeneración que permite obtener una elevada eficiencia energética.

ЭНЕРГОЭФФЕКТИВНОСТЬ

Автономное производство электроэнергии осуществляется при помощи инновационной когенерационной установки, обеспечивающей высокую энергетическую эффективность.



RICICLO TOTALE

Tutti gli scarti di processo, liquidi, solidi cotti e crudi, sono integralmente recuperati all'interno del ciclo produttivo.

TOTAL RECYCLING

All process waste, liquids, and fired and raw solids are recovered entirely within the production cycle.

RECYCLAGE TOTAL

Tous les rebuts de production, liquides, solides cuits et crus, sont entièrement réintroduits dans le cycle de production.

TOTALRECYCLING

Alle Prozessabfälle, Flüssigkeiten, gebranntes und rohes Festmaterial werden innerhalb des Produktionszyklus recycelt.

RECICLAJE TOTAL

Todos los desechos del proceso, líquidos, sólidos cocidos y crudos, se pueden recuperar integralmente en el ciclo de producción.

ПОЛНАЯ ПЕРЕРАБОТКА

Все жидкие и твердые, сырые или обожженные отходы полностью перерабатываются в рамках производственного процесса.



NO SOSTANZE TOSSICHE

Totale assenza di sostanze tossiche e/o nocive all'interno dei processi di lavorazione e in ogni fase del ciclo di produzione.

NO TOXIC SUBSTANCES

Complete absence of toxic and/or harmful substances in the working processes and in each phase of the production cycle.

PAS DE SUBSTANCES TOXIQUES

Absence totale de substances toxiques et/ou nocives dans les processus de traitement et dans chaque phase du cycle de production.

KEINE GIFTIGEN STOFFE

Absolut frei von giftigen und/oder schädlichen Stoffen innerhalb der Bearbeitungsprozesse und in jeder Phase des Produktionszyklus.

NINGUNA SUSTANCIA TÓXICA

Total ausencia de sustancias tóxicas y/o nocivas en los procesos de elaboración y en las fases del ciclo de producción.

ОТКАЗ ОТ ТОКСИЧНЫХ ВЕЩЕСТВ

Токсичные и/или вредные вещества полностью отсутствуют в процессах обработки и на любом этапе производственного цикла.



ZERO EMISSIONI

Le emissioni gassose sono integralmente depurate attraverso le più avanzate tecnologie di filtraggio.

ZERO EMISSIONS

Gaseous emissions are completely purified using cutting-edge filtering technologies.

ZÉRO ÉMISSION

Les émissions gazeuses sont entièrement épurées à l'aide des technologies de filtration les plus avancées.

NULLEMISSIONEN

Die Abgasemissionen werden über die fortschrittlichsten Filtertechnologien gereinigt.

CERO EMISIONES

Las emisiones gaseosas se depuran completamente a través de las tecnologías de filtración más modernas.

НУЛЕВЫЕ ВЫБРОСЫ

Газовые выбросы полностью очищаются с применением самых передовых технологий фильтрации.

La certificazione LEED (Leadership in Energy and Environmental Design) è un sistema di certificazione sostenibilità aziendale ed energetica degli edifici applicato in oltre 140 paesi nel mondo. Elaborata nel 1993 dalla U.S. Green Building Council (USGBC) ha come scopo base la promozione e lo sviluppo di un approccio globale alla sostenibilità ambientale, sociale ed economica degli edifici, dalla fase di progettazione fino alla gestione quotidiana. Il metodo di certificazione prevede l'attribuzione di un punteggio all'edificio riconosciuto sulla base della verificata conformità dello stesso a diversi prerequisiti e crediti Leed.

Il gres porcellanato di Saime Ceramiche è un materiale Leed compliant, ovvero soddisfa i requisiti definiti dalla USGBC per i materiali e le risorse in termini di percentuale di materiale riciclato, effetti isolanti, basse emissioni inquinanti e proprietà innovative e di design. Ciò significa che l'impiego dei materiali Saime Ceramiche per pavimenti o rivestimenti consente l'assegnazione di un punteggio che concorrerà all'attribuzione della certificazione LEED.

LEED (Leadership in Energy and Environmental Design) certification is a system for certifying company and energy sustainability of buildings, and is applied in over 140 countries in the world. It was devised in 1993 by the U.S. Green Building Council (USGBC) and its basic aim is to promote and develop a global approach to environmental, social and economic sustainability of buildings, from the design phase right down to their daily management. This method of certification provides for assigning points to the building, worked out on the basis of its verified compliance with various Leed requirements and credits

Saime Ceramiche porcelain stoneware are Leed-compliant materials: that is, they meet the requirements defined by the USGBC for materials and resources in terms of percentage of recycled material, insulating effects, low polluting emissions and innovative and design properties. This means that the use of Saime Ceramiche materials for floors or wall tiling allows points to be assigned, that will contribute to giving LEED certification.

La certification LEED (Leadership in Energy and Environmental Design) est un système de certification de la durabilité des bâtiments reconnu dans plus de 140 pays, appliqué à l'entreprise et à l'énergie. Élaborée en 1993 par le U.S. Green Building Council (USGBC), son but fondamental est de promouvoir et développer une approche globale de la durabilité environnementale, sociale et économique des bâtiments, de la phase de conception à la gestion quotidienne. La méthode de certification prévoit l'attribution de points au bâtiment après vérification de sa conformité par rapport à différents critères et crédits LEED.

Le grès cérame de Saime Ceramiche est un matériau conforme au système LEED, c'est-à-dire qu'il respecte pleinement les critères définis par le USGBC pour les matériaux et les ressources, relatifs au pourcentage de matériaux recyclés, aux effets isolants, aux basses émissions polluantes, aux propriétés innovantes et au design. L'utilisation sur sols ou revêtements des matériaux Saime Ceramiche donne ainsi droit à l'attribution de points qui contribueront à l'obtention de la certification LEED.

Die Zertifizierung LEED (Leadership in Energy and Environmental Design) ist ein System für die Unternehmens- und Energienachhaltigkeit von Gebäuden, das in mehr als 140 Ländern der Welt angewandt wird. 1993 vom U.S. Green Building Council (USGBC) erarbeitet, hat sie als Hauptziel die Förderung und Entwicklung eines globalen Ansatzes mit Bezug auf die umweltbezogene, soziale und wirtschaftliche Nachhaltigkeit der Gebäude, von der Projektphase bis zur täglichen Verwaltung. Die Zertifizierungsmethodik sieht eine Punkteverteilung an diejenigen Gebäude vor, die aufgrund von deren überprüfter Konformität den verschiedenen Anforderungen und Leed-Krediten gegenüber anerkannt wurden.

Das Steinzeug von Saime Ceramiche ist ein Leed-konformes Material, das heißt, es erfüllt die von der USGBC für die Materialien und Ressourcen festgelegten Anforderungen im Hinblick auf die Prozentzahl der recycelten Materialien, die Isolierung, die niedrige Schadstoffemission und die innovativen und designbezogenen Eigenschaften. Daraus folgt, dass die Verwendung von Saime Ceramiche-Produkten für Fußböden oder Wandverkleidungen die Zuordnung einer Punktzahl erlaubt, die zur Vergabe der LEED-Zertifizierung beiträgt.

La certificación LEED (Leadership in Energy and Environmental Design) es un sistema de certificación de la sostenibilidad empresarial y energética de los edificios aplicado en más de 140 países del mundo. Creado en 1993 por el U.S. Green Building Council (USGBC), tiene como objetivo fundamental promover y desarrollar un enfoque global de la sostenibilidad medioambiental, social y económica de los edificios, desde la fase de diseño hasta la gestión diaria. El método de certificación prevé la atribución de puntos al edificio reconocido sobre la base de la verificación de conformidad del mismo a diferentes prerequisitos y créditos Leed.

El grés porcelánico de Saime Ceramiche es un material conforme a Leed, es decir, satisface los requisitos definidos por el USGBC para los materiales y los recursos, en términos de porcentaje de material reciclado, efectos aislantes, bajas emisiones contaminantes y propiedades innovadoras y de diseño. Esto significa que el empleo de los materiales Saime Ceramiche para los pavimentos o revestimientos permite asignar una puntuación útil para la atribución de la certificación LEED.

Сертификат LEED (Leadership in Energy and Environmental Design) - это система сертификации корпоративной и энергетической рациональности зданий, которая используется в более, чем 140 странах мира. Она была разработана в 1993 году организацией U.S. Green Building Council (USGBC) и направлена на поощрение и развитие общего подхода к экологической, социальной и экономической рациональности зданий с момента их проектирования до ежедневной эксплуатации. Метод сертификации предусматривает присвоение зданию баллов, основываясь на подтвержденном соответствии объекта разным установленным требованиям и кредитам Leed.

Керамогранит компании Saime Ceramiche является материалом "Leed compliant", то есть, удовлетворяющим требованиям USGBC к материалам и ресурсам в плане процентного содержания переработанного материала, изоляционного эффекта, низкого выделения загрязняющих веществ, инновационных качеств и дизайна. Это значит, что использование материалов Saime Ceramiche для настила полов или облицовки стен позволяет получать баллы, способствующие выдаче сертификата LEED.

SCHEDA PUNTEGGIO

PRODOTTI SAIME CERAMICHE:
CONTRIBUTI ALL'OTTENIMENTO DEL PUNTEGGIO:

Contenuto di Materiale Riciclato (Credito MR 4.1): 2 PUNTI LEED

Oltre il 25% del materiale che costituisce i nostri prodotti contiene materiali crudi e cotti di riciclo (materiale pre-consumo)

Ottimizzazione della Performance Energetica (Credito EA 1): I prodotti Saime Ceramiche concorrono ad accumulare crediti da 1 a 10 PUNTI LEED

Le piastrelle ceramiche essendo materiali a bassa conducibilità termica e soggette a bassissimi sbalzi termici, sono dotate di potere isolante e contribuiscono al risparmio energetico. I nostri prodotti sono particolarmente indicati per rivestimenti di facciate, ventilate e non, e per sistemi di riscaldamento a pavimento

Contenuto di Composti organici volatili VOC (Credito EQ 4.3): 1 PUNTO LEED

Le piastrelle ceramiche, per la loro conformazione, sono a bassissima emissione di sostanze organiche volatili e pertanto rispettano la categoria di credito EQ 4.3 per la qualità ambientale interna.

POINTS SHEET

SAIME CERAMICHE PRODUCTS:
CONTRIBUTIONS TO OBTAINING POINTS:

Content of Recycled Material (Credit MR 4.1): 2 LEED POINTS

Over 25% of the material comprising our products contains recycled raw and fired materials (pre-consumer waste).

Optimization of Energy Performance (Credit EA 1): Saime Ceramiche products contribute to accumulating credits from 1 to 10 LEED POINTS

Ceramic tiles, being low thermal conductivity materials and subject to very low thermal excursions, have insulating properties and contribute to saving energy. Our products are particularly recommended for tiling facades, both ventilated and otherwise, and for underfloor heating systems.

VOC - Volatile organic compounds - content (Credit EQ 4.3): 1 LEED POINT

Ceramic tiles, because of their conformation, have very low emissions of volatile organic substances and therefore comply with credit category EQ 4.3 for indoor environmental quality.

FICHE DE POINTS

PRODUITS SAIME CERAMICHE:
CONTRIBUTIONS À L'OBTENTION DE POINTS:

Contenu recyclé (Crédit MR 4.1): 2 POINTS LEED

Plus de 25 % des matériaux entrant dans la composition de nos produits contient des matériaux recyclés crus et cuits (matériaux pré-consommation).

Optimisation de la performance énergétique (Crédit EA 1): les produits Saime Ceramiche peuvent cumuler de 1 à 10 POINTS LEED

Les carreaux en céramique, un matériau à basse conductibilité thermique sujet à de très faibles écarts thermiques, présentent des propriétés isolantes et contribuent à économiser les ressources énergétiques. Nos produits sont particulièrement indiqués en revêtement de paroi ventilée ou non, ainsi que pour les systèmes de chauffage au sol.

Contenu en COV (composés organique volatils) (Crédit EQ 4.3): 1 POINT LEED

De par leur conformation, les carreaux en céramique présentent de très faibles émissions de composés organiques volatils. Ils respectent à ce titre les exigences de la catégorie EQ 4.3 pour la qualité des environnements intérieurs.

FICHA DE PUNTUACIÓN

PRODUCTOS SAIME CERAMICHE:
CONTRIBUCIONES PARA OBTENER LA PUNTUACIÓN:

Contenido de Material Reciclado (Crédito MR 4.1): 2 PUNTOS LEED

Más del 25% del material que constituye nuestros productos contiene materiales crudos y cocidos provenientes del reciclaje (material pre-consumo).

Optimización del Rendimiento Energético (Crédito ES 1) Los productos Saime Ceramiche contribuyen a acumular créditos de 1 a 10 PUNTOS LEED

Las baldosas cerámicas, siendo materiales de baja conductibilidad térmica y estando sujetas a muy bajos cambios repentinos de temperatura, tienen un poder aislante y contribuyen al ahorro energético. Nuestros productos están particularmente indicados para revestimientos de fachadas, ventiladas y no ventiladas, y para sistemas de calefacción radiante a través del pavimento.

Contenido de compuestos orgánicos volátiles VOC (Crédito EQ 4.3): 1 PUNTO LEED

Las baldosas cerámicas, por su conformación, tienen una emisión muy baja de sustancias orgánicas volátiles y, por lo tanto, respetan la categoría de crédito EQ 4.3 para la calidad medioambiental interna.

PUNKTEVERTEILUNG

PRODUKTE SAIME CERAMICHE:
BEITRAG ZUR VERGABE VON PUNKTEN:

Gehalt von recyceltem Material (Kredit MR 4.1): 2 LEED-PUNKTE

Mehr als 25% des Materials, aus denen unsere Produkte bestehen, enthält gebranntes oder rohes Recyclingmaterial (Pre-consumer Material)

Optimierung der Energieleistung (Kredit EA 1): Die Produkte Saime Ceramiche tragen zur Sammlung von Krediten von 1 bis 10 LEED-PUNKTEN bei

Als Materialien mit geringer Wärmeleitfähigkeit und großer Temperaturwechselbeständigkeit sind Keramikfliesen mit Wärmedämmvermögen ausgestattet und tragen zur Energieersparnis bei. Unsere Produkte sind besonders geeignet für Fassadenverkleidungen mit oder ohne Hinterlüftung und für Fussboden-Heizsysteme

Gehalt von Flüchtigen Organischen Verbindungen VOC (Kredit EQ 4.3): 1 LEED-PUNKT

Durch ihre Zusammensetzung haben Keramikfliesen sehr geringe Emissionen von flüchtigen organischen Verbindungen und entsprechen daher der Kreditkategorie EQ 4.3 für die interne Umweltqualität.

ПРАВИЛА ПОЛУЧЕНИЯ БАЛЛОВ

ПРОДУКЦИЯ SAIME CERAMICHE:
ВКЛАД ДЛЯ ПОЛУЧЕНИЯ БАЛЛОВ:

Содержание повторно использованного материала (Кредит MR 4.1): 2 БАЛЛА LEED

Более 25% материала, из которого состоит наша продукция, содержит сырые и обожженные переработанные материалы (пред-потребительский материал)

Оптимизация энергетических характеристик (Кредит EA 1): продукция Saime Ceramiche позволяет получать кредиты в размере от 1 до 10 БАЛЛОВ LEED

Керамическая плитка является материалом с низкой теплопроводностью, подвергается очень низким тепловым перепадам, обладает изоляционной способностью и позволяет экономить энергию. Наша продукция особенно рекомендована для облицовки вентилируемых или обычных фасадов и для напольных отопительных систем.

Содержание летучих органических компонентов VOC (кредит EQ 4.3): 1 БАЛЛ LEED

Ввиду своей конструкции керамическая плитка выделяет очень низкое количество летучих органических компонентов, поэтому она входит в категорию кредита EQ 4.3 за качество внутренней среды.

schemi di posa

laying solutions - schemas de pose - verlegungbeispiele - Композиционные решения

1

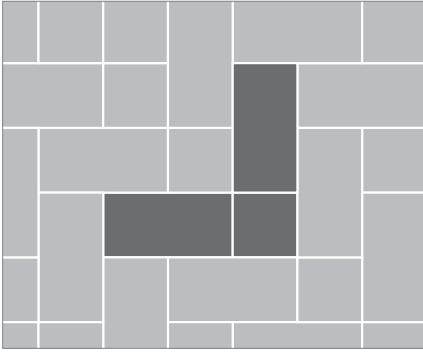

29,7x29,7 RETT. = 20%
29,7x59,5 RETT. = 80%

2

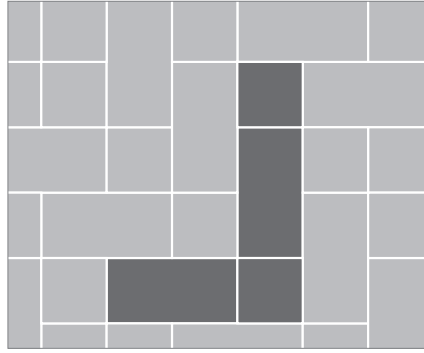

29,7x29,7 RETT. = 33,3%
29,7x59,5 RETT. = 66,7%

3

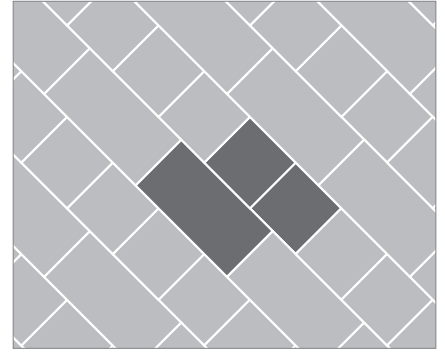

29,7x29,7 RETT. = 50%
29,7x59,5 RETT. = 50%

4

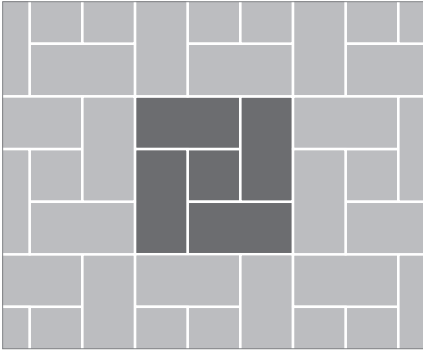

20x20 = 11,1%
20x40 = 88,9%

5

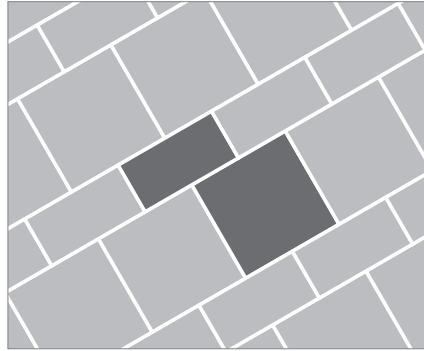

15x30 = 33,3% 16,5x33,3 = 33,3%
30x30 = 66,7% 33,3x33,3 = 66,7%

6

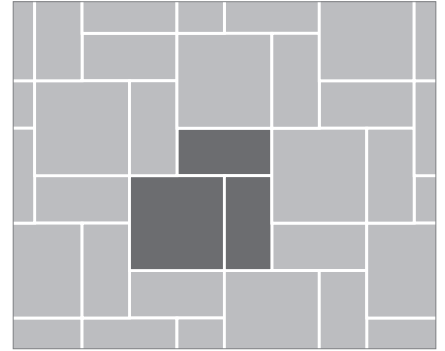

15x30 = 50% 16,5x33,3 = 50%
30x30 = 50% 33,3x33,3 = 50%

7

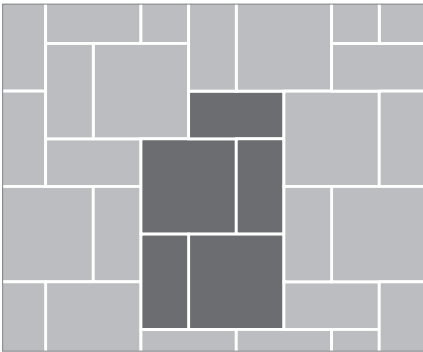

15x30 = 42,5% 16,5x33,3 = 42,5%
30x30 = 57,7% 33,3x33,3 = 57,5%

8

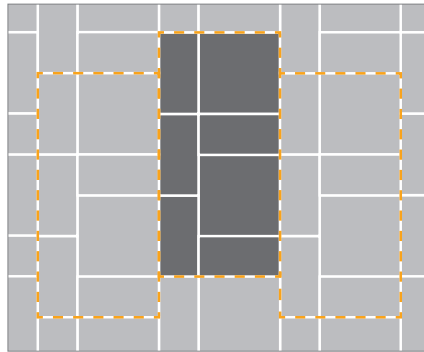

15x30 = 56%
30x30 = 44%

9

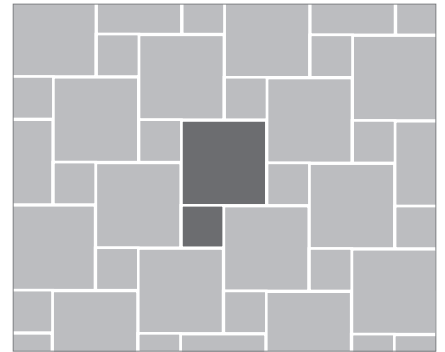

15x15 = 19,4% 16,5x16,5 = 19,4%
30x30 = 80,6% 33,3x33,3 = 80,6%

10



30x60 = 66,7%
15x60 = 33,3%

11



22,5x90 = 60%
15x90 = 40%

12

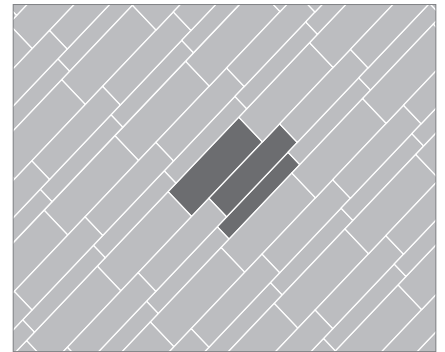

19,5x59,5 RETT. = 44,5%
14,8x59,5 RETT. = 33,3%
9,8x59,5 RETT. = 22,2%

13

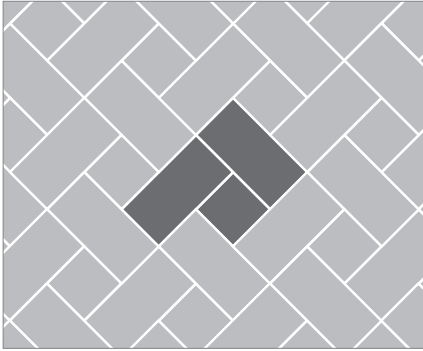

20x20 = 20% 16,5x16,5 = 20%
20x40 = 80% 16,5x33,3 = 80%

14

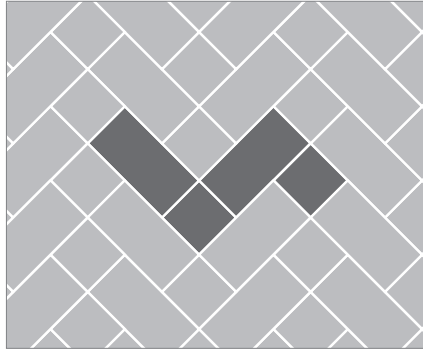

20x20 = 33,30% 16,5x16,5 = 33,3%
20x40 = 66,70% 16,5x33,3 = 66,7%

15

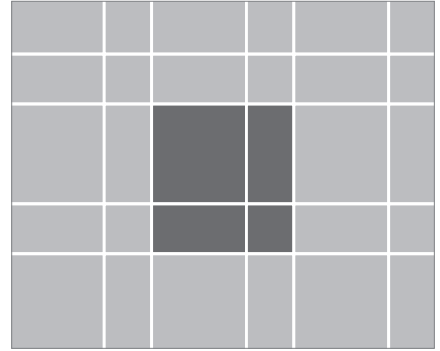

16,5x16,5 = 10,8%
16,5x33,3 = 44,2%
33,3x33,3 = 45%

16

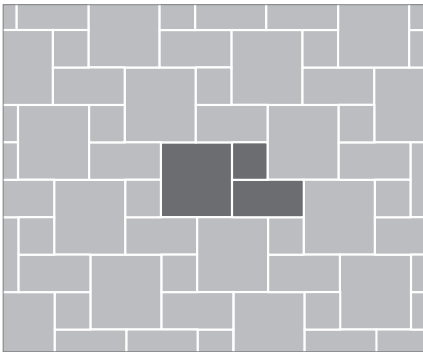

16,5x16,5 = 14,10%
16,5x33,3 = 28,45%
33,3x33,3 = 57,45%

17

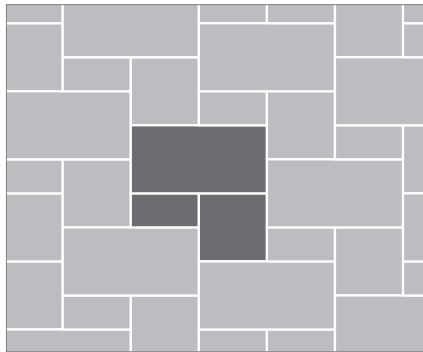

29,7x59,5 RETT. = 57,1%
29,7x29,7 RETT. = 28,6%
14,8x29,7 RETT. = 14,3%

18

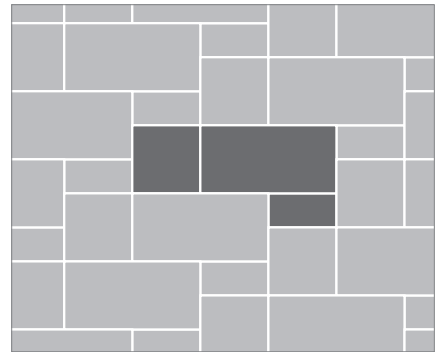

29,7x59,5 RETT. = 57,1%
29,7x29,7 RETT. = 28,6%
14,8x29,7 RETT. = 14,3%

19

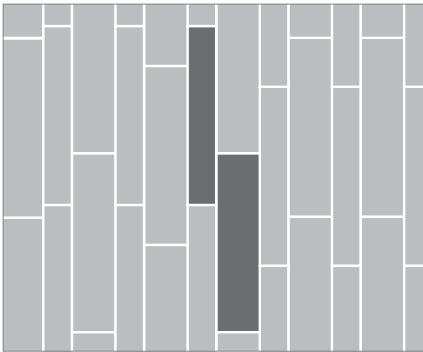

20x120 = 40%
30x120 = 60%

20

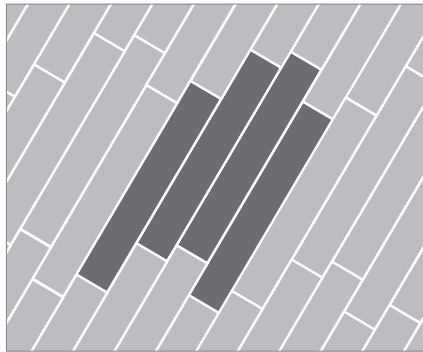

20x120 = 100%

21

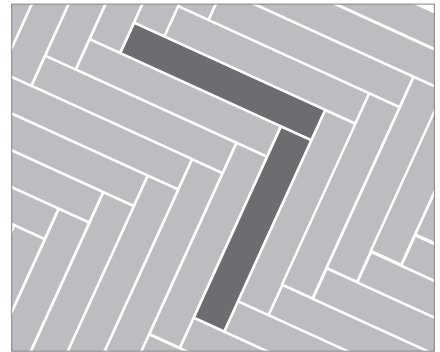

20x120 = 100%

22

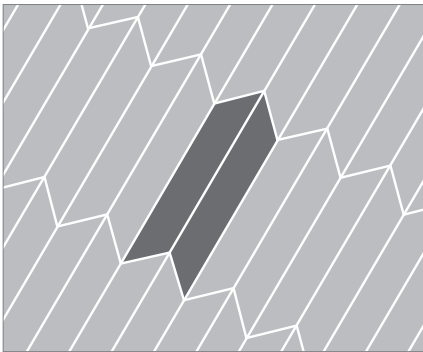

20x120 - CHEVRON DX-SX = 100%

23



20x120 CHEVRON DX-SX = 100%

24



20x120 = 12,2%
20x120 CHEVRON DX-SX = 87,8%

LA COSTANTE RICERCA TECNOLOGICA SI RISERVA DI APPORTARE SOLUZIONI ESTETICHE MIGLIORATIVE RISPETTO A QUANTO PROPOSTO NEL CATALOGO.

IN VIEW OF CONSTANT TECHNOLOGICAL RESEARCH, WE RESERVE THE RIGHT TO PROVIDE IMPROVED AESTHETIC SOLUTIONS COMPARED TO THOSE PROPOSED IN THE CATALOGUE.

LA RECHERCHE TECHNOLOGIQUE CONSTANTE SE RESERVE D'APPORTER DES AMELIORATIONS ESTHETIQUES PAR RAPPORT AUX SOLUTIONS PROPOSEES DANS LE CATALOGUE.

AUF GRUND DER STÄNDIGEN TECHNOLOGISCHEN FORSCHUNG BEHALTEN WIR UNS VOR, ÄSTHETISCHE VERBESSERUNGEN AN DEN IM KATALOG ANGEBOTENEN LÖSUNGEN VORZUNEHMEN.

В СВЯЗИ С ПОСТОЯННЫМИ ТЕХНОЛОГИЧЕСКИМИ ИССЛЕДОВАНИЯМИ ФИРМА ОСТАВЛЯЕТ ЗА СОБОЙ ПРАВО НА УСОВЕРШЕНСТВОВАНИЕ ЭСТЕТИЧЕСКИХ РЕШЕНИЙ, ПРЕДЛАГАЕМЫХ В КАТАЛОГЕ.

I COLORI RIPRODOTTI NEL PRESENTE CATALOGO SONO SOGGETTI ALLE TOLLERANZE PREVISTE DALLA STAMPA.

COLOURS SHOWED ON THIS CATALOGUE ARE SUBJECT TO TOLERANCES DUE TO PRINTING.

LES COLORIS REPRODUITS DANS CE CATALOGUE SONT SUJETS AUX TOLÉRANCES PRÉVUES POUR L'IMPRESSION.

DIE IN DIESEM KATALOG WIEDERGEgebenEN FARBEN SIND DEN FÜR DEN DRUCK VORGESEHENEN SCHWANKUNGEN UNTERWORFEN.

LOS COLORES REPRODUCIDOS EN ESTE CATÁLOGO SON SUJETOS A LAS TOLERANCIAS DE LA IMPRESIÓN.

Цвета, воспроизведенные в настоящем каталоге, имеют предусмотренные для печати допуски.



Ceramics of Italy



SAIME CERAMICHE

Via Giardini, 24

41042 Fiorano Modenese MO Italy

LAT: 44.5409960 (44° 32' 27.586")

LNG: 10.8615504 (10° 51' 41.581")

Tel. +39 0536 869611

Fax +39 0536 843823

+39 0536 830313

+39 0536 832533

+39 0536 869681

saime@riwal.it

www.saimeceramiche.com



Sede legale e amministrativa:

NUOVA RIWAL CERAMICHE s.r.l.

Via Ghiarola Nuova, 101

41042 Fiorano Modenese MO Italy

Tel. +39 0536 869411

Fax +39 0536 837321

info@riwal.it

www.riwal.it



Ceramics of Italy